

# The Wireless World

THE  
PRACTICAL RADIO  
JOURNAL  
23<sup>rd</sup> Year of Publication

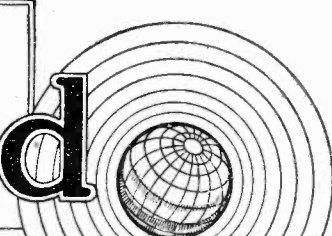
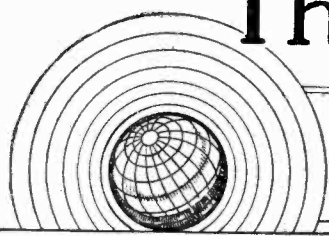

No. 740.

FRIDAY, NOVEMBER 3RD, 1933.

VOL. XXXIII. No. 18.

Proprietors: ILIFFE & SONS LTD.

Editor:  
HUGH S. POCKOCK.

Editorial,  
Advertising and Publishing Offices:  
DORSET HOUSE, STAMFORD STREET,  
LONDON, S.E.1.

Telephone: Hop 3333 (50 lines).  
Telegrams: "Ethaworld, Watloo, London."

COVENTRY: Hertford Street.

Telegrams: "Cyclist, Coventry." Telephone: 5210 Coventry.

BIRMINGHAM:

Guildhall Buildings, Navigation Street, 2.  
Telegrams: "Autopress, Birmingham." Telephone: 2970 Midland (3 lines).

MANCHESTER: 260, Deansgate, 3.

Telegrams: "Iliffe, Manchester." Telephone: Blackfriars 4412 (4 lines).

GLASGOW: 26B, Renfield Street, C.2.

Telegrams: "Iliffe, Glasgow." Telephone: Central 4857.

PUBLISHED WEEKLY. ENTERED AS SECOND CLASS MATTER AT NEW YORK, N.Y.

Subscription Rates:

Home, £1 1s. 8d.; Canada, £1 1s. 8d.; other countries abroad, £1 3s. 10d. per annum.

*As many of the circuits and apparatus described in these pages are covered by patents, readers are advised, before making use of them, to satisfy themselves that they would not be infringing patents.*

## CONTENTS

	Page
<i>Editorial Comment</i> .. ..	351
<i>Changing Over to Class "B"</i> ..	352
<i>Television Explained II.</i> ..	355
<i>The Cathode Ray Oscillograph</i> ..	356
<i>The Catkin in the Making</i> ..	358
<b>PROGRAMMES FROM</b>	
<i>ABROAD, pp. I—XXIV.</i>	
<i>Broadcast Brevities</i> .. ..	361
<i>How to Use Valve Load Diagrams</i>	362
<i>News of the Week</i> .. ..	364
<i>Sunbeam Midget Reviewed</i> ..	365
<i>Practical Hints and Tips</i> ..	366
<i>New Apparatus Reviewed</i> ..	367
<i>Readers' Problems</i> .. ..	368

## EDITORIAL COMMENT

### Tuning Scales

#### Importance of Clear Visibility

**T**HE broadcast receiver of to-day is a product of gradual evolution. The earliest sets were generally a collection of component parts wired together on a board. Gradually, for the sake of convenience and as a protection from dust, the components were accommodated in a box with the tuning controls accessible from the outside. In the early sets the principal control was a variable condenser with a scale to indicate tuning positions. Because there were, at the time, only some half a dozen stations to listen to, no great difficulty in tuning was experienced. By degrees improvements were made in the general arrangement of the controls; a reduction in the number of knobs and an increase in the compactness of the receiver being notable landmarks in progress; but the actual changes in the general form of a wireless receiver of to-day compared with that of ten years ago are not very great, although the circuit arrangements have, of course, undergone radical changes.

It is difficult to introduce originality where evolution in design is gradual, and this may be the reason why the tuning indicator has not, in our opinion, received the attention which it deserves. From the practical point of view, simplicity of tuning is one of the first requirements of a modern receiver, and yet nearly all the most modern receivers continue with arrangements for tuning and reading tuning positions almost as unpractical as were those of the earliest sets.

A clock is a good example of a piece of furniture designed for utility; the first thing required is that it should keep good time, and the second that you should be able to

see the time distinctly. Is not the same need just as great with a wireless set, where, assuming that the performance of the set is satisfactory, the next most important consideration is the ability to see clearly what stations you are tuning to without having to get down on your knees to examine a small section of the dial through an escutcheon plate, as is too often rendered necessary with present-day designs? Is there any good reason why the area of the tuning device should not be almost the maximum which the dimensions of the cabinet permit? There is room here for radical departure from the standard practice of to-day, and it would be a departure which we feel sure would be widely welcomed by the set user.

### Valve Booklet

#### A Guide to Modern Valves

**F**OR some years past it has been the practice of *The Wireless World* to issue during the autumn a special supplement giving technical data and general information on current receiving valves of all types. In this issue the information is again included as a special booklet, and in this form it will be found convenient for constant reference. Last year we decided to omit from our supplement information regarding valves of obsolete type, including four- and six-volt battery valves, and expressed the hope, which has since been fulfilled, that manufacturers would follow this example and discontinue listing obsolete valves in their catalogues.

The data in the booklet enables the user to choose his valves intelligently for every purpose, and the importance of having this information readily available cannot be too strongly stressed, particularly since the arrival of so many new and complicated types.

# Changing Over to Class "B"

## A Worth-while Modification for Battery Sets

**A**DDITIONS to existing receivers do not in practice always work as nicely as could be wished. But the substitution of a Class "B" output stage is an exception; by observing the precautions simply and clearly described in this article a receiver may be modernised without risk of failure.

**T**HOSE readers who feel happier about starting a job when they are in possession of definite constructional details are perhaps in difficulty about Class "B." Complete Class "B" designs have been presented in these pages; but for each reader who is interested in making an entirely new receiver there are no doubt quite a number who have battery sets that only need a Class "B" output stage to bring them more or less up to date, at a minimum cost. But, just as a sunshine roof intended to be fitted to an Austin Seven would fail to give satisfaction on a Daimler, so some hesitation may be felt in making use of constructional details intended to apply to an entirely different type of receiver. "How can my set be converted?" is the question.

The problem has not been made any easier by the appearance of a different type of Class "B" valve in the catalogue of each maker; and, as if that has not made things complicated enough, a variety of different methods are available for using each type of valve. A book of 100 pages would not be too much space in which to discuss all the points involved. People who have no time for that may find the accompanying table helpful.

### Sources of H.T. Supply

But first let us discuss power supply. Most of the valves listed can be used effectively on H.T. voltages between 100 and 150. At 100 volts they are hardly working to the best advantage, and cannot compete in output with mains-driven valves. At the other extreme, 150 volts is unnecessarily extravagant for the average home. So everything in the table

assumes 120 volts, thus greatly simplifying matters.

The ideal power supply for a Class "B" output is an accumulator battery, because of its steady voltage. But the greatest appeal of the system is to users of the humbler dry battery. There have been attempts to scare such people by pointing out that a peak current as high as 50 milliamps or even more may be taken from the battery, thus imposing a terrible strain on it. The same pessimists may quite probably be carrying a pocket torch, with which they do not scruple to extract 300 milliamps for periods of many seconds, from the smallest type of dry cell.

It may be granted, then, that 50 milliamps for a fraction of a second is not so disastrous as is sometimes made out. At the same time, of course, it still remains that a large-cell battery gives better service, other things being equal. But Class "B" does not rule out the ordinary standard size from all consideration.

Then there is the mains power unit. It is possible to produce units capable of running Class "B" stages. Whether there is any sense in doing so is another matter. The economy appeal is entirely lacking, because the unit must be designed to waste all the power that the Class "B" system saves. And, as there is some slight sacrifice in convenience and in quality of reproduction, as compared with a "straight" amplifier, it is rather difficult

to see what is the attraction. So our power is a plain ordinary 120-volt dry battery.

### Built-in Output Transformers

Then loud speakers; a moving-iron type can be used; but it is not really very nice. Now that permanent-magnet moving-coils are no longer luxury goods, one can almost assume them as standard even in economy systems. Most makers include transformers suitable for direct connection to any of the usual valves. You ask for one giving the load specified in column 5 of the table; and it must be a Class "B" transformer—one originally designed for push-pull is probably unsuitable because it counted on the core-saturating current being balanced out, which is not done in Class "B."

If you have a loud speaker already, with no suitable transformer, you must find out its working impedance.

Then you divide the figure in column 5 by it and take the square-root of the result, which gives the correct step-down ratio for the transformer. Example: impedance of loud speaker, 13 ohms; anode-to-anode load, 12,000 ohms; dividing one by the other gives about 900; square-root, 30. So the transformer, for accurate

matching, should have a 30 to 1 ratio.

Another transformer is required to couple the driver valve to the Class "B" valve. It is not wise to be too thrifty when getting these transformers. Much of the success of the system depends on using really first-class transformers, which are not found in the lowest price classes. Undue economy in the purchase department is likely to be rewarded by spurious oscillation and bad quality, and you will spend as much on extra components, trying

to make the best of a bad job, as you have saved on the transformers.

The correct ratio for this driver transformer is given in column 11, and refers to the whole secondary winding. Sometimes a 1 to 1 ratio is specified as 2 to 1 for the half-secondary, and one must be careful not to go wrong.

Of course, a Class "B" valve is

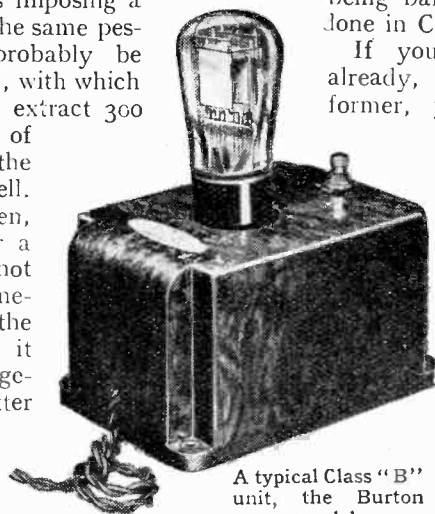

A typical Class "B" unit, the Burton model.

### CHARACTERISTICS OF WELL-KNOWN CLASS "B" VALVES.

Type.	Fila-ment Amps. (All 2-volt).	Grid Bias.	Qui-escient Anode Cur-rent. (mA.)	Anode-to-Anode Load.	Max. Undist. Output Watts.	Driver Valve.	Fil. Amps.	Grid Bias.	Anode Cur-rent. (mA.)	Driver Transr. Ratio.	Max. Signal Input to Driver R.M.S. Volts.	
Cossor	220B .. ..	0.2	Zero	2.5	12,000	1.2	215P	0.15	-10½	1.5	1 to 1	3.0
	240B .. ..	0.4	Zero	3.0	8,000	2.0	215P	0.15	- 9	2.5	1½ to 1	6.3
Ferranti	HP2 .. ..	0.4	Zero	3.0	8,000	2.0	Cossor 215P	0.15	- 9	2.5	1 to 1	6.3
Marconi and Osram.	B21 .. ..	0.2	-4½	1.65	12,000	0.9	L21	0.1	- 4½	1.7	1½ to 1	3.0
			-4½	1.65	8,000	1.4	LP2	0.2	- 6	2.5	1 to 1	4.0
Mazda	PD220 ..	0.2	Zero	2.0	17,000	1.0	L2	0.1	- 4½	1.5	2 to 1	2.65
			Zero	2.0	11,500	1.4	P220	0.2	- 6	2.5	1½ to 1	4.16
Mullard	PM2B ..	0.2	Zero	3.0	14,000	1.25	PM2DX	0.1	- 4½	1.5	1½ to 1	3.0



**Changing Over to Class "B"—**

needed, too. In selecting this several columns must be considered simultaneously. If you are content with about 1 watt maximum output the filament takes only 0.2 amp. instead of 0.4 for a 2 watt output, and a rather more economical driver valve will do. Another point is that in the B21 (and, optionally, to a less extent in the PD220) bias is used, thus departing from the pure simplicity of the original Class "B" idea. There are

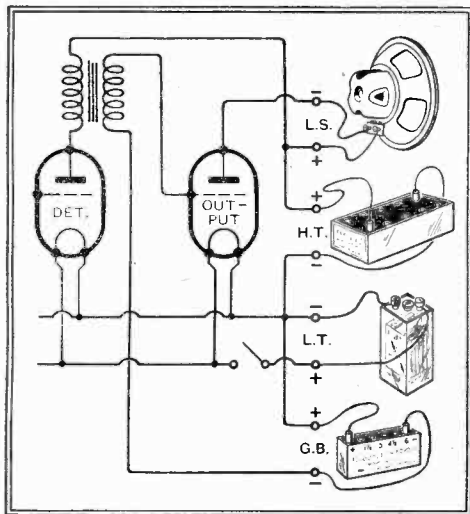

Fig. 1.—The L.F. section of a typical set, which is taken as an example in describing the necessary modifications.

several little complications about this bias—allowances for running-down batteries, and things of that sort. In return it is claimed that better economy and quality are obtainable—in particular that the original waveform of the desired programme is less likely to appear with decorations due to damped oscillation in the circuits. Tests show that this type of distortion is not inevitable in the zero bias system, if good components are used; but readers who are not frightened of complications (this article is addressed chiefly to those who are) should be able to get the best out of the system by judicious use of bias. The makers give full particulars about this.

**Original Valve as Driver**

Having decided on a valve to fit in with your ideas on economy versus power, the data relative to the driver valve can now be noted. There is no need to imagine that this is another valve to buy. Unless the present power valve has just expired, presumably one is all ready to hand. Actually a genuine power valve is rather preferable to the half-and-half types listed in column 7, which have been chosen to be as economical as possible consistent with giving the required output. There is no reason, for example, why a Mullard PM2A should not be used in place of the PM2DX; and it gives a bigger margin against distortion.

There is another reason for using a driver of reasonably low impedance. Although the table data assume 120 volts on that valve, too, a certain amount of

decoupling is much to be desired, though not always essential. That means a lower voltage on the driver—say, 90, and the higher impedance types of driver specified are then incapable of delivering the goods to specification.

The table figures can therefore be regarded as giving the most economical conditions; a valve of lower impedance, such as the power valve likely to be already in the last socket of the receiver, is even better, though perhaps not quite so thrifty. The bias should be increased till it takes only 2 or 3 milliamps—if no meter is available, plug into the largest bias which gives satisfactory reproduction. Incidentally, neither table nor makers' curves should be relied on implicitly for bias voltages. Valves vary. Actual trial, preferably measurement, must be made.

**Triode and Pentode Drivers**

The driver transformer ratio can go down a step or so if a substantially lower-impedance driver is used. Some examples of this are actually given. The Mazda L2, with 10,000 ohms, takes a 2 to 1 transformer. If the 3,700 ohm P220 is substituted the best ratio becomes 1½ to 1. It is not very difficult to judge a reasonably correct ratio by working on these lines.

It is possible to use a pentode driver. Try it, if you happen to have a pentode and no suitable triode. The transformer ratio may be taken as that applying to a valve of about 12,000 ohms. It may need a little careful doctoring to prevent the quality of reproduction from being altogether too shrill and "edgy." The Class

enough "signal" input. If a valve is used of lower amplification factor than that given in column 7, the signal voltage has to go up in inverse proportion.

And, having now chosen the valves and other components, that brings us to the actual circuit alterations to be made to the present set. Remember that what was the output valve is now the driver, and the Class "B" valve is an extra. The type of circuit in which the driver is re-

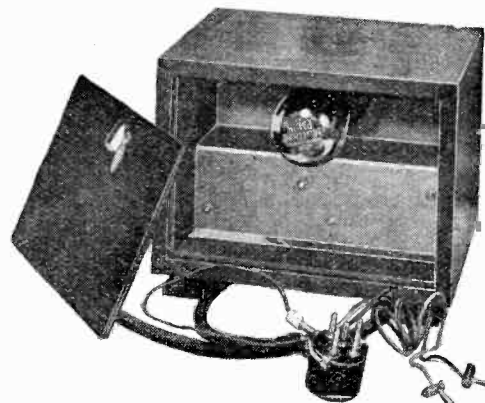

The Multitone Class "B" unit for adding to an existing set.

sistance-coupled from the detector, though admirable theoretically, is not likely to be found, because the detector would almost certainly be working beyond its ability, with only 120 volts available for everything. A transformer coupling, with the usual ratio of 1 to 3 and upwards, is perhaps the soundest source of the signal volts in column 12. Many sets have an L.F. valve between detector and power valve. If at least one of these is resistance-

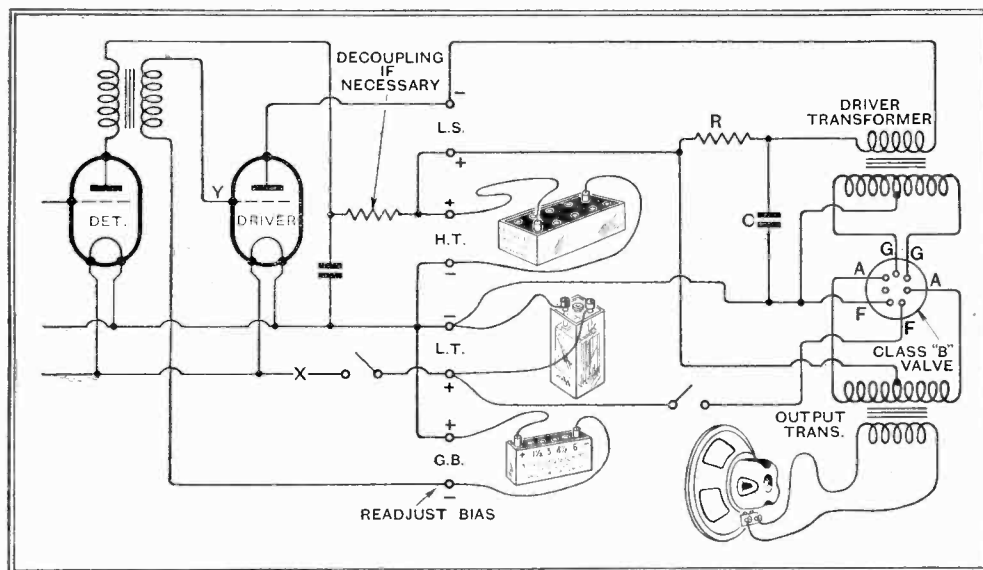

Fig. 2.—A semi-practical wiring plan, showing how to connect the Class "B" valve and components.

"B" valve, it must be remembered, is equivalent to a pentode in this respect; and two in series are inclined to make this feature rather too pronounced. A tone-control transformer (e.g., the Multitone) is particularly valuable in these circumstances.

The last column is meant to give guidance in deciding what must be used in front of the driver valve to give a strong

coupled, it may be passed for use—keeping an eye on extra decoupling if it proves to be needed—but two transformer-coupled stages is not a very promising situation. It is usually unpleasant enough in its original form, and the extra Class "B" stage holds a magnifying glass to its defects. Either cut out a stage entirely, or substitute resistance-coupling in one of them.

**Changing Over to Class "B"—**

Now for the actual conversion. Fig. 1 shows the hinder parts of a typical battery-driven receiver. Fig. 2 shows the same with Class "B" extensions and alterations. If the last valve but one in Fig. 1 is already decoupled it may be possible to get away without any internal alterations whatsoever, only the grid bias being adjusted to economise in H.T. current. But if no decoupling was used it is most desirable to fit it now; perhaps the previous H.T. voltage was only 100, which means a useful margin of 20 to play with. The resistance may be 10,000 ohms, or 20,000 if an increase has been made in H.T., and the condenser as large as possible, but not less than 2 mfd.

Only four leads need be attached to the Class "B" annex. If the existing L.T. switch is to command the whole apparatus, obviously the positive L.T. lead to the Class "B" valve must be taken to the point X instead of as shown; the second switch is then superfluous. Not all sets are switched exactly so; where there are divergencies from this simple practice it is important to go warily to avoid short-circuiting batteries or blowing valve filaments.

The Class "B" valve-holder connections are shown in worm's-eye view, i.e., as seen from the underneath. Driver de-

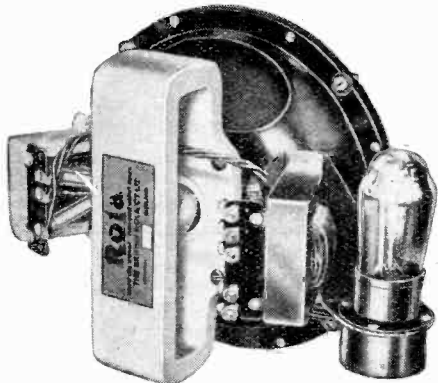

Class "B" output stage built on to a loud speaker.

coupling is included—R and C. As already explained, this cannot be allowed with high-impedance economical driver valves, and is not always needful in any case. But if the regular power valve is used it is just as well to include them, as specified for the previous valve. The grid bias may then perhaps be right without any increase. Clearly there is no change in principle if a combined H.T. and bias battery is used. It just means one terminal fewer.

The Class "B" circuit of Fig. 2, apart from the decouplers, is the simplest possible. It is almost certain to be too simple to be satisfactory. First, the tone will probably be too high-pitched. One way of modifying this is to connect a resistance of about 10,000 ohms, in series with a condenser of about 0.01 mfd., across the whole primary of the output transformer, just as for a pentode. This also serves as a safety valve if the loud speaker happens to be disconnected when the valve is working. But, purely as a tone control, it may

perhaps be bettered. There is not much point in carefully amplifying an excess of high tones, at cost of valuable H.T., and then just throwing it away. If the tone is controlled somewhere previously, as can be done by using a tone-control driver or intervalve transformer, there is appreciable extra economy.

If the output transformer can be worked absolutely "bare," as shown, so much the better; there is a minimum of distortion such as is introduced by artificially reducing the load by a tone corrector. But sometimes it is found necessary to resort to various dodges to prevent divers sorts of oscillation. The symptoms are harsh reproduction and unduly large standing anode current. If good transformers and

well-spaced wiring are adopted there should be no trouble of this sort. The usual cures are condensers and/or resistors shunted across the halves of driver and output transformers. The values depend so much on conditions and components that it is really hard to generalise, and the valve makers kindly supply hints with the valves.

If there is any tendency to upset things in the H.F. circuits, the probable cause is inadequate filtering of the detector output. A useful way of helping to keep H.F. current away from the L.F. end is to insert a resistor of about 0.1 megohm in the lead to the grid of one or both L.F. valves (but *not* the Class "B" valve) at the point Y in Fig. 2.

## DISTANT RECEPTION NOTES

### Heterodyne Peculiarities: Daylight Concerts from Abroad

**M**YSTERY surrounds the station which is causing so much trouble with Huizen. Though the authorities of the Dutch station themselves state that the interloper is the Roumanian station Brasov, I see that in the latest U.I.R. report it is called a Soviet transmitter.

Heterodynes are surprising things. One might, for instance, expect that Huizen would be bothered by both the 7-kilowatt Kaunas, 5 kilocycles below, and the 40-kilowatt Lahti, 7 kilocycles above. Both of these stations are in regular operation, as the U.I.R. report shows, but it is very seldom that even the ghost of a whistle due to them is heard.

### The "Record" in Whistles

Then Oslo. The 10-kilowatt Tiflis is working just now barely 4 kilocycles above the Norwegian station, whilst the 35-kilowatt Minsk is but 6 kilocycles below it. Yet, except on rare occasions, Oslo is not now heterodyned. Against these may be set last year's "record" heterodyne, when a Siberian station heterodyned Kalundborg nearly 3,000 miles away.

Good as it is now, transatlantic reception should be vastly better before the winter is over, for numerous American stations are bringing their power up to 50 kilowatts. This is the highest output rating allowed in the United States, and at present the number of transmitters using it at any one time is only nineteen. There are more 50-kilowatt stations than this, but several of them work in pairs on the same wavelength, one being silent whilst the other is transmitting. When the new scheme is complete there will be more than thirty 50-kilowatt stations in simultaneous operation.

The only exception to the 50-kilowatt rule in WLW, Cincinnati, which is being allowed to erect a 500-kilowatt station. I hear from America that tests are to begin shortly. The results will be closely followed by the Federal Radio Commission, which will make the final decision.

With its present 60 kilowatts, Bero-münster is often an extraordinarily good daylight transmission in this country. It is shortly to go up to at least 100 kilowatts. When the new plant is in operation this country should be to all intents and purposes within its service area. The power of Söttens is to be increased also from 25 to 75 kilowatts.

It is reported that the French Government intends to compel both Toulouse Midi and Fécamp to close down. Seeing that Fécamp is now officially radiating 700 watts I imagine that it will still come through fairly well even when "completely closed down!" The French Government's dealings with its broadcasting stations always remind me of the description of the alleged trained dog: "One word from his master and he does . . . exactly what he likes!"

Atmospherics are now mercifully absent and long-distance reception may be pursued under almost ideal conditions. There is a certain amount of heterodyning on both wavebands, but the choice of stations is none the less a large one. Those best worth attention on the long waveband are Radio-Paris, Zeesen, Warsaw and Oslo. On the medium waves Budapest, Prague, Langenberg, Rome, Leipzig, Strasbourg, Breslau, Hilversum, Heilsberg and Nürnberg are outstanding. D. EXER.

## A ROYAL RECORD



H.R.H. Prince George pressing a record of the Prince of Wales' voice during a recent visit to the H.M.V. factories at Hayes. The royal guest spent several hours in studying all the processes of radiogramophone and record manufacture.



# Television Explained

## II.—The Transmitter and Receiver

**I**N Part I of this series it was shown how the picture to be televised is converted into a series of strips and the light variations along these made to produce a varying current in a photo-cell. Although this current is strictly speaking uni-directional, it may be considered as being an alternating current superimposed upon a steady direct current, just as we make the same assumption in the case of the anode current of any valve. The photo-cell output, therefore, can be considered as an alternating current, which is strictly analogous to the current output of a microphone used in sound transmission.

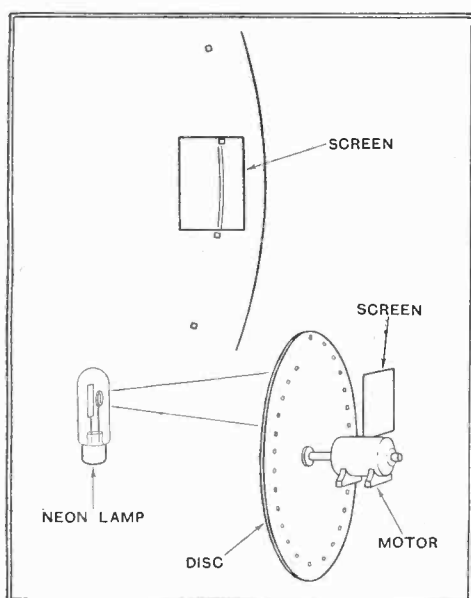

The upper portion of this drawing shows the manner in which the holes in the scanning disc pass over the viewing screen, while the lower portion illustrates the arrangement of the apparatus. The light from the neon tube passes through the holes in the disc and falls on the screen. The position of the spot of light at any instant is determined by the precise position of the disc.

The photo-cell output can thus be treated in exactly the same way as the output of a microphone; it is amplified to the requisite degree, and then used to modulate the carrier of the transmitter. Such differences as may occur in practice are due merely to the different frequencies involved in television as compared with sound broadcasting. Instead of the range of modulation frequencies being from 30 cycles to 10,000 cycles, in the case of television it may be from  $12\frac{1}{2}$  cycles to 300,000 cycles or more, depending upon the precise details of the television equipment.

In the receiver there is again no difference, apart from the different range of modulation frequencies involved. H.F. amplification, detection, and L.F. amplification are all necessary and follow stan-

dard practice. In fact, the equipment necessary for television is fundamentally the same as that used for sound broadcasting, save that at the transmitter suitable optical apparatus and the photo-cell replace the microphone, and at the receiver a light source and optical apparatus replace the loud speaker. For the present, therefore, we need not consider the electrical circuits of transmitter and receiver, and we can turn directly to the television "loud speaker."

Primarily, this consists of a light source of such nature that the light intensity is proportional to the operating current, and which is capable of responding instantaneously to rapid variations in the current. This last requirement rules out all ordinary lamps, and it is usual to employ a neon tube, although other and more efficient methods have been developed. The lamp is commonly connected in the anode circuit of the output valve of the receiver, and the steady anode current passes through it. In the absence of a signal, therefore, the lamp gives out a steady light the intensity of which depends upon the value of the anode current, and which can be controlled by varying the anode current.

### The Scanning Disc

The television signal causes fluctuations in this steady current, and the light then varies in sympathy. If we look directly at the lamp, therefore, we can see all the light variations of the transmitted picture, but they do not form any intelligible picture because the picture has been broken up into a series of strips at the transmitter, and it is necessary to reassemble these at the receiver.

This is carried out by means of a Nipkow disc, the whole process being exactly the reverse of that at the transmitter. The disc is interposed between the viewing screen and the neon tube, as shown in Fig. 1, and matters are arranged so that the light from the tube can fall upon the screen through only one hole at a time. The disc must be identical with that used at the transmitter, and it must rotate at exactly the same speed; furthermore, at the instant when any one hole is just commencing to scan the picture, the corresponding hole at the transmitter must also be just commencing to scan the picture. In this way the strips into which the picture was broken at the transmitter are reconstituted in their correct relative positions at the receiver, and the picture can be seen on the screen.

It will be seen that the difficulties involved are two—the attainment of exact synchronisation of the discs, and obtaining sufficient illumination. Taking the latter

*THIS is the second of a series of articles intended to outline the general principles of Television and proceeding, in later instalments, to an explanation of the various individual systems now being developed.*

first: in a cinema, if there are ten pictures a second, each picture is fully illuminated for rather less than one-tenth of a second. The televised picture, however, for the same picture frequency, requires a much stronger light source for the same illumination, for at any instant there is only one small spot of light on the screen. This will be seen from Fig. 2, which illustrates the traverse of the light spot at the receiver. This small spot covers the whole picture in one-tenth of a second, and consequently it must be of extraordinary brilliance if the whole picture is to appear in any detail.

A concrete example may serve to emphasise the importance of this point. Assuming for simplicity that there are ten pictures a second in a cinema, each picture is completely illuminated for a twentieth of a second, if the interval between successive pictures is equal to the duration of each picture. With television equipment there is no interval, but the area of the light spot is only about  $1/2,000$  of the picture area, so that any given portion is illuminated for only  $1/20,000$  of a second. The increase in illumination required, therefore, will be readily apparent.

It is on the score of brilliance that the neon tube is apt to fail as a light source in a television receiver, but nevertheless it is possible to obtain quite good results with it, although there are now better methods available. The chief difficulty lies in synchronising, for the degree of accuracy required is so high as to neces-

At any instant the picture consists of no more than a single minute spot of light, but, owing to the retentivity of the eye, the movements of this cannot be distinguished, and the effect of a steady picture is obtained.

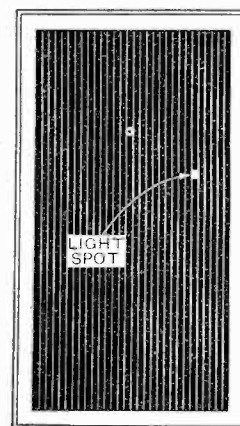

sitate a definite linking of the transmitter and receiver. Synchronising is really a whole subject in itself, and it will be dealt with briefly in the next article of this series.

# The Cathode-ray Oscillograph

## What It Is and How It Works

By A. L. M. SOWERBY, M.Sc.

WHEN receiving an ordinary wireless signal the valves in the receiver have to deal with currents that may change their direction several million times in a second. Between each reversal of direction and the next, there is a continual variation in the intensity of the current, and the valve is called upon, if it is to amplify without distortion, to follow even this finer detail of an immensely rapid phenomenon.

The current is carried through the valve by electrons, which are particles of more or less material type flying, under the influence of the various voltages applied to the electrodes, through the evacuated space. The inconceivable rapidity of their response to the fluctuations of the voltages applied is a graphic demonstration of their extreme smallness and almost complete lack of inertia.

In the valve, although the flying electrons respond to the fluctuations of voltage on the grid, there is no satisfactory means of observing this response. The only way in which the variations of current can be made visible is by connecting a milliammeter in series with the valve, and though the milliammeter will indicate faithfully enough any *slow* changes in current, the mechanical inertia of its

*THE cathode-ray oscillograph is becoming more and more important in its applications to investigating what happens in wireless circuits, and particularly in indicating wave form and distortion. One of the most important applications of the cathode ray tube is, however, its use in television systems. The purpose of the present article is to give the reader a clear idea of the principle of operation of the tube, in order to pave the way for a better understanding of television circuits where the tube is employed.*

that their movements, no matter how rapid they may be, can be followed by the eye. Though the electrons are far too small to be seen, individually or in groups, the energy they carry, especially when travelling really fast, is fairly considerable. A thin beam of electrons, arriving at a point with a velocity acquired by being made to pass through a thousand-volt field, carries power equivalent in magnitude to that dissipated by a glow-worm or other faint but readily visible light-source.

### Conversion into Light

The problem of converting the electro-mechanical energy of the flying electrons into light, in order that their energy may be directly appreciated by the senses, is solved by the fluorescent screen. This consists of a thin layer of suitably prepared calcium tungstate or zinc silicate coated upon glass or other support. When a beam of high-velocity electrons strikes such a screen, the electrons are

stopped and the energy of the flight is largely converted into light. The arrival of the electrons is thus made visible by the appearance of a glow upon the screen, the size and shape of the glow corresponding to the area upon which the electrons are impinging.

In a valve, variations in the voltages applied to the control-electrode (the grid) are represented in the anode circuit by variations in current—that is, by variations in the number of electrons arriving at the anode in each second. Such variations, if made visible with the aid of a fluorescent screen, would show up as fluctuations in brilliance of the patch of light—a type of change to which the eye is extremely insensitive. The construction of an electron-tube designed to enable

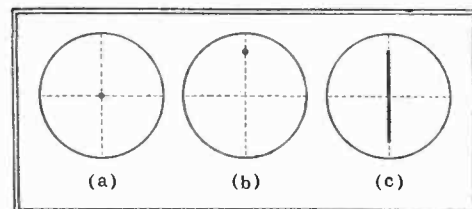

Fig. 2.—Appearance of the screen of the tube of Fig. 1. (a) When no voltage is applied to the deflector plates. (b) When a steady voltage is applied to the deflector plates. (c) When an alternating voltage is applied to the deflector plates.

rapidly varying voltages to be studied by visual examination must, therefore, be different from that of a valve, the design being directed towards *deflecting* the electrons in their flight in a manner depending upon the voltage instead of varying the number of them passing through the tube. By this means the changes in the voltage to be studied are seen as movements of a point of light across the fluorescent screen.

How this end is achieved will best be seen by studying the electrode-arrangement of a cathode-ray oscillograph. Fig. 1 shows the essentials of a simple tube in diagrammatic form. The filament F, on which there is at E a single spot of emitting material, is heated by a battery, with the result that electrons are emitted from E. From this point they would fan out in all directions, as light is radiated from a single bright point, were it not for the fact that a high positive voltage

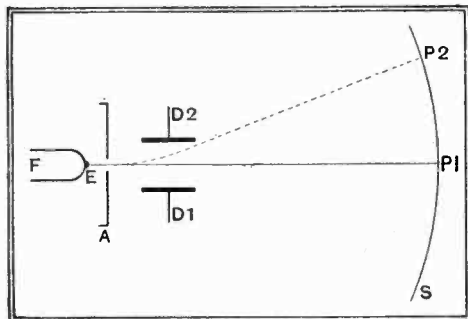
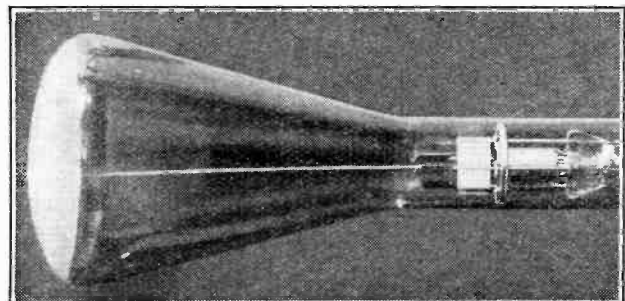

Fig. 1.—Electrodes and screen of a crude oscillograph tube, illustrating the principles of operation.

moving parts (coil, pointer, and so forth) make it quite impossible for it to follow changes in currents which are varying at any really high speed. By choosing a mechanical indicating instrument we lose, in fact, all the advantages that the instant response of the electrons seemed to offer.

The cathode-ray oscillograph is, in essence, a type of valve in which the electrons are themselves made visible, so



Two actual photographs showing the projected beam of electrons. The beam in its normal position is shown on the left, whilst the effect of deflecting the beam is represented on the right.

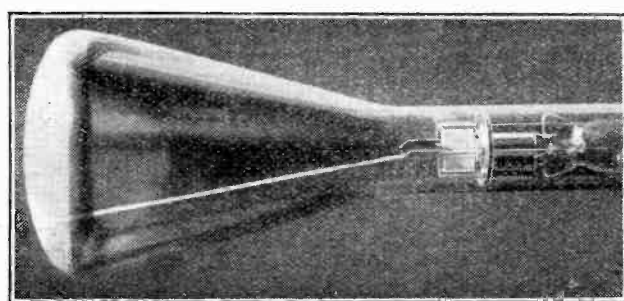



**The Cathode-ray Oscillograph—**

is applied to the anode A. This consists of a sheet of metal pierced with a small pinhole opposite the emitting point E. The electrons from E are drawn violently to A by its high positive voltage, arriving

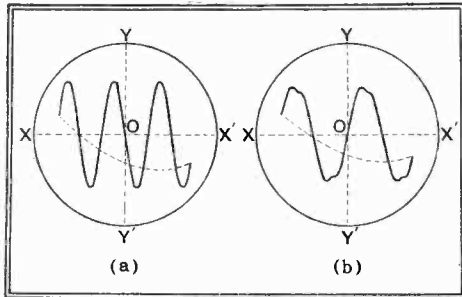

Fig. 3.—(a) The trace of an oscillograph screen produced by combining an alternating voltage (vertical scale) with a linear horizontal traverse (time-base). (b) The same, for an alternating voltage of bad wave form.

upon it at very high speed. A certain number fly through the pinhole at this high velocity, and, passing between the two deflector plates  $D_1$  and  $D_2$ , arrive eventually at  $P_1$  on the fluorescent screen S, where a visible spot of light appears.

If  $D_1$  and  $D_2$  are held at the same potential as the anode A, the beam of electrons suffers in passing between them neither a change in velocity nor any deviation from its original path. But if  $D_1$  is made more negative than the anode,  $D_2$  remaining at anode potential,  $D_2$  will attract the electrons more during their flight than will  $D_1$ , with the result that they will take a path such as that shown in dotted line, and will arrive eventually at the point  $P_2$  on the screen. In addition, since the mean potential of  $D_1$  and  $D_2$  is now lower than when they were both connected to A, the velocity of the electrons comprising the beam will have dropped a little, which will increase the distance  $P_1P_2$ , since a more slowly travelling electron is naturally more readily deflected. This means that if a succession of voltages are applied to  $D_1$ , the resulting deflections of the spot of light will not be exactly proportional to the voltages, each additional volt having a little more effect than the last. By splitting the deflecting voltage, making  $D_2$  positive while  $D_1$  is made negative, the mean potential of the two can be kept the same as that of the anode; the same change of voltage will then result in the same deflection at all points on the screen.

Instead of a steady voltage we may apply an alternating voltage between the deflector plates. The spot of light on the screen will then fly backwards and forwards at the frequency of the voltage applied, tracing out a line on the screen. This line, centring on  $P_1$ , will indicate by

its length the magnitude of the voltage, but persistence of vision, together with some "afterglow" from the screen, will prevent the eye from following the rapid to-and-fro movement of the spot.

The appearance of the screen resulting from the application to the deflector-plates of zero voltage, a steady voltage, and an alternating voltage can be seen from Fig. 2.

**The Time Base**

If a cathode-ray tube is to be of any real service in studying an alternating voltage the line of Fig. 2c must be developed into some more informative figure. This line is produced by the rhythmic up-and-down movement of the spot of light, which follows faithfully at every instant the voltage applied to the deflector plates. Let us suppose that the spot of light is given a horizontal movement independent of the vertical movement we are trying to study, and let us further suppose that this horizontal movement consists of a single trip across the screen at constant velocity from left to right. The up-and-down movement still continues, but the added left-to-right movement means that as the spot moves upwards the path it traces out is no longer vertical, but is slanted over to the right, the slant increasing as the spot slows towards the end of its travel. At the moment when the upward movement has ceased and the downward movement is about to begin the travel is purely horizontal, while as it comes downwards the path is again deflected towards the right. The whole pattern traced out will be seen by an observer in a form something like that shown in Fig. 3a.

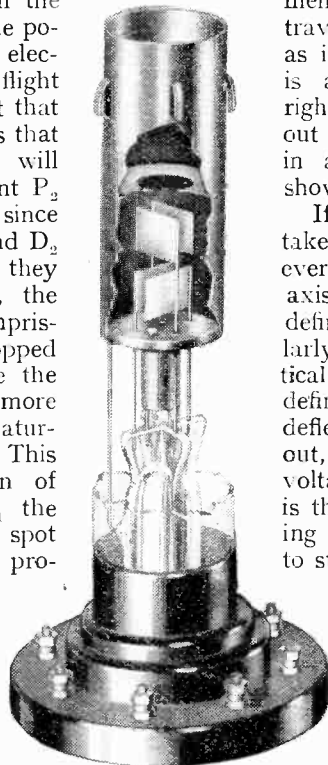

Fig. 4.—Internal construction of Coscor cathode-ray oscillograph. Bulb and fluorescent screen not shown.

If the left-to-right movement takes place at constant velocity every inch along the horizontal axis XOX' represents some definite period of time. Similarly, every inch along the vertical axis YOY' represents some definite voltages applied to the deflector-plates; the curve traced out, therefore, is a graph of this voltage plotted against time. It is the waveform of the alternating voltage we have been trying to study. In Fig. 3a a more or less conventional "sine-wave" is shown, but we may find that the voltage in which we are interested contains components of several different frequencies, in which case some "distorted" wave, such as the remarkably bad specimen exhibited in Fig. 3b, may make its appearance on the screen. The distortion may be then traced to its source and eliminated, if such is the purpose for which the alternating voltage is being examined.

The second sweep of the electron-beam, that from left to right, requires a second pair of deflector-plates set at right-angles to the single pair indicated in Fig. 1. The photograph of Fig. 4 shows the electrode

assembly of an actual cathode-ray tube, and shows very clearly the two pairs of deflector-plates one above the other. Immediately below them is the anode, the central hole in which is clearly visible. Round the filament is a cylindrical electrode, usually known as the shield, to which in practice a negative potential is applied. The effect of this, combined with a small amount of an inert gas within the tube, is to assist in focusing the electron beam so as to give a small spot rather than an ill-defined bright patch on the screen, and hence to provide figures traced out by a thin, clear line. A further effect of the shield is to increase the number of electrons passing through the anode hole.

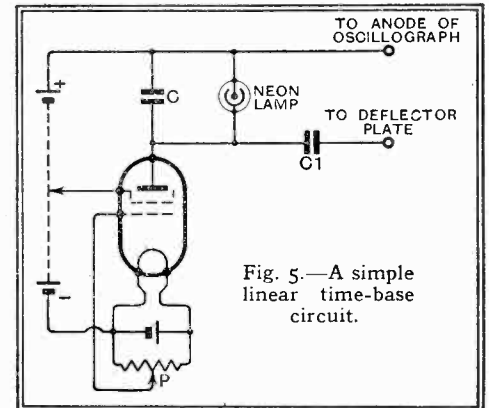
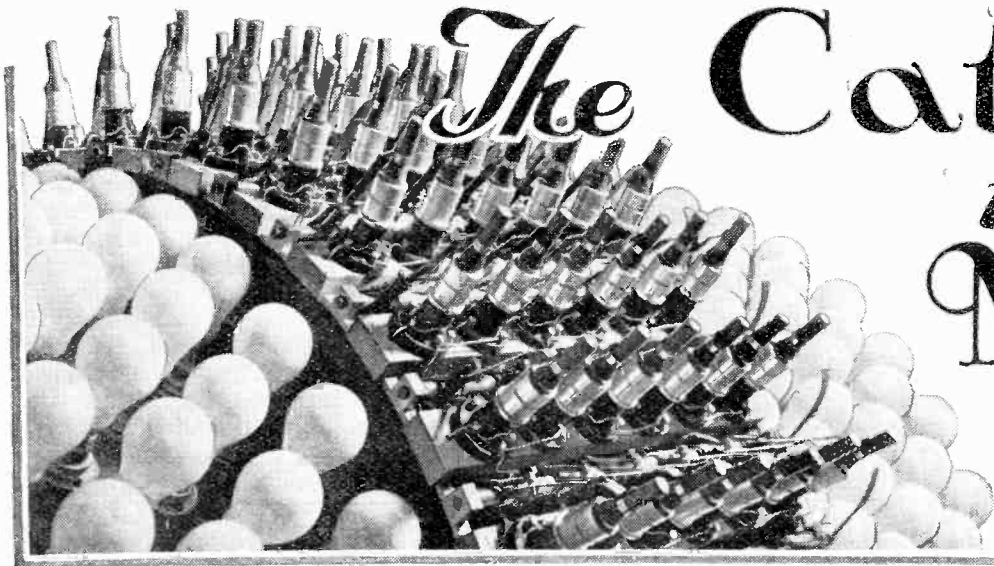

Fig. 5.—A simple linear time-base circuit.

For providing the voltage applied to the second pair of deflector-plates to give the left-to-right sweep of the beam a "time-base circuit" is required. In one of its simplest forms this may consist of a condenser C shunted by a neon lamp (Fig. 5), together with means for charging the condenser from a steady current source. When the voltage across C, receiving a charge from the battery, rises to the striking voltage of the neon lamp the latter lights, thereby drawing a current which discharges C to the voltage at which the lamp will no longer stay alight. Recharge to the striking voltage then begins again, and so the process continues, the voltage on C showing in continuous succession a slow rise followed by a sudden drop. The slow rise is used to carry the spot from left to right across the screen, while the sudden drop sends it back at high velocity to begin its traverse over again.

The current through the screen-grid valve used as constant-current device may be controlled by adjustment of the grid-bias potentiometer P; this, in conjunction with the choice of screen voltage, allows the rate at which occurs the charge and discharge of the condenser to be controlled. By making this process take, say, three times the period of a single cycle of the alternating voltage under examination, three complete waves of this voltage appear on the screen. But it will be appreciated that it will only be when the three-to-one ratio is absolutely exact that successive repetitions of the picture will occupy exactly the same place on the screen; a slight variation from the intended ratio will cause the waves seen to progress steadily across the screen as each successive figure makes its appearance a shade to right or left of the last.





A bank of Osram "Catkin" valves minus their metal shells.

## True-to-type Valves by New Methods in Hammersmith Factory

**W**HEN the Catkin valve made its sudden appearance in May last, and showed at a glance that there *could* be something new under the sun, it fully warranted the eager interest aroused on all sides. There had been achieved a radical departure from orthodox methods of manufacture; the M.O. Valve Co., producers of the new valve, had abandoned the traditional lamp form of construction and had struck out with a design which was not only original but sound.

Strangely new designs involve strangely new methods of manufacture, and it is with such methods that this article concerns itself. A visit to the Hammersmith works where Osram (Catkin) valves are made reveals a new world to the man familiar with the valve-manufacturing methods of the last fifteen years.

The essential differences between the Catkin and the glass valve will bear repetition. They are as follows:—

(1) The abolition of a glass "pinch" and its substitution by a mica insulated steel clamp.

(2) The abolition of bent and welded wires in the electrode support system and substitution of strong, straight supports which are rigidly held in the steel clamp.

(3) The use of a new form of circular

seal, round the circumference of which the leading in wires are spaced.

(4) The possibility of eliminating the glass bulb and substituting an air-cooled anode forming the exterior envelope of the valve. (This principle has been adopted for many years with success on large transmitting valves dissipating the equivalent of many kilowatts in heat.)

(5) The abolition of capping paste

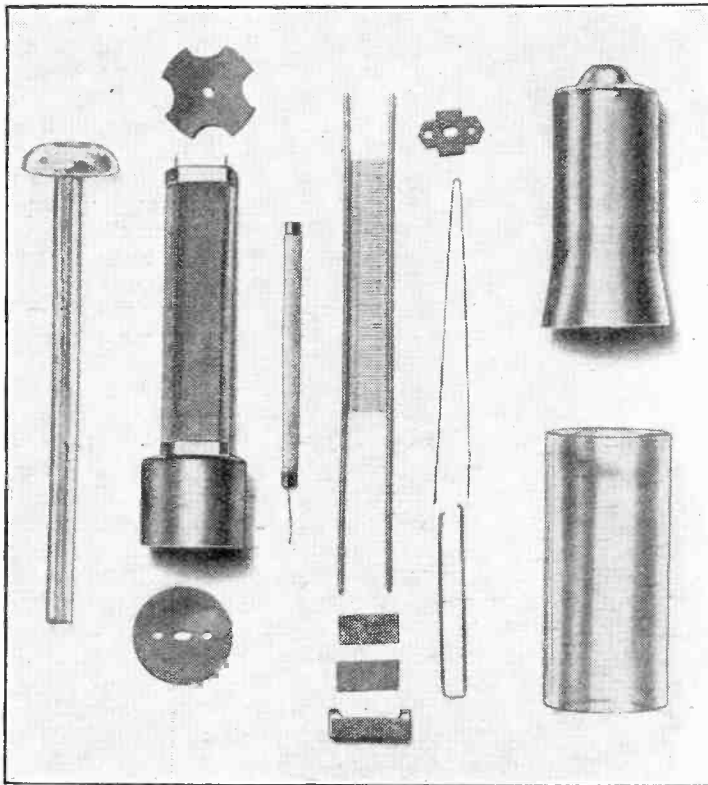

A complete set of components for an A.C. screen-grid "Catkin." On the right is an unshielded specimen with a metal shield ready for fitting.

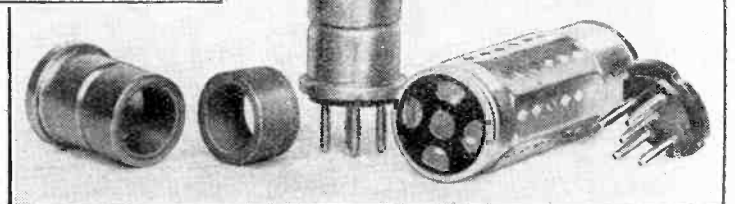

# The Catkin in the Making

*THE metallised valve has wrought a revolution in factory methods, as can be judged from this description of the fascinating new processes involved in making Osram "Catkin" valves. The illustrations show how the advent of the metal valve has facilitated the use of mass-production methods.*

and substitution of a rubber ring in a metal shell.

(6) The substitution of a ventilated metal outer container in place of the metallised bulb.

Let us see how these various processes are carried out. The accompanying illustration shows the complete set of components for the A.C. screen-grid valve. The mixture of strontium and barium oxide normally used as an electron-emitting material coated on the nickel-plated cathode in indirectly heated valves is improved upon in the Catkin. The cathode can thus be run at a lower temperature, allowing the use of larger inter-electrode clearances and leading to greater uniformity. An illustration opposite shows the cathodes being sprayed. The cathode is supported axially in the control grid by two mica insulators, the central holes of which locate the cathode, while the grid wires pass through other holes. The control grid, similar to that used in glass valves, is welded to straight support wires which, after passing through the holes in the mica, are slightly flattened to retain the mica in position.

Now comes the insertion of the tungsten heater inside the cathode. The heater is welded to support wires, this and the weld to the cathode lead being the only welds in the electrode support system. A



**The Catkin in the Making.—**

specially prepared steel and mica clamp is now pressed around the electrode assembly. This finished clamp is shown in the photograph below. Copper-clad nickel-steel wires are welded to the electrode supports below this clamp, and we now have a complete electrode assembly for an MH4 triode valve, the unit being ready for insertion into the copper anode.

The construction does not vary very much in the case of different types. With the screen-grid valves VMS4 and MS4B the top mica fits inside the top of the screen while the bottom mica fits inside and abuts against the shoulder of the extended cylindrical skirt, thus rigidly determining the position of the grid cathode assembly within the screen. The screen itself is hexagonal, and has solid sides to give the minimum grid-anode capacity. Another mica insulator is now attached to the top of the screen and the completed assembly passes within

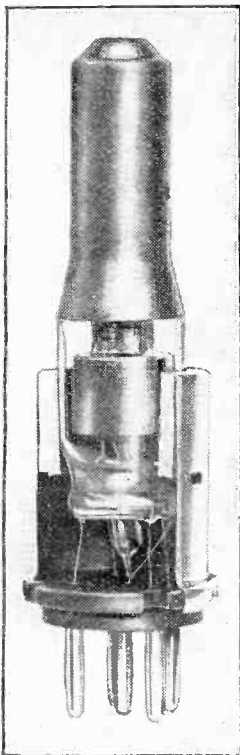

Sectional photograph showing the rubber ring method of capping. The right-hand picture shows the control grid, cathode and heater assembly with steel-mica clamp.

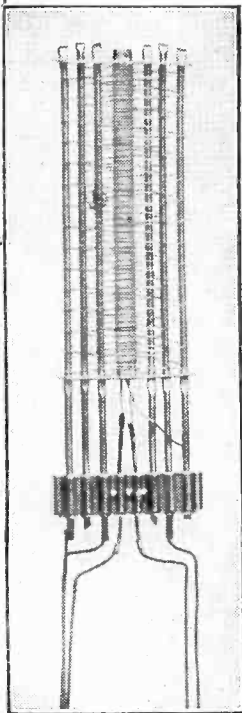

the copper anode with its glass foot tube.

Whatever the particular type of valve this method of construction obviously ensures great accuracy in the registration of the various electrodes.

The copper anodes of Catkin valves are solid drawn from copper sheet, and the dimensions can thus be maintained within much closer limits than by the usual method of stamping and welding blanks on thin material. A large factor of safety at working temperatures is secured by reason of the fact that the copper is of sufficient thickness to withstand atmo-

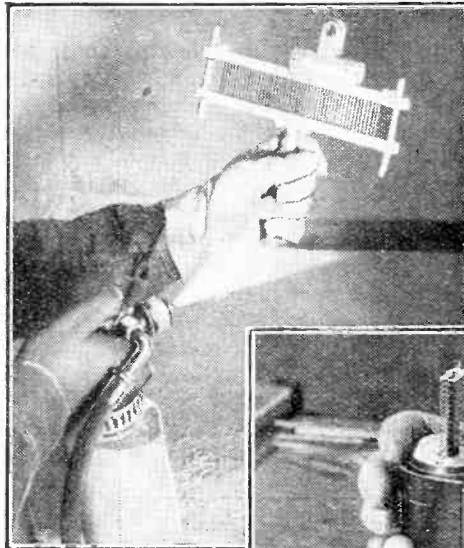

Above: How the cathodes are sprayed in Osram "Catkin" A.C. valves. Right: One of the jigs used to ensure accuracy of spacing in assembling the electrodes.

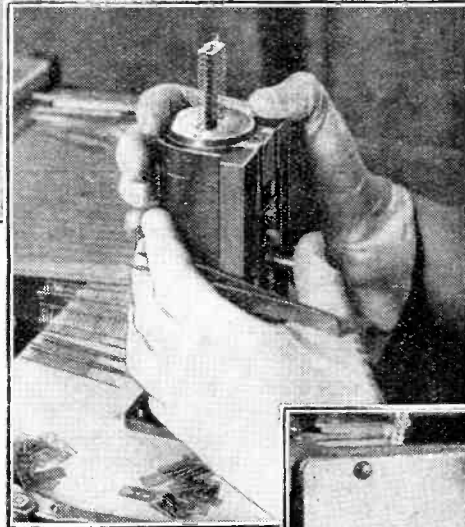

spheric pressure at the high temperatures used in the exhausting processes.

The only glass used in a Catkin valve is the glass foot tube employed to provide the necessary insulation at the lead-in wires.

In joining the glass to the copper anode the open end of the anode is slightly flared and the edge tapered where it is joined to the glass; this thin edge and the end of the glass tube are made red hot in a gas flame and then brought together. In this way a join is formed which, after suitable annealing in a special electrical oven, is both vacuum tight and very strong. In spite of the differences in expansion of the glass and the copper, this join will stand large changes in temperature owing to the ductility of the thin copper flange. The electrode assembly is now inserted into the anode, and the open end of the glass tube is closed by sealing into it a specially shaped exhaust tube not unlike a mushroom. Such tubes are shown in the accompanying photograph.

**Pumping and Seasoning**

Copper anode, glass foot tube and mushroom-shaped exhaust tube are carefully gauged and graded to ensure accurate joining on the machines, which are quite novel in design and construction. The advantage of this annular seal is that the spacing between the lead-in wires is the maximum attainable for a valve of given diameter, and the insulation between them is thus perfect. Now follows the pumping process. Any evolution of gas during the life of a valve will lead to failure, and it is thus essential to remove all the occluded gases. To do this thoroughly each part of the valve must be

heated to a much higher temperature during pumping than it attains while operating. Fortunately, however, the construction, with its air-cooled metal anode, permits of the application of much higher temperatures than can be applied with glass valves, thus making possible a higher degree of evacuation.

After sealing off from the pump the valve has to be capped before going through the seasoning and ageing processes. In

a new method of capping evolved for the Catkin valve, the base is attached by means of a compressed rubber ring. Rubber has the property of adhering more and more firmly to the glass as time goes on. And this method removes the risk of loose bases. The rubber mount-

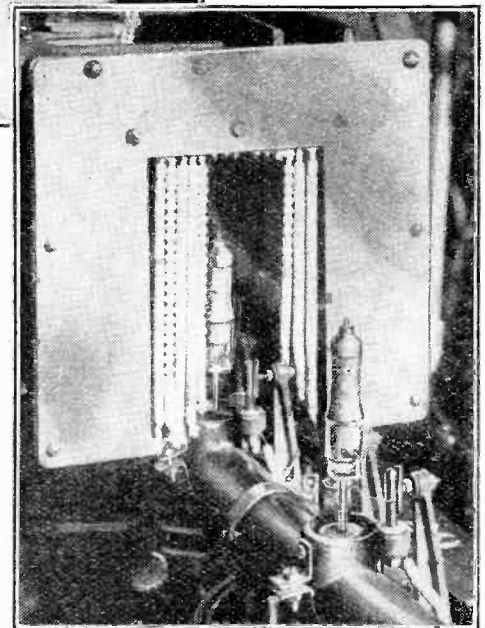

Preparatory to sealing off. "Catkin" valves entering the baking oven on a round table pump.

ing also helps to protect the valve from external vibration and consequent microphonic noise.

A photograph on this page shows the method. The metal shell has a thin rubber ring held between the groove and the flanged top under which the valve is inserted in the press. A bakelite insert carrying the usual pin arrangement is introduced at the other end of the shield, which is spun over so as to retain it permanently in position. When one of these pins forms the anode terminal, connection is made by a wire brought down inside the rubber from a metal ring gripping the anode. In the screen-grid valve, where the anode terminal is at the top, this takes the form of a brass cup which makes direct and permanent contact with the anode. In those valves in which the external metal container is omitted,



**The Catkin in the Making—**

the anode is coated with an external layer of black enamel, which is heat resisting and a perfect insulator. In operation the anode runs at a perfectly safe temperature with or without this enamel coating, but the coating, being black, naturally increases the cooling. The majority of valves, however, require the metal shield to provide electrostatic screening.

In the Catkin a metal shield, shown in the illustration on page 358, is placed over the entire valve and spun on a base so as to fix it permanently. The sides of the shield are perforated to allow free circulation of air to the anode, and it is claimed that this shield gives more perfect screening than sprayed metal, while the

sides, of course, protect the valve from damage.

Each valve is submitted to stringent tests for filament continuity and current anode current, mutual conductance, insulation, etc., and the feature of these tests is the uniformity of results which is inevitable by reason of the precise and rigid manner of construction.

If the listener is happy to have an unbreakable valve so is the packing department at Hammersmith. Elaborate packing is now unnecessary and the cartons can be much reduced in size. The set-maker is happy because no separate valve padding is needed, and, indeed, the set can be despatched complete with Catkin valves ready in their correct positions.

when the driver of a car suddenly stands on his brakes while the man in the car behind is gossiping with his lady friend.

Each car is equipped with a photo-electric cell mounted in such a position that the tail light of a car close in front shines into it and causes it to do its stuff. Now the aforementioned stuff is done, of course, via the customary valve amplifier, and consists of shutting off the steam and jamming on the brakes, thus preventing what might otherwise be a regrettable incident. The driver can thus give all his attention to his fair companion without risk of bumping the man in front. If made compulsory by law it would, of course, make motoring much easier.

To my mind, however, its legal adoption would confer a greater boon on the pedestrian than anything else, as by strapping lights on to his legs at a suitable height he would literally become his own life-preserver, provided that the photocell device was fitted also on bikes and trams, which it very well could be.

# UNBIASED

By **FREE GRID**

## Second-hand

I AM not personally very well acquainted with the good folk whose happy fate it is to dwell in the Midlands, but, unless they are the meekest and most spineless set of morons, they will certainly be up in arms against the latest decision of the B.B.C. Moguls at Portland Place.

It is well known that when the new National transmitter opens at Droitwich next year the local Nationals are to be closed down and at the same time the Midlands are to be supplied with a brand new regional transmitter. At any rate, the Midlanders imagine that it is going to be brand new, little wotting of the fact that, according to a well-known "daily," the B.B.C. are conspiring to palm off on them second-hand goods in the shape of the rickety old affair that has gallantly held the "National" fort at Brookmans Park during the past four years.

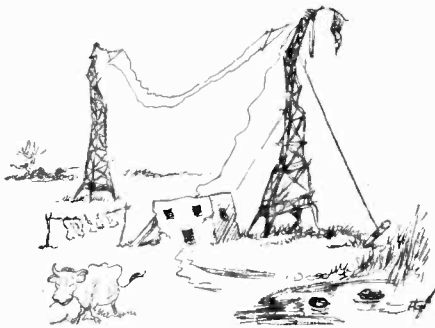

Rickety old affair.

Now I have previously pointed out in these columns (May 12th, 1933) that, according to strict actuarial tables, the normal expectation of life of a broadcasting transmitter is five years, after which it is so archaic, owing to modern developments, that it is fit only for the Science Museum at South Kensington.

If the B.B.C. engineers try to tell us that a 1929 transmitter is still fully up to date, then their Research Department

must compare unfavourably with those of certain component manufacturers whom I would like to mention, but mustn't.

## Follow the Arrow

THERE is one thing in the way of publicity which both the London and the Manchester show authorities might well borrow from Glasgow. I refer to the truly nobby idea of decorating every tram standard with a brightly coloured arrow labelled "Radio" and pointing the route to be followed to get to the Exhibition Hall. The idea needs some improvement, however, for, as it was, it nearly landed me in a somewhat undignified situation.

As I came out of the Central Station at Glasgow I dutifully followed the arrows up hill and down dale for fully a mile until I came to the last. This pointed compellingly towards an attractive entrance way into which I barged without hesitation. I presented my "Kelvin Hall Season" to the handmaiden presiding at the receipt of custom, whereupon she said: "I winna sairve ye," or words to that effect, quoting as her authority the clause in an Act which forbids the serving of intoxicants to already inebriated persons.

The R.M.A. arrow-fixers should be more careful.

## Self-preservation

THE recent Motor Show was interesting to radio enthusiasts if for no other reason than the presence of car radio. I was surprised, however, to note the absence of a major application of the principles of radio or at least of the thermionic valve and its cousin, the photo-electric cell. I had heard all about this new device in a neighbouring foreign country to which I repaired during the first week in October as a sort of meteorological antidote to Manchester.

The apparatus was mainly intended to prevent that type of motor accident caused



Own life-preserver.

I have suggested this to the promoters of the device, who have accordingly invited me to be the leading pedestrian participator in the preliminary trials, which are to be held next week. *Au revoir.*

## Amateurs and the Navy

A SCHEME whereby ships of the Home Fleet may undertake tests in collaboration with members of the Royal Naval Wireless Auxiliary Reserve is already being realised. H.M.S. "Pangbourne" is already taking part in certain exercises with No. 1 District (London).

The Reserve has now been in existence for one year, and the membership has now increased to 225, as compared with 110 in February last. Of these, 60 are members of the Radio Society of Great Britain, and 44 are transmitters. The training has been continued systematically both by verbal instruction and by wireless. Of all the districts, No. 1 (London) has the greatest advantage in that most of its members are able to attend at the Admiralty for instruction on Monday and Thursday evenings. The method of training in other districts has offered greater difficulties, but instruction is being carried out slowly but steadily by wireless.

The ultimate object of the Reserve is to provide those radio enthusiasts who are attracted by service in the Navy in the Telegraphist Branch the opportunity to utilise their special abilities in the service of their country.

Those interested should apply for particulars to the Office of the Admiral Commanding Reserves, Queen Anne's Chambers, Tothill Street, London, S.W.1.



# Broadcast Brevities

By Our Special Correspondent

## "They Won't Pay Up"

IT is strange—or is it?—that the abolition of the Zone system in Empire broadcasting has been regarded in some quarters as the handwriting upon the wall, fate knocking at the door, etc. It has been more than whispered that the B.B.C. is losing interest in the whole affair, not being able to see any likely return for its money.

"Empire and Colonies are not responding," the Jeremiahs have been saying. "They won't pay up."

## The Facts

To be perfectly frank, I believe that the B.B.C. has long since abandoned any hope of a direct financial return for the Empire service. Yet, although the Corporation is spending at least £45,000 per annum on Empire broadcasting, it is not one whit worse off than it would be if it were to close down the Daventry short-wave station to-morrow.

## And Why?

If the £45,000 were not spent on the Empire transmissions, the money would be appropriated by the Treasury.

So, in any case, your money and mine would be used up in one way or the other. In the circumstances, I vote for Empire broadcasting.

## A Big Job

Cecil Graves, originally the Director of Empire Broadcasting, now combines this job with that of Foreign Director, and concerns himself not only with making the Empire "Britain-conscious," but in arranging broadcast relays with foreign countries and building up understanding between the B.B.C. and similar organisations abroad.

Actually, though people have not yet realised it, Capt. Graves' job is going to be one of the most important at "B.H."

## Grown-up Children

PROBABLY 75 per cent. of listeners to the Children's Hour are adults. I may be challenged on this point, but I sit composedly on a bundle of statistics which also go to show that children form 75 per cent. of listeners to the alternative dance music.

All this is by the way.

## Official

The piece of official news that I really wish to communicate is that we are to be spared Children's Hours run by the children themselves. This is splendid.

Children are notoriously bad at entertaining each other, not to mention their adult companions.

## This "Wireless"

IN the rooms of the chiefs at Broadcasting House the walls are now decorated with a new map showing the disposition of land lines all over the country.

I took the trouble last week to count up the number of miles covered by this vast network. It appears that the B.B.C. is now using some 4,500 miles of wire to connect about twenty stations and control points. Between certain stations there are as many as ten cables. And they call it "wireless."

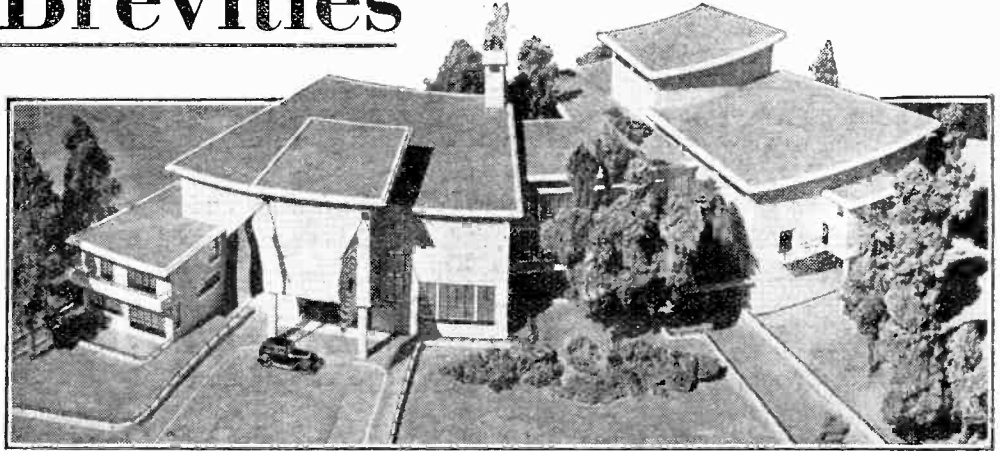

DESIGN IN MODERN BROADCASTING.—A clever model of the new "Broadcasting House" now under construction at Hilversum for A.V.R.O., the Dutch independent broadcasting association. The building will incorporate a studio to suit every type of programme.

## "La Vie Parisienne"

A TWO-PART broadcast takes place on November 13th and 14th, when "La Vie Parisienne" will be heard—Part One on the National, and Part Two on the Regional wavelength. In the plot of the stage version by A. P. Herbert and A. Davies Adams a great deal of the comedy depended, as might be expected, upon visual effects. The plot has been a good deal simplified for broadcasting. The characterisation remains the same, and, of course, A. P. Herbert's lyrics and the music of A. Davies Adams remain.

## A "Stay-at-Home" Night

The original French lyrics have been translated into English, and it has been necessary to make a few alterations in order to clarify the plot for the benefit of listeners. I am told that there will be a maximum of music and a minimum of dialogue and effects, so the evening promises to be an enjoyable one.

## Lady Announcers for the Provinces.

ALTHOUGH the voice of Mrs. Borrett may no longer be heard in announcements on the air after Sunday next, I can state that women announcers will occasionally be employed at provincial stations.

## Bravo, Mrs. Borrett!

Incidentally, everyone must admire the courageous manner in which Mrs. Borrett has carried out her duties since the announcement of her impending departure. It is unusual in most walks of life to expect anyone to continue to work in the blaze of publicity after an unfavourable decision has been made known to the world at large, and I, for one, am surprised that the B.B.C. should have followed their present course.

But Mrs. Borrett is keeping the flag flying to the end.

## Pepping Up the Politicians

ALTHOUGH the average politician at the microphone lacks the sparkle of Tommy Handley or Gillie Potter, there may be an improvement very soon. The denizens of Westminster are seriously studying microphone technique, as witness the latest experiment of the Conservative Party, which is providing a special course on "Broadcasting and Public Opinion" at Ashridge during the week-end covering December 10th.

## How to Talk to "Mike"

Lord Bridgeman, one of the B.B.C. Governors, will open the course and Capt. Ian Fraser, M.P., will deliver a special address on "Talking to the Microphone." Other speakers will be Lord Allen of Hurtwood, on "The Significance of Broadcasting"; Professor Ernest Barker, on "The Constitution of the B.B.C.," and Sir Charles Petrie, on "Broadcasting and International Affairs." Who knows but what "Political Nights" may not be the rage next year?

## A Bawler-Back?

These political nights would provide good scope for testing an idea submitted to one of the daily papers last week.

"Perhaps," wrote a correspondent, "the B.B.C. might think out some method of answering back for listeners who do not like the opinions they hear. Why not a *representative broadcasting listener* to bawl back at the B.B.C. bawlers?"

I suggest "Free Grid."

## Eric Gill Statue Comes to Life

SPECIALLY adapted for broadcasting, Shakespeare's "Tempest" will be heard by National listeners on November 12th in a Prologue and seven scenes. Val Gielgud and E. A. Harding are responsible for the adaptation, and music has been composed by Kate Coates and Leslie Woodgate.

Prospero is to be that well-known actor, John Gielgud, while the part of Ariel will be played by Leslie French, who, it may be recalled, provided the model upon which Eric Gill, the famous sculptor, based his interpretation of an Ariel in human form for the group which adorns the main entrance to Broadcasting House.

## Henry Hall's Boys at Play

FRANKIE WILSON, one of the trumpeters in Henry Hall's band, captained the "boys" in a football match on the B.B.C. ground at Motspur Park on October 26th. The opposing team was composed of Scotsmen drawn from various dance bands in the London district.

I should say that the B.B.C. boys had the advantage, for the referee was Burton Gillis, the leader of the band, who stands 6ft. 7in. high in his socks and weighs seventeen stone. There is a prejudice in favour of not quarrelling with referees of this build.

However, they lost by 2 goals to 1.

# How to Use Valve Load Diagrams

**T**O get a proper understanding of what a valve is doing and to know when it is being used efficiently, it is essential to understand how to read valve load diagrams. Unfortunately, on the incorrect assumption that it is a complicated business, many people shirk trying to understand them. The purpose of this article is to explain both the preparation and use of these diagrams in the simplest possible manner.

## Vital Information by Graphical Methods

By M. G. SCROGGIE, B.Sc., A.M.I.E.E.

**V**ALVE curves, like guardsmen's uniforms, are divisible into two classes—the ones to be looked at and the ones to be used. Those printed on the slips accompanying the valves and in the less detailed catalogues are usually of the former class, and are fairly easy to understand, though it is of relatively little importance whether they are understood or not, for they give only

The apparent difficulty probably consists of the representation of current, voltage, resistance and power all at once on a single diagram. This would indeed be confusing if these were all separate and independent quantities, for it would involve four dimensions; a condition popularly associated with the occult. But there are really only two dimensions—current and voltage—and they can be represented as height and breadth on a piece of paper. The other two quantities are combinations of the first two. Power is current multiplied by voltage, and as height multiplied by breadth is area, power appears as area on the diagram. That seems quite sensible. Then resistance, according to friend Ohm, is voltage divided by current. That may appear less easy to show on the diagram, unless one remembers that a *gradient* of, say, one in four, is represented by the fraction  $\frac{1}{4}$ . So it is reasonable to suppose that one divided by four can be represented as a gradient. A resistance of 1,000 ohms, or one volt divided by one milliamp., is represented by a line sloping one milliamp division up for every volt division along.

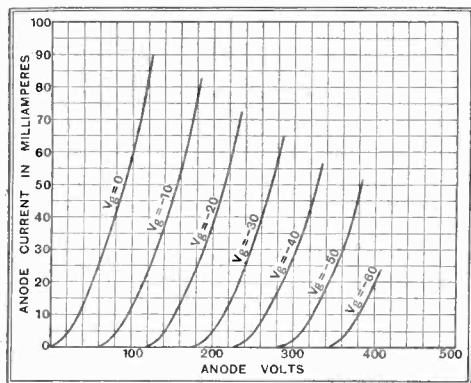

Fig. 1.—Typical set of anode volts/anode current curves for a triode valve.

very general information—not even enough to distinguish a pentode from a triode. They are of the type which show scales of anode current and grid voltage, with a separate curve for each anode voltage.

The other sort look very much the same except that anode and grid voltage have changed places. They can be used to disclose a great deal of useful information about the valve to which they refer, but as it is necessary to add a number of mysterious curves and straight lines, many readers no doubt prefer to do without the information rather than wrestle with the intricacies of the diagram.

This is a pity, because it is really quite easy to master the valve load diagram, as it is called, and thereafter form a very clear mental picture of what a valve is doing, and whether it is doing it properly. In particular, one is able to compare for oneself the merits of different types of valves, with three, four, five or more electrodes, that are offered for any particular job.

### Anode Volts—Anode Current

Now, looking at Fig. 1, which is a typical set of curves for a triode power valve, the anode voltage and anode current scales are shown extending horizontally and vertically. The lines sloping upwards to the right represent the behaviour of the valve. The one marked  $V_g = 0$  was obtained by making the grid bias equal to 0 and gradually increasing the anode voltage, noting the corresponding current. The height of any point on the curve was made to mark the current at the voltage represented by the distance to the right. The same was then repeated with a grid bias of 10 volts, giving a very similar line shifted to the right, and so on for other bias voltages. There could be, of course, an infinite number of such lines, but one can imagine the intermediate ones fairly easily.

According to what has just been explained, if another valve's lines sloped more steeply it would show that that valve

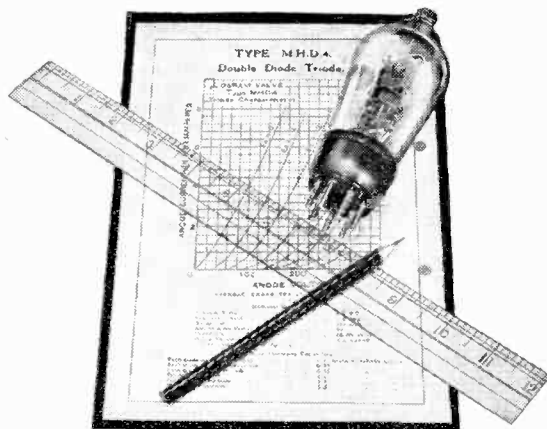

had a lower anode resistance. The other resistance that enters into the combination in order to obtain a useful result is the resistance of the load, which may be a loud speaker. This resistance is distinguished by sloping up to the *left*, but at the moment we don't know where to put it. First of all certain areas must be declared out of bounds, as in Fig. 2.

All the space to the left of the  $V_g = 0$  line corresponds to positive grid voltage, which with ordinary valves results in grid current and distortion; so that area is forbidden. Then the valve curves must be reasonably straight and evenly distributed or another form of distortion is caused; this requirement cuts out the strip close to the voltage scale. Just how much is cut out will be seen later. The third boundary is laid down by the maximum amount of power that the valve can take without overheating, and is usually approached only in an output stage. In the particular valve illustrated the limit is 12 watts. A power of 12 watts is represented by a rectangular area having two of its sides formed by the volt and milliamp scales, and the other two chosen to enclose the right amount of space. For instance, 250 volts and 48 milliamps multiply up to give 12,000 milli-watts, or 12 watts, so that is one area that fulfils the condi-

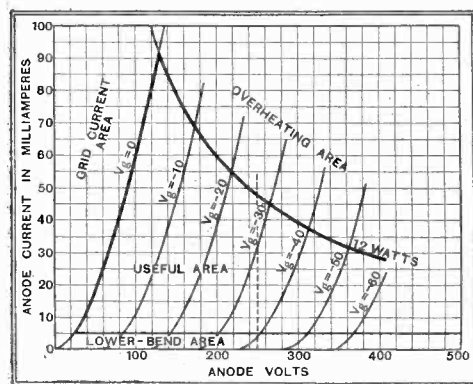

Fig. 2.—Areas that must be ruled "out of bounds" through various causes.

tions. But it is better not to trouble marking off its four sides, because there are endless numbers of other areas that also represent 12 watts, and it is enough simply to put a dot at the top right-hand corner. If the same is done for a number of other pairs of numbers such as 120 and 100, and



**How to Use Valve Load Diagrams.—**

300 and 40, and the dots are joined up, a curved line is produced and may be marked "12 watts." The line itself does not represent 12 watts; it indicates that any rectangular area which does not poke above it is within the 12-watt limit.

Having thus laid out the pitch, we are free to move within it. A starting point must be chosen, by selecting the right anode voltage and grid bias, such that the

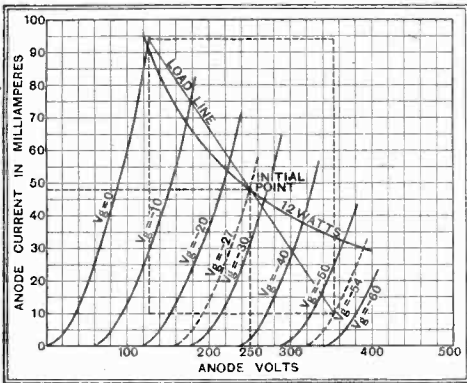

Fig. 3.—Adding the load line and completing the power rectangles.

fluctuations of current and voltage that take place when the valve is working can be represented by a line, the load line, extending each side of it. The object presumably is to get the most out of the valve, and is represented by making the load line as large as possible. The importance of the boundaries begins to appear at this stage. We have seen that the slope of the load line represents its resistance, and in a sense its length represents the output power which is actually delivered to the load, because, being a sloping line, it may be looked on as the diagonal of a rectangular area, and area is power on the diagram (Fig. 3). So, to find the output power, complete the rectangle, either with a pencil or with the eye, and divide the area by 8\*.

**Drawing the Load Line**

The line must not be drawn just anywhere; there are definite rules. The starting point, to which the valve is adjusted by bias or H.T., must be at the centre or very near it. Then next, the load line must cross as many grid volt lines on one side of the initial point as on the other. Thus, if the initial point is at a bias of -30, and it extends to 0 on the one side it must go to -60 on the other; and if it cannot do this and still keeps the initial point within 5 per cent. of its centre, it is disallowed. It is this requirement that calls into existence the boundary at the foot, where the grid voltage lines crowd up together and if used would make the

\* The vertical side of the rectangle represents the current "swing" or twice the peak current, or  $2\sqrt{2}$  times the r.m.s. current. Similarly for voltage. So the power output, which is r.m.s. current multiplied by r.m.s. voltage, is equal to current swing  $\times$  voltage swing.

$$\frac{2\sqrt{2} \times 2\sqrt{2}}{\text{area of rectangle around load line}}$$

two halves of the load line flagrantly unequal.

The zero-bias boundary must also be strictly respected, and the 12-watt line must not be passed by the fixed initial point, because it would be "caught out" by the excessive rise in temperature. This rise is fairly slow to act, however, and the working point, whose excursions trace out the load line, is able to cross into forbidden territory because it does so only for a fraction of a second and then it is back again before the temperature has time to realise that anything is wrong.

**Maximum Power Output**

Suppose we take the field and go all out for the full 12 watts that can be put into this particular valve without causing it to get unduly heated. Any point on the 12-watt line represents an adjustment that would cause the valve to draw 12 watts from the supply, but generally the anode voltage is restricted either by the makers' advice or by convenience, and in this valve is taken to be 250. Running upwards from the 250-volt mark to meet the 12-watt line (Fig. 3), the initial point is fixed, and so is the grid bias, which is

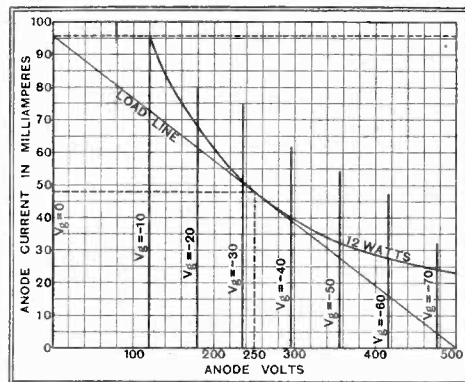

Fig. 4.—An unattainable ideal; the load diagram for a perfect valve.

between -25 and -30; call it -27. And of course the anode current is likewise fixed, at 48 milliamps.

The load line can be drawn to the left until it hits the boundary, in which case it has traversed 27 grid volts. So according to the rules it must go 27 volts in the other direction, to -54.

If the load line is made very steep, almost vertical, it can go a long way up, but only a much shorter distance down, and that breaks the rule which requires the starting point to be within 5 per cent. of the true centre. So to make that right it would be necessary to shorten the line at both ends, which is not at all what is wanted. If the line is made nearly horizontal, that is to say, if the loud speaker or other load is very high in resistance, the previous difficulty is avoided, but the area drawn with the line as diagonal is very small. So it is best to choose an intermediate position, like that shown, which makes the initial point come roughly half-way between the two boundaries.

Two dotted rectangles are shown; the one drawn round the load line has an area that represents eight times the useful

power put into the load by the valve. The other represents the power put into the valve. If the valve were a perfect device it would give as much as it got, and these would be equal; the load area would be eight times as great as the other one. But the two areas are much more likely to be nearly equal, or at most in the ratio of 2 to 1. So that most of the power put into the valve is wasted.

Looking about, as we all must be in these days, for causes of waste, we see that if the left-hand boundary were removed the load-line area could expand without affecting the input power area. To make the boundary disappear the valve curves would have to be vertical, and as a vertical line means zero resistance, it is the same thing as saying that the valve would have to have no A.C. resistance. This is not practicable, but Fig. 4 shows what the diagram for a perfect valve would look like. It is quite obvious that the load-line area is four times as great as the input power area, so the output is half as great as the input. Thus the maximum efficiency even of a perfect valve is only 50 per cent., provided there is no distortion.

**D.C. Dissipation and A.C. Output**

The last stipulation is important, because if the valve is operated where the lines crowd up at one end, so as to cause severe distortion, the efficiency is improved.

In Fig. 5, where this effect is represented, it is obvious that the large dotted rectangle around the load line is more than four times the size of the small rectangle in the lower left-hand corner, and therefore the output is more than 50 per cent. of the input. To take an extreme case, if one half of the wave is cut off entirely, so that it must be supplied by another valve, as in the Q.P.P. system, the theoretical maximum efficiency is  $\frac{\pi}{4}$

otherwise  $\frac{3.14}{4}$ , or nearly 80 per cent.

That is an advantage entirely in addition

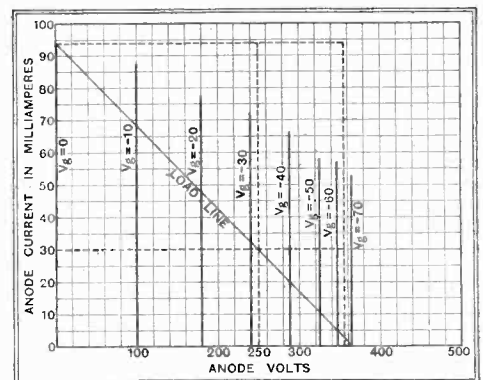

Fig. 5.—Load diagram of a valve with an efficiency of over 50 per cent.

to the primary object of the system, which is to restrict the current to that actually required at any moment, and so avoid letting it run to waste during intervals and quiet passages. Therefore, even when working at full power there is a substantial saving.

Fig. 3 has shown the rather poor actual

**How to Use Valve Load Diagrams.**— efficiency of a triode valve, and Fig. 4 the maximum in an ideal theoretical valve. There is, however, a better approximation to the latter than the triode, and Fig. 6

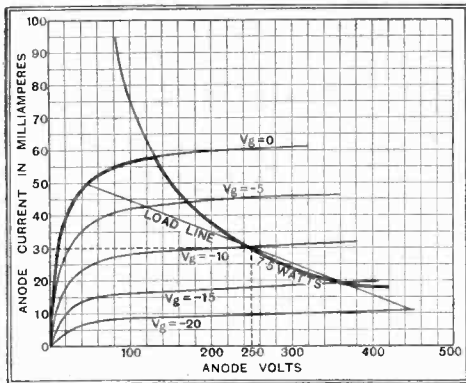

Fig. 6.—Showing why a pentode is inherently more efficient than a triode.

shows how the peculiar shape of the pentode curves pushes back one of the boundaries and gives more room for fitting in a large load line. The anode voltage can

swing right down to about 40, whereas the triode of Fig. 3 wastes the first 130 volts. A triode cannot in real life do much better than 20 per cent., but a pentode can do 30 per cent., or even 40 per cent. An efficiency of over 50 per cent. has been claimed, and this condemns itself with its own mouth, because it can be obtained with a single valve only by distortion.

Nevertheless the load diagrams make quite plain why a greater amount of sound can be obtained with a pentode than with a triode, the power supply being the same for both; or alternatively the same amount of sound for less power in the case of the pentode. They also make plain a strong point in favour of Class "B" amplification, employing special triodes in which the grid current restriction is abolished, and with it the lost space on the left. The overheating boundary also is virtually abolished, because at the initial point the anode current is nearly zero, and even when working "all out" the temperature rise is not likely to be anywhere near the danger mark.

Fig. 7 shows a diagram for a Class

"B" valve, which is a very close approach to the theoretically perfect. An actual efficiency of well over 50 per cent. is obtainable. It has the unique combination of three claims to efficiency:—

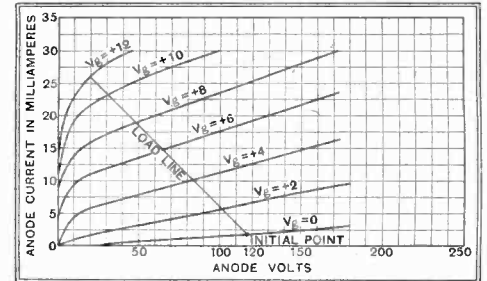

Fig. 7.—Diagram of a Class "B" valve, showing how nearly it approaches the theoretical ideal.

- (1) The theoretical limit of efficiency is nearly 80 per cent.
- (2) Owing to the shape of the curves this limit is approached more closely than by other valves.
- (3) The efficiency at low power is maintained by the quiescent effect.

## News of the Week

### Current Events in Brief Review

#### A Gift to Listeners

A FREE gift is offered to listeners who pick up the English talk of Mr. Thad Ordon, which he is delivering from the Warsaw broadcasting station to-morrow evening (Saturday), at 9.10 p.m. (G.M.T.). His subject is "The Fifteenth Anniversary of the Polish Republic." To prove that they have actually heard the talk listeners should make their claim for the actual gift to which Mr. Ordon refers. Claims should be addressed to *The Wireless World* to be forwarded to the station.

#### Indian Arrows for DX'ers

A SET of Indian arrows is to be awarded to the short wave listener in any part of the world who gives the most complete report on the special 42-metre transmission of the International DX'ers Alliance on Monday, November 13th, between 1 and 3 a.m. (G.M.T.). The transmission is made from YV2AM at 7 and 9 p.m. (C.S.T.) on Sunday, November 12th. Reports must be sent to the I.D.A., Bloomington, Ill., not later than December 31st.

#### Where Denmark Leads

"WHO are the most ardent listeners to foreign programmes?" asks a Continental correspondent. It is believed that the Danes are high on the list, as it is estimated that nine-tenths of Danish listeners are ether-searchers. This must not be interpreted to indicate apathy towards their own programmes, but is in keeping with Denmark's record of being the most "radio conscious" country in Europe. For some years Denmark has had more listeners per head of population than any other country in Europe.

#### Only a Relay

RADIO-BARI has now lost its individuality, having at last been connected directly by land line with Radio Roma.

#### Payment to Composers

PROMPTED no doubt by the recent activities of the Performing Right Society in this country, French authors and composers recently met in Paris to discuss "the basis of a proper remuneration" in respect of items broadcast. Now that the new radio tax is bringing millions into the Treasury, the composers consider the time is ripe.

#### The Beam Link

LAND line maintenance is a difficult proposition in northern Norway, and the broadcasting engineers have abandoned all hope of relying on the trunk line connection between Oslo and Vardö, where Europe's most northerly broadcasting station is being built. So it has been decided to instal a special short-wave beam transmitter for the sole purpose of radiating the programme to Vardo for retransmission. The new station will open early in January.

#### International Move Against Static

EUROPE is in earnest on the question of eliminating interference with radio reception and the International Electro-technical Commission, which first met in Paris in June last, has now constituted a special committee to get at the heart of the matter. The chairman will be Dr. A. F. Enstrom (Sweden), and seven experts are to be appointed to represent Germany, Great Britain, Holland, Denmark, France, Italy and Rumania. There will also be two representatives of the International Broadcasting Union, and one representative each of the International Union of Producers and Distributors of Electrical Energy, the International Conference of Large High Electric Systems, the International Union of Railways, the International Union of Tramways, and the International Commission of Aerial Navigation.

We learn that the British National Committee of the I.E.E. has been invited to act as Secretariat of the special Committee of Interference, the work to be carried out by the Committee which has recently been appointed by the Institution of Electrical Engineers.

#### For Every-Day Use

WE live in stirring times and nearly everyone nowadays keeps some sort of record of passing events. *The Wireless World* Diary not only offers the radio user the best means of keeping his "daily log," but supplies a mass of easily accessible information on all matters pertaining to his hobby. The 1934 Diary tabulates all the European wavelengths under the new Lucerne Plan, and includes receiver maintenance record pages, abacs for instantaneous calculations, useful formulæ, wireless symbols, and tested circuit diagrams, in addition to practical hints and comprehensive valve tables. It is obtainable from all booksellers, price 1s. 6d., or from our Publishers, Dorset House, Stamford Street, London, S.E.1, price 1s. 7d., post free.

#### The Arctic Radio Expedition

THE actual receiver used by the British Radio Expedition to the Arctic Circle was shown in operation on Friday last, October 27th, when Professor Appleton gave an evening discourse at the Royal Institution. The receiver measured the height of the Heaviside and Appleton Layers, using pulses of energy emitted from King's College, Strand.

Professor Appleton showed records of the slides definitely indicating that during magnetic storms, which are of frequent occurrence in Arctic latitudes, electrification at the lowest levels of the Heaviside Layer was increased to such an extent that wireless waves were completely absorbed in this region. Accordingly the Layers could play no part in reflecting them, and this accounted for the frequent inability to transmit wireless waves across the North Pole.

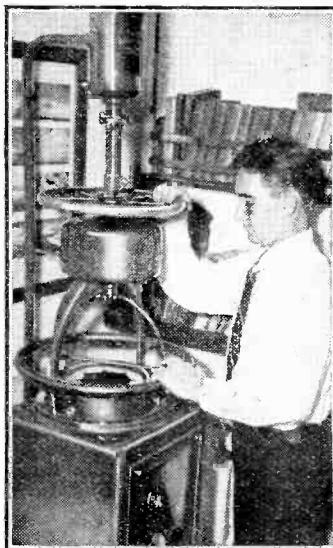

IN TOUCH WITH THE ANT-ARCTIC. The direction finder installed at East Boston, Mass., to enable operators to locate the Byrd Antarctic Expedition during its forthcoming two-year trek across the South Polar regions.



# Sunbeam Model M30

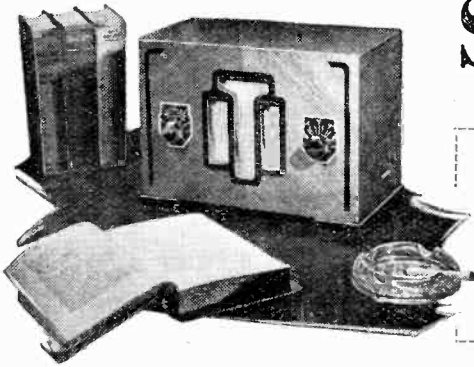

**FEATURES. Type.**—Midget table model receiver for A.C. or D.C. mains, incorporating a moving coil loud speaker. **Circuit.**—Variable-mu H.F. valve—grid detector—pentode output valve. Half-wave valve rectifier. **Controls.**—(1) Tuning. (2) Volume and on-off switch. (3) Wave-range. **Price.**—7 guineas. **Makers.**—Sunbeam Electric, Ltd., Sunbeam Road, London, N.W.10.

## A Portable Midget Receiver for A.C. or D.C. Mains

**M**EASURING only 10½ in. × 8 in. × 5½ in., and with a permanently attached flexible aerial lead, this little set makes an ideal "personal" receiver for the home. No earth connection is necessary, and it may be used anywhere within reach of a mains supply point. The power supply circuit is universal, and it can be plugged into either A.C. or D.C. mains without any adjustment other than the obvious precaution of seeing that the voltage plug inside the back of the set is connected to the socket corresponding with the mains voltage. On D.C. mains, of course, the polarity is important, and it may be necessary to reverse the mains plug if the set is unresponsive after the usual warming-up period has elapsed.

The controls comprise a combined mains switch and volume control on the left, and a tuning control on the right, and a waverange switch at the side of the cabinet. A miniature calibrated scale is provided showing very approximately the wavelength to which the set is tuned. Normally, greater accuracy is not required, as, with the short aerial provided with the set, it is unreasonable to expect to receive stations other than local regionals, and these are easily tuned in by ear without reference to the scale.

Inside a steel-framed building in Central London both Brookmans Park stations came in with adequate strength, but the long-wave stations were not so good, and the outdoor aerial was required to obtain the

necessary strength. In a brick-built house a much higher volume level is to be expected on the 25ft. indoor aerial.

An energised moving-coil loud speaker is incorporated, and the quality is pleasant and unmarred by any pronounced bass resonance. Speech is excellent, and the response is able to do justice to all the popular programme items.

The circuit comprises three stages—a screen-grid H.F. amplifier tuned anode coupled to screen-grid detector and followed by a resistance-coupled pentode output valve. The aerial circuit is isolated by fixed condensers, so that there is no danger from electric shock—an important consideration when the set is used on D.C. mains. Both tuning condensers are accurately ganged, and volume control is effected by varying the bias of the variable-mu H.F. valve.

The valves are of the indirectly heated

type, and the filaments, which are rated at 20 volts and 0.18 amp., are joined in series and connected through a voltage-dropping resistance to the mains. The heat generated in this resistance is appreciable and might give rise to trouble if it were mounted inside a cabinet of such small dimensions. The makers have neatly solved this problem by incorporating the resistance in the mains supply cord. This accounts for the slight temperature rise in the cord while the set is working. Naturally, the cord must be treated with more care than is generally shown to flex, but if, for any reason, it should fail, a replacement can be obtained from the makers. Incidentally, a very full range of spares is listed, and the instructions

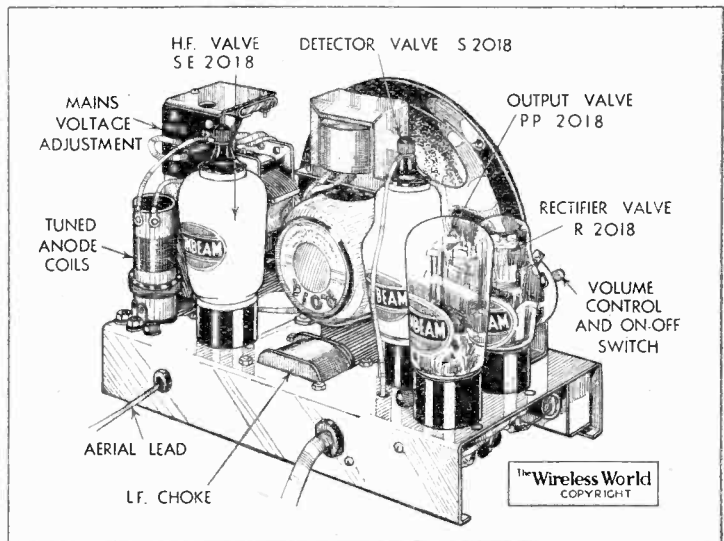

An energised moving coil loud speaker is incorporated in the chassis. Tungram valves are used throughout.

folder gives the normal voltage readings at different points in the circuit.

The half-wave rectifier for A.C. consists of a triode with the grid and anode strapped together. It is connected in series with the supply, and there is thus nearly the full H.T. voltage between the heater and cathode. These valves, however, are well able to withstand the voltage at this point. The loud speaker field is connected in parallel with the H.T. supply, and a separate choke is used for smoothing. On A.C. mains the hum is inaudible at a distance of more than two feet.

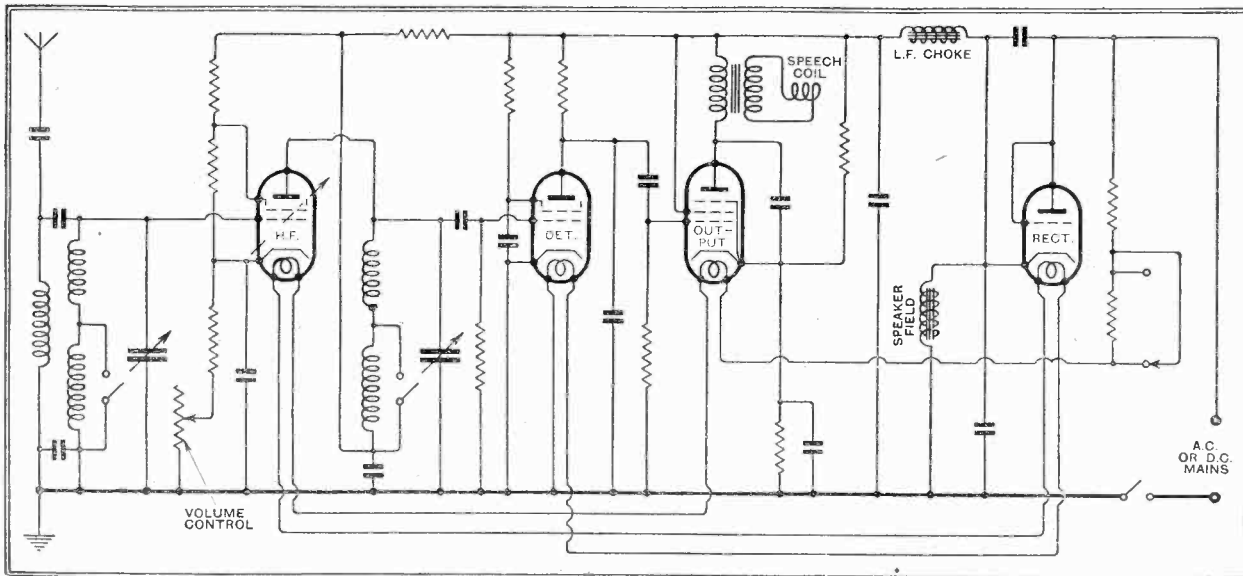

Complete circuit diagram. The series filament resistance is integral with the mains supply lead.

Next Week's  
Set Review :  
CLIMAX S.4.

# Practical HINTS and TIPS

MANY users of D.C. mains sets who are considering the fitting of a gramophone pick-up are probably unaware that certain precautions should be taken when making this addition. The external pick-up connections may be at a high potential with respect to earth, and so something must be done to avoid the risk of shock or possible damage; clearly, complete isolation, from the D.C. point of view, must be provided between the pick-up and the mains.

## Isolating the Pick-up

Unless isolating condensers are fitted, a gramophone pick-up connected to a D.C. mains set will be "live"; with a positively earthed supply damage may be caused.

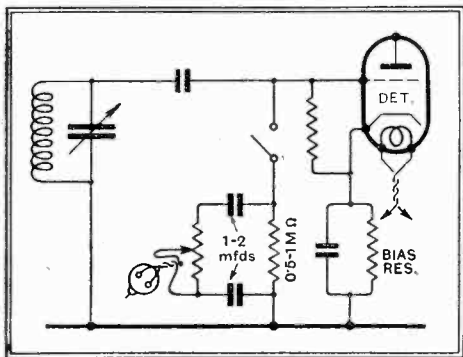

Fig. 1.—Unless isolating condensers are fitted, a gramophone pick-up connected to a D.C. mains set will be "live"; with a positively earthed supply damage may be caused.

The simplest way of doing this is to fit a double-wound transformer, but unfortunately suitable components for this special purpose are not readily available. As an alternative, there remains the method of isolating shown diagrammatically in Fig. 1. Here D.C. potentials are "blocked off" by a pair of condensers, which, of course, should be housed inside the receiver itself. It must not be forgotten that in order to prevent a choked grid circuit a leak of from 1/2 megohm to 1 megohm must be fitted as shown.

It does not seem to be generally realised that the amount of smoothing required in a mains-operated receiver is more or less directly in proportion to the amount of amplification—particularly L.F. amplification. For instance, the mains equipment of a typical modern set, in which the detector feeds direct into the output valve, would almost always prove to be hopelessly inadequate if the owner for any reason decided to increase L.F. magnification by fitting an intermediate stage between the detector and output valves.

## Amplification and Smoothing

This explains why the D.C. Superhet recently described in these pages is proving so successful in cases where mains hum is usually found extremely difficult to eradicate. Although the new set has sufficient H.F. and I.F. amplification to pro-

## AIDS TO BETTER RECEPTION

vide more than usual sensitivity, the L.F. magnification is probably less than that of any other receiver described in *The Wireless World*, except those in which a pentode performs the combined function of detector and output valve.

USERS of superheterodynes with the modern style of I.F. amplifier are inclined to forget that the quality of reproduction is controlled largely by the degree of coupling between the component circuits of the I.F. transformers. If, for example, reproduction is unduly low-pitched, the defect may well be due to an excessively tight coupling, and the effect of moving the coils farther apart may be tried with every hope of success. Conversely, a deficiency in the bass register may sometimes be partially corrected by a judicious increase in the spacing between the windings.

## Coupling Influences Quality

IT is sometimes convenient to be able to maintain artistic continuity by "fading out" a radio programme in favour of a gramophone record, or vice versa. To make provision for doing this is by no means a difficult matter, at any rate in a short-range "quality" receiver, and probably the simplest way of arranging for an imperceptible change from one method of reproduction to another is that shown diagrammatically in Fig. 2. A tapped potentiometer will be required; usually the extra connection may be made with a little ingenuity on the resistance element of most commercial components.

## Radio-to-gramophone Fader

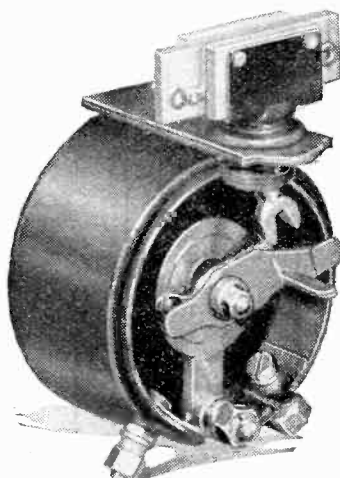

A ganged switch arranged to break contact at an intermediate position of the potentiometer slider travel.

The operation of a fader is quite simple and easy to understand. It will be realised that, with the slider at point Y, the grid

circuit of the valve will be virtually short-circuited, and so there will be nothing fed to it, either from the "radio" or "gramophone" sources. On moving the slider upwards towards point X, the strength of radio signals will be progressively increased from minimum to maximum. Conversely, moving the slider downwards from point Y towards Z will result in the application of an increasing proportion of the pick-up output to the grid.

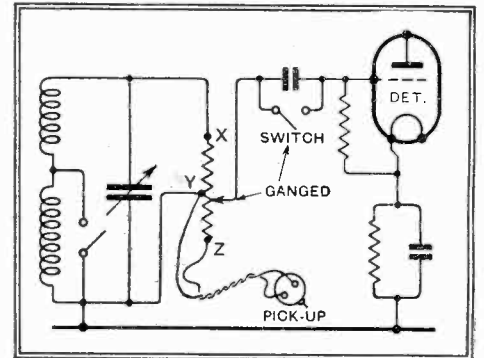

Fig. 2.—A tapped potentiometer with ganged switch, arranged to give continuous volume control and automatic change-over for both gramophone and radio reproduction.

It is necessary that the detector-grid condenser should be short-circuited automatically at the precise moment when the slider passes from the "radio" section of the potentiometer to the "pick-up" section. This can conveniently be done by means of a switch built on to the potentiometer, and it is very often possible to arrange matters so that the switch, instead of breaking or making contact at the extreme end of the travel of the contact brush, will do so at any desired intermediate position. This is shown in the accompanying illustration.

The resistance of the potentiometer between points X and Y should not be appreciably less than 0.25 megohm; between Y and Z it should be that specified by the makers of the pick-up.

THERE is no reason why automatic volume control, if fitted properly and in good working order, should impair the maximum sensitivity of a receiver to the slightest extent. If the addition of A.V.C. seems to be responsible for a reduction in sensitivity, it is advisable to measure the individual anode currents of the controlled valves when no signal is coming in; if current be abnormally low the implication is that the "standing" bias of these valves is excessively high. With certain systems, a defect of this nature may be due to incorrect biasing of the controlling valve.

## Loss of Sensitivity



# NEW APPARATUS REVIEWED

Latest Products of the Manufacturers

## EARL P.M. LOUD SPEAKER

THE latest models of this loud speaker are fitted with a volume control which has been designed to maintain the frequency response irrespective of the setting of the

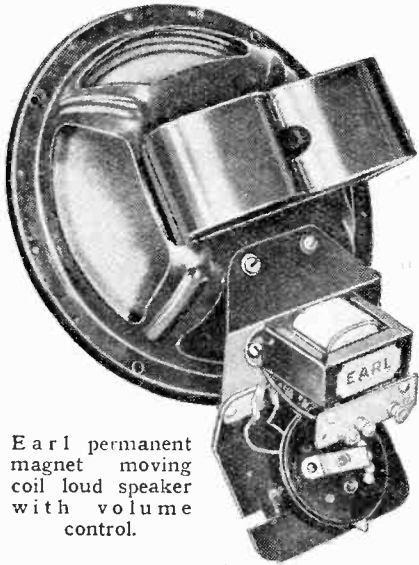

Earl permanent magnet moving coil loud speaker with volume control.

control. It takes the form of a low-resistance potentiometer between the secondary winding of the output transformer and the moving coil. In the maximum position the switch arm is arranged to disconnect the potentiometer resistance so that the full efficiency of the unit is available. At the other end of the range, the primary winding of the transformer is open-circuited, thus facilitating the addition of an external loud speaker to the set.

The unit tested had a useful frequency response from 75 to 4,500 cycles with a principal diaphragm resonance at 95 cycles and a region of increased output around 2,500 cycles. The special method of mounting the cone evidently gives greater freedom of motion, and the volume control does not appreciably affect the balance of tone.

The makers are the Earl Manufacturing Co., Ltd., Avenue Works, Hanover Park, Peckham, London, S.E.15, and the price of the unit with volume control is £2 10s.

## BAKER'S CLASS "B" CONVERTER

MADE by Baker's Selhurst Radio, 75 and 77, Sussex Road, Croydon, Surrey, this unit provides a ready means for con-

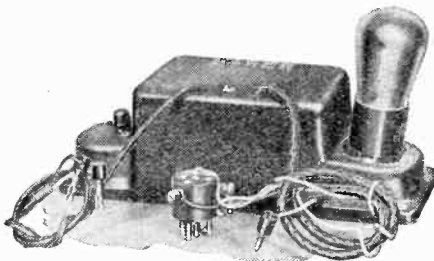

Baker's Class "B" conversion unit.

verting an existing battery set to Class "B" working. An increase in the power output of the order of six times as compared with a low-power triode may be expected, yet very little extra will be required from the H.T. battery. Indeed, a saving might actually accrue, for the average anode current of

the Class "B" valve will rarely exceed seven milliamps.

The unit does not replace the existing output stage, but is used in addition thereto, but this now becomes the driver stage for which a low-power triode of about 150 milliwatts output will suffice. This valve is fitted to an adaptor which plugs into the output valve-holder; the cable joined to this plug has woven with it a lead supplying H.T. to the unit. To operate the unit to the best advantage an H.T. battery of 130 volts is required, but quite good results are obtainable with but 100 volts.

The price of the converter is 37s. 6d. without valve, and it can be obtained fitted with a carefully matched Baker's Permagnet moving-coil loud speaker for 75s. This does not include the valve.

## THE ROBERTS MICROPHONE

THE salient feature of these microphones, which are of the carbon type, is that granules are enclosed between two flexible

Roberts microphones. (Left to right) "Standard," "Experimenter's" and "Lapel" models.

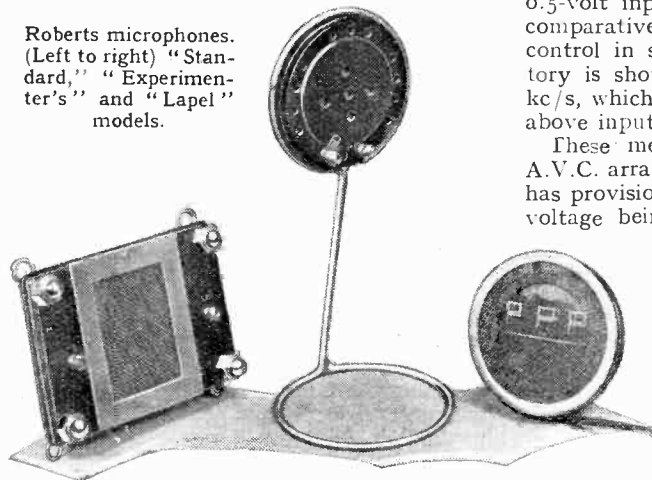

diaphragms instead of the usual single diaphragm with solid back plate. The advantages claimed for this arrangement are that the microphone is practically non-directional, and, in the case of sound waves impinging on the instrument at an angle, the phase difference between the pressure on the front and back results in increased efficiency, particularly at high frequencies.

The standard rectangular model measures 4in. x 2½in. and is ¾in. thick. There is a public speaker's model designed to pin on to the lapel of the coat, and an experimenter's model which should be of interest to amateur transmitters. The latter costs 12s. 6d., and is rubber-sprung in a neat wire stand.

The instruments are designed and made by Capt. A. J. Roberts, 89, Wardour Street, London, W.

## WEARITE AUTOTROL UNIT

THE Autotrol Unit has been introduced by Wright & Weaire, Ltd., 740, High Road, Tottenham, London, N.17, with the view to providing the means for incorporating A.V.C. in receivers with the minimum of alteration and trouble. It is well suited for use in existing receivers, particularly superheterodynes, as the A.V.C. voltage provided is not constant at all frequencies, the highest output being obtained when it is supplied

from a source of H.F. at a comparatively low radio frequency.

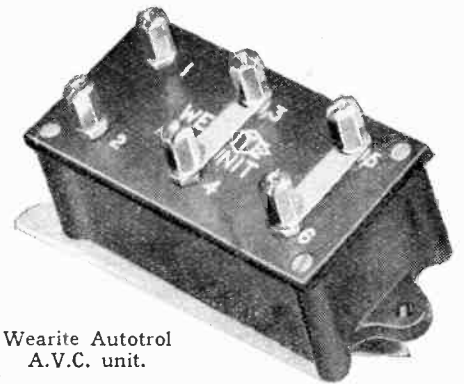

Wearite Autotrol A.V.C. unit.

A measure of control is available, however, on the normal wavelengths, and the measured values obtained on test were 1.3 volts at 1,200 kc/s (250 metres), 2.9 volts at 600 kc/s (500 metres), and 7 volts at 200 kc/s (1,500 metres). These were given with 0.5-volt input to a leaky grid detector of comparatively high amplification. That the control in superhets will be most satisfactory is shown by the D.C. output at 110 kc/s, which in our case was 8.5 volts for the above input.

These measurements were for a simple A.V.C. arrangement, but this particular unit has provision for delayed A.V.C., the delay voltage being obtained from a small grid cell joined to two of the unit's terminals. The scope of the Autotrol is further widened by provision for manual control of the bias voltage fed to the controlled valves, a most useful feature especially where the ordinary type of screen-grid valve with a short grid base is employed.

This unit will serve admirably as an anti-fading device in short-wave sets, yet, despite its versatility, the price is but 10s. 6d.

## GOLTONE STAND-OFF INSULATOR

AN insulating pillar has a multitude of uses, particularly in short-wave work, for it will serve for mounting coils, metres, and sundry other components where it is desirable to raise these above the baseboard. A device of this nature is made by Ward & Goldstone, Ltd., Frederick Road (Pendleton), Salford 6, Lancs, and is known as the Low Loss Stand-off Insulator.

It is made of a porcelain compound, has very good insulating properties, and measures 2½in. diameter at the base and is 1½in. high. A 2BA screw with fixing nuts is provided, but if desired this could be removed and a length of 2BA rod employed instead. The price is 9d.

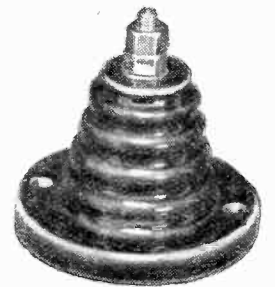

Goltone low loss stand-off insulator.

# READERS' PROBLEMS

## High-output D.C. Set

WE are asked to state the approximate output of the "Wireless World" D.C. Superhet described recently in these pages.

The receiver in question gives more volume than the average D.C. receiver; its undistorted output under average working conditions amounts to about 1.8 watts.

## Manual and Automatic Control

IN order that an A.V.C. system may work at its best, it is just as well that the pre-detector section of the receiver should always operate at maximum sensitivity until a carrier wave sufficiently strong to

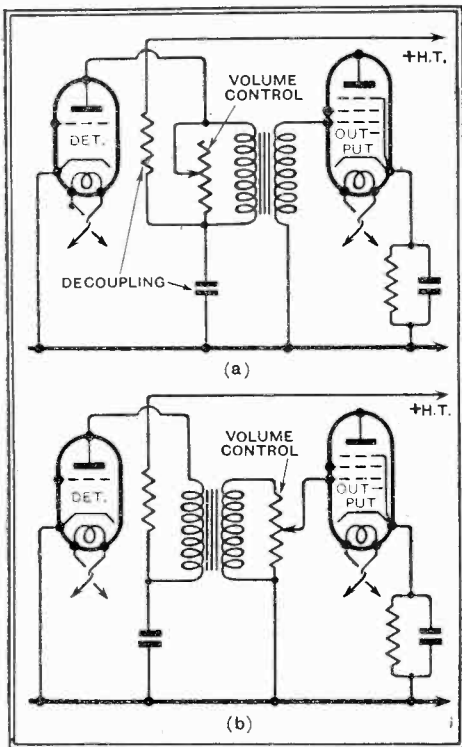

Fig. 1.—Diagram (a) shows the most practical form of L.F. volume control for a transformer-coupled L.F. stage. The other arrangement, suggested by a querist, is not recommended.

de-sensitise it is received. It will therefore be seen that any form of manual volume control which affects the H.F. (and generally the I.F.) amplifier is therefore more or less ruled out.

A reader has confirmed the truth of this statement by experience; although the H.F. manual control which he has fitted works up to a point, it is found to be inconvenient. Accordingly he proposes to fit an L.F. control, and asks whether a high-resistance potentiometer across the L.F. transformer secondary would be satisfactory.

To impose a load on the secondary of any L.F. transformer is distinctly dangerous, and is almost certain to be productive of poor quality. A much better plan would be to connect a variable resistance of 50,000 ohms or so across the primary winding, as shown in Fig. 1 (b).

When dealing with a set such as that used by our correspondent (with a single

transformer-coupled L.F. stage), the addition of post-detection volume control is always something of a problem. When any form of diode detection is employed, however, this difficulty disappears entirely, as the diode load resistance may be in the form of a potentiometer, from which any desired proportion of the total rectified voltage may be picked off for application to the L.F. amplifier.

## Electrostatic Speakers

A GOOD deal of uncertainty seems to exist as to the type of receiver with which an electrostatic loud speaker may be used satisfactorily; some correspondents seem to be under the impression that a highly specialised set is necessary. This is a mistake, and there is no basic reason why any receiver should not be employed with one of these instruments, provided that a polarising voltage of 200 volts or more is available. In practice, of course, it is desirable that the receiver should have a good response in the middle and upper registers.

## A Choice of Positions

WE are asked to give a ruling as to the best position for a band-pass filter in a "straight" receiver with one H.F. stage. The querist who raises this point has noticed that in a number of receivers (including several described constructionally in this journal) the filter is employed as an inter-valve coupling, instead of in the aerial input circuit.

This is a matter about which designers have not yet reached full agreement. Briefly, there is a good deal to be said for retaining the filter in the aerial-grid circuit, where it reduces the possibility of cross modulation or similar forms of interference. In the inter-valve circuit, increased stability, greater freedom from background "hiss," and better ganging, are likely to be obtained, although the latter advantage may disappear when much use is made of reaction.

## Non-Oscillation

CONSTRUCTORS of the New Monodial receiver, who suspect that the oscillator is failing to function at all tuning positions, should make quite sure that the heater of the combined detector-oscillator valve is operating at the recommended work-

.....  
The Wireless World

## INFORMATION BUREAU

THE service is intended primarily for readers meeting with difficulties in the construction, adjustment, operation, or maintenance of wireless receivers described in *The Wireless World*, or those of commercial design which from time to time are reviewed in the pages of *The Wireless World*. Every endeavour will be made to deal with queries on all wireless matters, provided that they are of such a nature that they can be dealt with satisfactorily in a letter.

Communications should be addressed to *The Wireless World* Information Bureau, Dorset House, Stamford Street, London, S.E.1, and must be accompanied by a remittance of 5s. to cover the cost of the service. The enquirer's name and address should be written in block letters at the top of all communications.

THESE columns are reserved for the publication of matter of general interest arising out of problems submitted by our readers. Readers requiring an individual reply to their technical questions by post are referred to "The Wireless World" Information Bureau, of which brief particulars, with the fee charged, are to be found at the foot of this page.

ing voltage. This point is easily checked with the help of a good A.C. voltmeter. Failing a proper measuring instrument, it will almost always be safe to short-circuit two or three turns of the series-connected heater resistance when signs of non-oscillation are present.

## Directional Effects Negligible

OLD fallacies die hard, and the belief is still widely held that the "pick-up" of an aerial is appreciably affected by the direction in which its horizontal span lies.

So far as ordinary broadcast receiver aerials are concerned, the directional effect is negligible. This effect only becomes evident with large aerials, with a length many times greater than their height.

Investigation of several cases where marked directional effects have been noticed has shown that an absence of local screening in one direction only is almost always responsible.

## Grid Decoupling

THE somewhat elaborate system of grid-circuit decoupling employed until recently has now been almost completely superseded by the much simpler expedient of shunting the bias resistance with a dry electrolytic condenser of high capacity but low working voltage. A capacity of between 20 and 50 mfd. is customarily employed for this purpose, and the scheme is, of course, applicable only to true self-biased circuits where the necessary voltage is developed across a resistor inserted in the cathode lead of the valve concerned. This arrangement is shown in Fig. 1 (a).

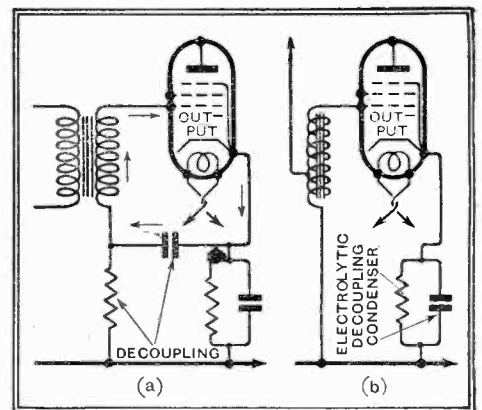

Fig. 2.—The conventional grid decoupling circuit, where signal-frequency energy is restricted to the path indicated by arrows. Diagram (b) shows a simpler and often more effective method.

These remarks are prompted by a letter from a reader who asks us to criticise the circuit diagram of his proposed receiver. Except for the bias circuit, everything is in order, but a resistance-fed autotransformer is to be employed, and so the conventional decoupling scheme proposed would be quite ineffective. Even with other forms of L.F. coupling, the simple high-capacity by-pass condenser is now considered to be best for purposes of decoupling.



# The Wireless World

THE  
PRACTICAL RADIO  
JOURNAL  
23<sup>rd</sup> Year of Publication

No. 741.

FRIDAY, NOVEMBER 10TH, 1933.

VOL. XXXIII. No. 19.

Proprietors: ILIFFE & SONS LTD.

Editor:  
HUGH S. POCOCK.

Editorial,  
Advertising and Publishing Offices:  
DORSET HOUSE, STAMFORD STREET,  
LONDON, S.E.1.

Telephone: Hop 3333 (50 lines).  
Telegrams: "Ethaworld, Watloo, London."

COVENTRY: Hertford Street.

Telegrams: "Cyclist, Coventry." Telephone: 5210 Coventry.

BIRMINGHAM:

Guildhall Buildings, Navigation Street, 2.

Telegrams: "Autopress, Birmingham." Telephone: 2970 Midland (3 lines).

MANCHESTER: 260, Deansgate, 3.

Telegrams: "Iliffe, Manchester." Telephone: Blackfriars 4412 (4 lines).

GLASGOW: 26b, Renfield Street, C.2.

Telegrams: "Iliffe, Glasgow." Telephone: Central 4857.

PUBLISHED WEEKLY. ENTERED AS SECOND  
CLASS MATTER AT NEW YORK, N.Y.

Subscription Rates:

Home, £1 1s. 8d.; Canada, £1 1s. 8d.; other  
countries abroad, £1 3s. 10d. per annum.

*As many of the circuits and apparatus described in these  
pages are covered by patents, readers are advised, before  
making use of them, to satisfy themselves that they would  
not be infringing patents.*

## CONTENTS

	Page
Editorial Comment .. ..	369
The Receiver in Outward Form ..	370
Building a Whistle Filter .. ..	372
The Output Stage .. ..	374
News of the Week .. ..	376
PROGRAMMES FROM	
ABROAD, pp. I—XXIV.	
Broadcast Brevities .. ..	377
Harmonic Distortion .. ..	378
Practical Hints and Tips .. ..	380
Climax Set Review .. ..	381
Letters to the Editor .. ..	382
Laboratory Tests .. ..	383
Readers' Problems .. ..	384

## EDITORIAL COMMENT

### Cabinet Design

#### Housing the Wireless Set

**A**N article in this issue discusses the question of the outward form of the wireless receiver, and the author raises a number of points which should provide food for thought for those who are responsible for the containers for our wireless sets. Our author has, we think, been very restrained in his criticisms of the various methods of tackling this problem as illustrated in examples of current models. The truth is that no satisfying solution to the problem of housing a wireless set has yet been evolved, and here we are not levelling criticism at the efforts of any designer in particular, for all types are unsatisfactory, though a few are better than the rest. Is it reasonable to expect a designer to set out to try to meet public taste when the public is at present divided into at least three distinct classes as regards their views on what a wireless container should be?

First, there are those who consider that a wireless set should not appear in a living room at all; that the speaker should be somewhere cunningly concealed from view and the set preferably installed elsewhere and operated entirely by remote control. Secondly, we have a very large class of wireless user which considers that the set should be camouflaged by accommodating it in some existing example of furniture which harmonises with the period or general style of furnishing of the room in which it is to be used; and, thirdly, there are those who suggest that the set should be a wireless set with its own individuality evolved to meet its own particular function, just as the piano, the harp, the violin, and the clock have been evolved with no attempt at camouflage.

As we have pointed out in recent editorial comment, one of the weakest points in design is the difficulty experienced on nearly every type of set in tuning. There appears to be a conspiracy on the part of designers to make the tuning device as inconspicuous as possible, and nearly always most inconveniently located.

There is so much scope for originality on this question of housing the receiver that we feel it is a matter in which our readers might like to interest themselves by sending to us suggestions or rough sketches of what they would regard as the ideal arrangement. We would suggest that if readers will do this they should first of all try to forget present designs entirely and evolve some original scheme of their own. We would then be prepared to have these sketches properly drawn up and illustrated in a future issue, so that readers could compare their respective efforts and make a further selection from amongst the designs illustrated.

### Television

#### No Great Expectations Yet

**R**UMOURS are still circulating to the effect that the 30-line Baird transmissions now put out by the B.B.C. (mostly at times other than those scheduled in the programmes!) are to cease with the termination of the present contract in the spring. It is also rumoured that these transmissions will be replaced by a vastly superior short-wave television service.

These stories should not be taken too seriously. The short-wave transmissions cannot be expected to give a service at present, and will at first be only experimental. If a television service is to be maintained, it will be by continuing transmissions along existing lines for the present.

# The Receiver in Outward Form

## Can We Improve Upon the Conventional Layout ?

By H. F. SMITH



Photo.: Maurice Beck.

This Kolster-Brandes console cabinet, designed by Betty Joel, expresses modern tendencies in artistic design.

**I**N a recent speech, the Editor of *The Cabinet Maker* expressed the view that the broadcast receiver would, like all other utility articles, eventually assume the most suitable and convenient outward form through a gradual process of evolution. He was probably right, but evolution may be speeded up, and by taking thought it may be ensured that it proceeds along the most promising lines.

Before the public forms a definite preconceived idea as to what a receiver should look like, it would be as well to make sure that the accepted external design is really right. Unless we do so quickly, the time will soon come when any innovation, however good, will be regarded with prejudice and suspicion.

Basically, almost all broadcast sets are the same externally. The outside container is a box of more or less rectangular form, with a large and partially concealed hole for the loud speaker and three or four projecting knobs in front. Boxes for radio-gramophones and consoles are bigger, and are mounted on legs; occasionally the former outfit has the control panel mounted horizontally under the lid.

It must be conceded that the typical radio-gramophone, especially in the smaller sizes, is from many points of view a very unhandy instrument, and there must surely be scope for a designer with entirely unconventional ideas. Most radio-

gramophones are fitted with a highly sensitive receiver chassis, so presumably they are often used for long-distance reception; again, they need fairly critical adjustment, or why should visual tuning indicators so

often be fitted? The user should, therefore, be able to make adjustments in comfort.

To operate many of the "knobs-in-front" radio-gramophones in a standing position, one should really not be much more than four feet nothing in height, otherwise the knobs cannot be reached and the tuning scale cannot be read without stooping. To sit down to the job is equally awkward, as there is no space for one's knees, especially in an easy chair.

### Sitting Down or Standing Up ?

With knobs and tuning scale on top, it is easy enough to operate the set standing up, but, in the writer's experience, everyone prefers to sit down during a distant-reception *séance*—it seems the natural thing to do.

Most table models are also open to criticism on the score of convenience. Seldom are the control knobs at a suitable height, and even if they are, the

position of the user's forearms, with bent wrists and strained arm muscles, is far from comfortable. A great improvement in this respect can be made by mounting the control knobs at the sides of the

*"POSTERITY has done nothing for us; why should we do anything for posterity?" Perhaps so, but it is not pleasant to think that our generation may be held responsible for standardising an external design that may be susceptible to improvement both functionally and artistically.*

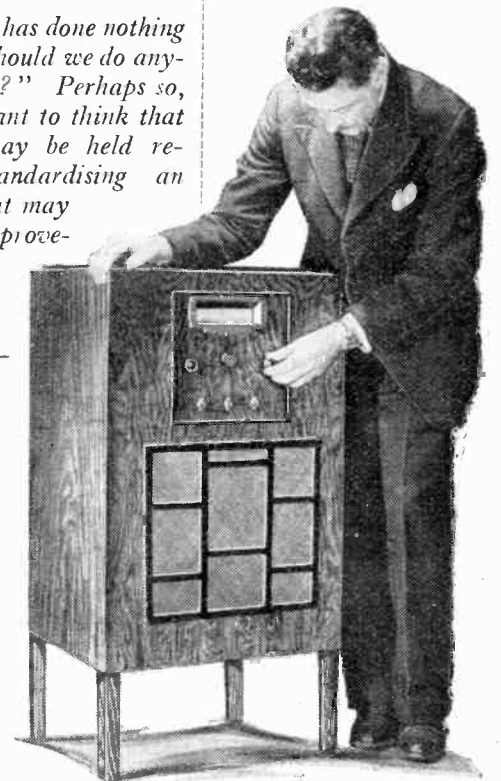

Worse than gardening! This user of a typical radio-gramophone is of average height, but he has to stoop.

A radical departure from convention: the Ferranti chair-side receiver-cum-bookcase is an example of successful originality.



cabinet; with this arrangement one's forearms rest comfortably on the table, there is no wrist-twisting, and the most critical adjustments may be made for long periods without fatigue. Of course, the tuning scale, tuning indicator, and preferably a wave-range indicator, would remain in front. This is not a new idea: side knobs were fitted in early Philips and Regentone receivers, and the tuning control of the Lissen car set is installed in a comparable manner.

### Slaves to Fashion

So far as externals are concerned, most designers seem quite content to follow the example of "the best people," merely expressing their individuality by a symbolical loud speaker fret. The only basically "non-standard" British receiver seems to be the Ferranti "Gloria Companionette," which may be described as an armchair-side receiver, clearly designed to appeal to the type of user who regards his set as a means of relaxation for leisure hours. Without suggesting that the de-



**The Receiver in Outward Form**—sign would suit everyone, it is at least eminently practical and works well. The set is very easy to tune from an armchair of the right height, and, indeed, is the only one that can be so operated in comfort.

It has been suggested editorially in *The Wireless World* that we might often revert to the plan of separating set and speaker. To do so would make it easier to satisfy the public demand for small sets. In America, whence so many of our ideas in radio are supposed to come, this alteration is being seriously considered.

**Engineer and Artist as Partners**

All this has been written from the "functional" point of view, but it is not denied that the set of the future must be pleasing to the eye as well. But the older traditions of ornateness are quite out of keeping with the broadcast receiver, and even the modernist designer can sometimes be every bit as vulgar as his Victorian prototype. The only difference is that he favours meaningless and useless ornamentation of quite a different type. The whole subject is one that calls for close co-operation between the technician and the artistic designer who is in sympathy with modern ideas.

**The Artist-Designer's Point of View**

*In the preceding article, our contributor has concerned himself hardly at all with aesthetic considerations, or the question of design purely from the artistic point of view. From these aspects his conclusions will be supplemented by those of prominent designers of cabinets for well-known radio manufacturers, who have very kindly expressed their views to "The Wireless World."*

FOR the cabinet-work of their new "de luxe" superheterodyne, Kolster-Brandes wisely decided to take an outside opinion; we wireless people are apt to become set in our ideas on what

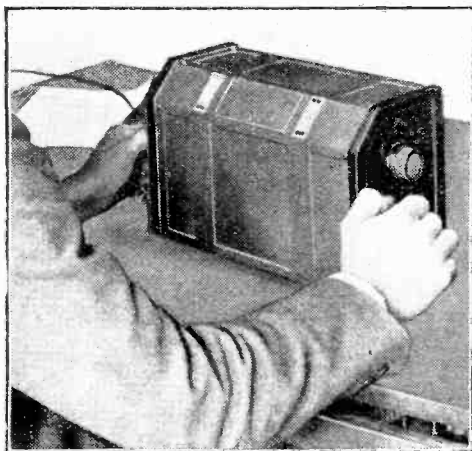

An early type of receiver with side knobs, allowing a natural and comfortable operating position.

we regard as non-essentials. They called upon the services of Betty Joel, who, with her husband, Commander David Joel,

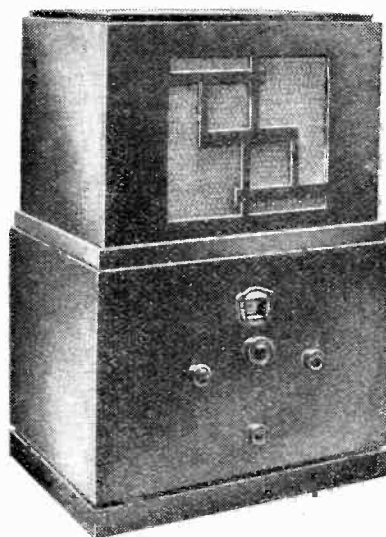

A two-unit C.A.C. receiver: the loud speaker is self-contained, and may be moved to any desired position.

directs the activities of Betty Joel, Ltd., the well-known designers and makers of modern furniture.

It might be expected that her attitude towards the radio art would be mildly antagonistic, or at best that she would regard all mechanical contrivances as necessary evils. But Betty Joel is not at all like the layman's idea of an "arty" person; she is prepared to look upon a beautifully designed machine as an object of delight; certainly nothing to be camouflaged or hidden. No attempts to make the wireless set look like anything else are tolerated, and her ideals are the same for broadcast sets as for furniture.

To achieve beauty by line, form and proportion, and by the natural attractiveness of wood, rather than by ornament.

To try hard to eliminate all non-essentials, and never to put anything into a design just to make it more amusing or different.

Commander Joel's experience of the technical aspects of wireless goes back to the early days of the war, but he prefers not to commit himself on the question of possible basic improvements in outward form. So far, the job has been to devise a cabinet for a receiver of conventional layout, but both he and Mrs. Joel would welcome anything that makes the set of to-morrow more convenient and suitable for its function.

ALTHOUGH Mr. W. N. Duffy, who designs the Ferranti cabinets, is responsible for the solitary British receiver of truly original layout, he does not of necessity think that there is very much wrong with cabinets planned on conventional lines. But large manufacturers should produce a sufficient range of models to cater for varying tastes and needs.

Mr. Duffy is a man of definite and clear-cut ideas; he holds that sets must be functionally as perfect as they can be

made, and he is most emphatic in condemning attempts at disguise.

That the broadcast receiver will eventually become smaller is another of his convictions, but he is willing to admit that, in order to obtain efficiency, coupled with good reproduction and extreme compactness, it may be necessary to separate set and speaker.

In Mr. Duffy's view, there is no more suitable material than wood for radio cabinets, and he admits a personal distaste for the modern horizontal type of container, which, he points out, occupies much more table space than the upright table set.

Finally, he considers that no designer should succumb to the temptation to make a set merely look attractive in the dealer's showroom or on an exhibition stand; he proved very successfully that the designs for which he is responsible gained in attractiveness when they were placed amid ordinary domestic surroundings.

MR. RICHARD RUSSELL is a member of the firm of Gordon Russell, which both designs and manufactures the cabinets for Murphy sets, and has exerted a considerable influence both in the spheres of radio and furniture. His expressed views on the question of broadcast receivers are mainly concerned with the future; being a staunch supporter of built-in furniture (as part of the permanent

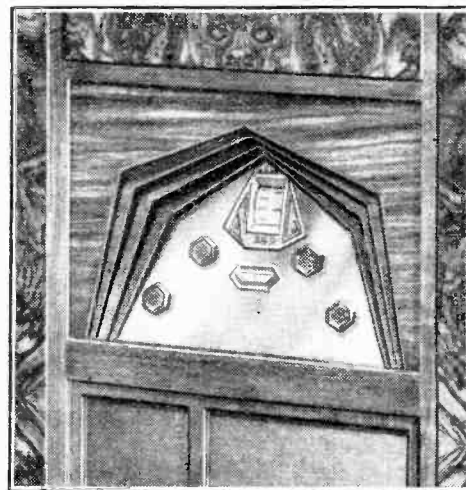

Improving the radio-gramophone. The inclined control panel of R.G.D. sets makes for easier operation.

structure of the house), he thinks that the wireless set will probably be similarly accommodated. Remote control is a possible development, and one that would solve a good many problems.

The awkwardness of the present-day radio-gramophone is admitted, and, so far as the reproduction of records is concerned, he thinks that the best solution of the problem will be afforded by a kind of chair-side playing desk, which might be connected to a more or less distant receiver-amplifier.

Although Mr. Russell is almost solely concerned with wood as a material, he is by no means certain that other substances, even including metal, may not eventually be preferred for cabinet construction.



# Building a Whistle Filter

## Eliminating Heterodyne Whistles and Sideband Splash

By W. T. COCKING

**T**HE only known method of removing heterodyne whistles and sideband splash is by restricting the high frequency response of the receiver. The quality of reproduction thus suffers, but in many cases the net result is preferable to normal quality with a background of whistles, so that the method is not to be despised. It is a common experiment to try connecting a large capacity by-pass condenser across the loud speaker or an L.F. intervalve coupling in order to eliminate whistles, and many sets include a switch whereby such a condenser may be connected in circuit at will. Such an arrangement, however, is not very satisfactory, for if the condenser be large enough to remove the whistle, in most cases the quality of reproduction will suffer greatly.

With such a simple circuit, a large degree of attenuation at the whistle frequency cannot be obtained without severely restricting the amplification of much lower frequencies. Thus, a condenser sufficiently large to remove a whistle even as high as 9,000 cycles will often greatly reduce the response at a frequency as low as 3,000 cycles, while to remove a 5,000 cycles whistle by this means leads to an almost total absence of high frequencies.

The only entirely satisfactory remedy is

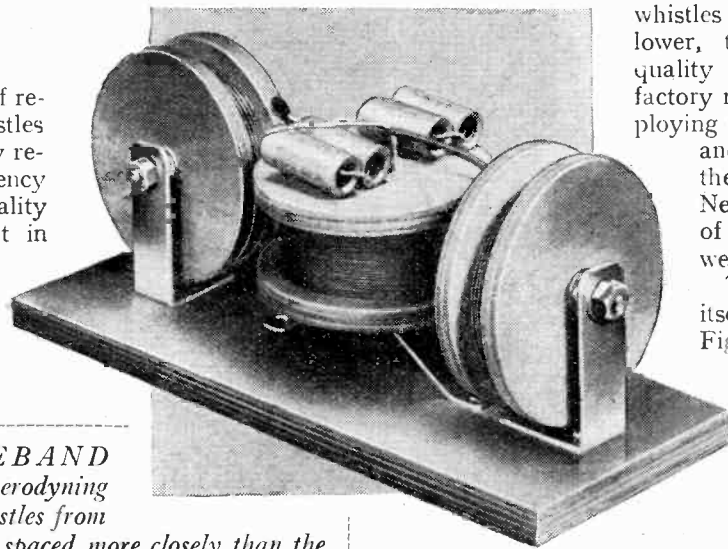

**SIDE BAND** heterodyning and whistles from stations spaced more closely than the standard 9 kc/s are all too common in distant reception. They may readily be eliminated by the use of a filter, however, and a special design is described in this article.

A general view of the filter, showing the arrangement of the parts.

to employ a correctly designed and terminated low-pass filter, and several filter stages are necessary. Experiment has shown that if frequencies up to 3,500 cycles are fully reproduced and all higher frequencies are greatly attenuated, whistles higher in frequency than about 4,500 cycles are inaudible. This meets most practical requirements, since sideband splash normally consists of frequencies above 4,500 cycles, and most steady heterodyne whistles are also above this frequency.

The filter used, however, must cut-off very sharply at 3,500 cycles, otherwise the attenuation at higher frequencies will not suffice. A simple filter, therefore, is unsatisfactory, and it will only eliminate

whistles if the cut-off frequency be made lower, thus unnecessarily harming the quality of reproduction. Entirely satisfactory results have been obtained by employing the filter described in this article, and a similar type was included in the design of *The Wireless World* New Monodial Super<sup>1</sup>, and proved of great aid in the reception of the weaker continental stations.

The circuit diagram of the filter itself is shown by the heavy lines of Fig. 1, and it will be seen to consist of three inductances and four capacities. The connections to the receiver are shown by the shaded portion of the diagram, and will necessarily vary somewhat in different circumstances. The valve preceding the filter should be of a type with an internal resistance of some 10,000 ohms, and in order to preserve correct loading of the filter the load on the output terminals should also be 10,000 ohms. In the case of a transformer coupling, this is easily arranged by shunting the

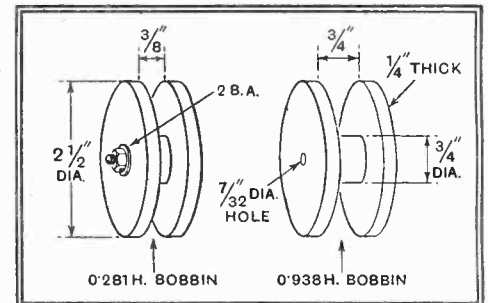

Fig. 2.—The dimensions of the coil bobbins and their construction will be readily apparent. The 0.281 H. coils each have 3,300 turns of 40 D.S.C. wire, while the 0.938 H. coil has 7,000 turns of the same wire.

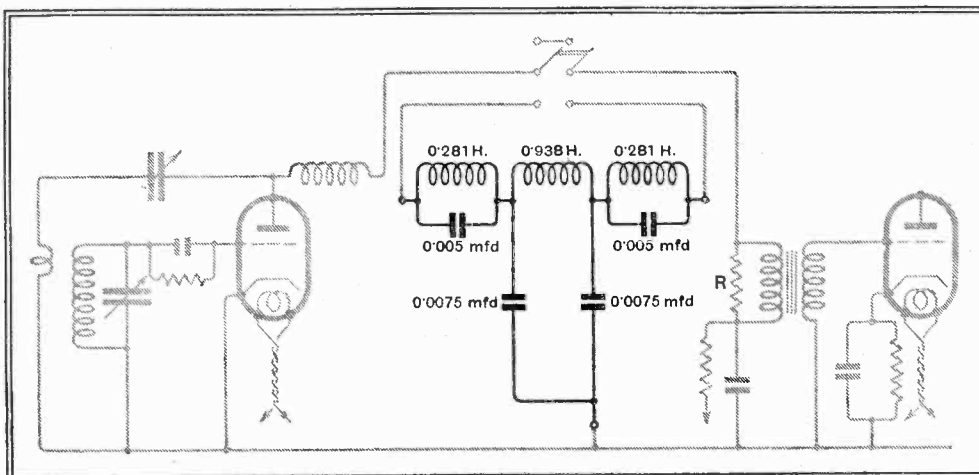

Fig. 1.—The complete circuit diagram of the filter is shown in heavy lines, and the shaded portion of the diagram indicates the connections to a typical receiver, including the use of a switch for cutting it out of circuit when it is not required.

primary with a 10,000 ohms resistance (R), and with a resistance coupling by using a 10,000 ohms coupling resistance.

### Constructing the Coils

The filter has some deleterious effect upon the quality, although this is by no means as much as one would at first expect. It is obviously desirable to be able to cut it out of circuit, therefore, when the station is not suffering from whistle interference, so that the double-pole switch should be included, and connected as shown in Fig. 1. With the switch in the upper position the filter is thrown out of circuit.

The coils themselves can readily be wound by hand, but it is a great saving if a small winding machine can be arranged with a revolution counter. In each case, the core of the former consists of a

<sup>1</sup> *The Wireless World*, July 21st and 28th, 1933.



**Building a Whistle Filter—**

length of  $\frac{3}{4}$  in. dowelling, a material which is readily obtainable. When assembling

line, otherwise the coupling between them will modify the filter characteristics.

It will be noted from Fig. 1 that two condensers of 0.0075 mfd. capacity are needed. This is not a standard capacity, however, so that actually each of these condensers consists of two series connected 0.015 mfd. condensers.

The real test of the filter lies in its ability to remove high-pitched whistles.

It should be noted that if the receiver itself is incapable of reproducing much above 3,500 cycles, the addition of the filter will not appreciably affect the results, for the high frequency whistles will have been already removed. With selective sets, the presence of sideband splash is a good test of the high note response; if such interference be found, therefore, it may be taken that the use of the filter will permit the removal not only of the sideband splash itself but also of some of the steady heterodyne whistles.

A further use for the filter lies in reducing needle scratch in the electrical reproduction of gramophone records, for most of the scratch frequencies lie above 3,500 cycles. The connections for this, of course, are identical with those for a whistle filter, and if the receiver be arranged in the usual way for the addition of the pick-up to the detector valve the filter will automatically

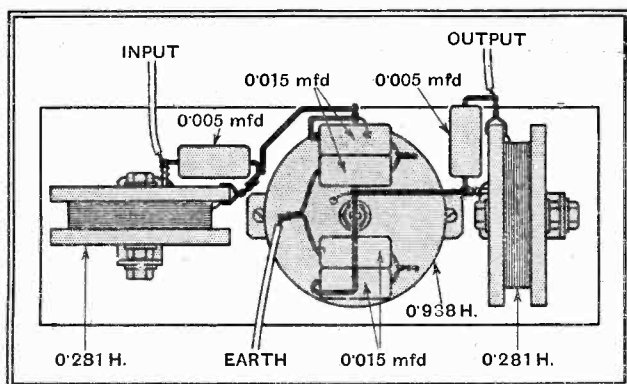

The wiring plan of the low-pass filter. It should be noted that pairs of 0.015  $\mu$ F condensers are connected in series to produce capacities of 0.0075  $\mu$ F.

the formers, the dimensions of which are given in Fig. 2, care should be taken to see that the cheeks fit flush with the ends of the core so that the first turns of wire do not slip between the cheeks and core.

The two smaller formers are used for the 0.281H. coils, and each must be wound with 3,300 turns of No. 40 D.S.C. wire; in order to avoid breaks where the wire is led out, it is a wise plan to solder a length of heavier wire, say, No. 32 gauge, to the No. 40 and wind the first few turns with this. The 0.938H. choke is wound on the larger former, and requires 7,000 turns of the same wire.

**The Coil Mounting**

The method of mounting the coils will be seen in the photograph of the complete filter. Small aluminium brackets serve to hold the coils in place, and care should be taken to mount them at right angles to one another with their centres in

tion, however, it is better to omit the H.F. choke in the detector anode circuit can be left in place, and if the set be fitted with reaction this is necessary on account of the filter. If the receiver be one without reaction, however, it is better to omit the H.F. choke and to join the detector anode directly to the input terminal of the filter; the usual anode-cathode by-pass condenser should also be removed, for the input capacity of the filter at high frequencies is sufficient to take its place.

When testing, it may be found at first that little difference in the quality of reproduction is discernible, whether the filter be in circuit or not. This should not necessarily be taken as a sign that the filter is not functioning correctly, for the restriction of the high-frequency response is not so much noticeable as a loss of high notes as in a change in the tone of certain musical instruments.

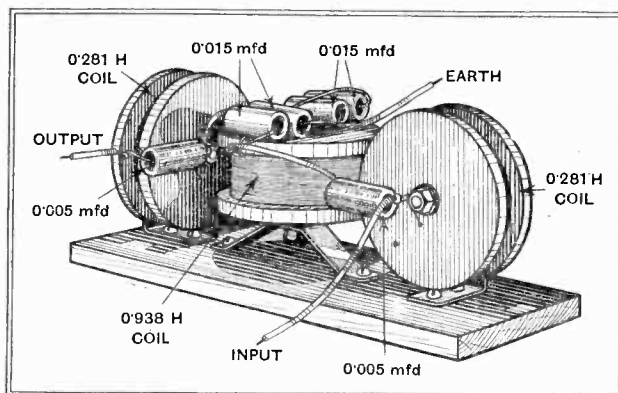

The general construction of the filter can be seen from this drawing, together with much of the wiring.

change its function from a whistle suppressor to a scratch filter when the gramophone pick-up is brought into action.

**DISTANT RECEPTION NOTES**

**Those Finnish Stations : The Harmonics Problem**

A CORRESPONDENT writing from Helsinki asks why I never refer in these notes to the Finnish transmitters. "We have," he says, "three high-powered transmitters, and I should think that Lahti, at any rate, ought to be heard in England." None of the Finnish transmitters is at all regularly heard in this country. I have occasionally received Lahti, but even on a big superheterodyne signal strength has never been better than moderate. Viipuri I logged once a year or two ago, but I have not heard the station since, and Helsinki has never made an appearance in my log.

The Kootwijk transmitter, which takes over the Huizen service from 3.40 p.m. onwards, is gaining notoriety as a prize generator of harmonics. The last published report of the Brussels Laboratory of the U.I.R. shows that no fewer than four occur regularly and are definitely identified. These are the fourth, which heterodynes Langenberg and Lyons Doua at times; the fifth, just below the Scottish Regional; the sixth, almost on top of Cracow and Genoa; and the eighth, close to Lodz. The seventh harmonic also probably occurs, but this falls on 267.8 metres, where there is already such

a hopeless jam that identification is virtually impossible.

As I have hinted previously, the problem of harmonics, particularly from the long-wave stations, may assume considerable importance when the Lucerne Plan comes into operation. Matters may be brought to a head when Daventry, Zeesen, and other stations increase their power.

**High Power from France**

Radio-Paris is amongst the long-wave stations whose power will be increased to 150 kilowatts in the not-far-distant future. At a recent dinner of the French Association of Wireless Manufacturers M. Eynac, who was then Minister of Posts and Telegraphs, announced this fact. He stated, also, that the PTT stations built or building under the General Ferrié Plan at Toulouse, Lyons, Marseilles, Nice, Rennes, and Lille would all be completed and transmitting at high power before the end of next year.

Transatlantic reception continues to be wonderfully good in the early mornings, and now that sunrise is becoming so much later more and more reports of "before break-

fast" reception will probably come in. Many of the bigger American stations do not close down until 2 a.m. Eastern Standard Time, which is 7.30 a.m. by ours, and not infrequently they are to be found at work an hour or more later than this.

A certain amount of improvement in the matter of heterodyne interference is noticeable at present. The whistle accompanying Luxembourg is often hardly noticeable, and Kalundborg is coming in quite free from interference as a rule.

Interference with Kootwijk's transmissions of the Huizen programmes has not been noticeable for some days prior to the time of writing and good reception has been the rule. Zeesen, Motala, and Oslo have all provided excellent reception on the long waves. Oslo, though good as a rule, is sometimes heterodyned.

Both Vienna and Budapest are well heard; in fact, transmissions coming in at full loud speaker strength are to be picked up now at almost every division of the tuning dial between 465 and 550 metres.

In the remainder of the medium wave-band, Rome, Stockholm, Katowice, Toulouse, Leipzig, Strasbourg, Brussels No. 2, Poste Parisien, Hilversum, Turin, Nürnberg and Fécamp are outstanding. And there are at least a dozen other stations that are generally well received. D. EXER.

# The Output Stage

## Obtaining Maximum Volume Without Distortion

By S. O. PEARSON, B.Sc., A.M.I.E.E.

**T**HE output stage, which comprises the last valve in a receiver, with its associated circuits, is essentially different from any other valve stage. This article explains, in the simplest possible terms, the necessity for reasonably accurate matching between valve and loud speaker.

**T**HE output valve acts in a totally different capacity from any of the other valves in a wireless receiver, its function being to cause the greatest amount of power to be delivered to the loud speaker with a given signal voltage applied to the grid. Output valves are accordingly designed with this end in view, and take the form of either power valves (triodes) or pentodes, and special measures have to be taken to match the speaker impedance to the A.C. resistance of the valve. The necessary power-handling capacity of the valve depends on the maximum undistorted output required, this in turn being determined by the volume desired and the sensitivity of the loud speaker in use.

The loud speaker, of course, comprises the "load" or external impedance in the anode circuit of the power valve, whether the speaker be connected directly in the anode circuit or indirectly through the medium of usual output transformer or choke-filter circuit. Whichever system is employed, it can be resolved into the electrical equivalent of an impedance  $Z$  connected directly in the anode circuit of the valve as in Fig. 1.

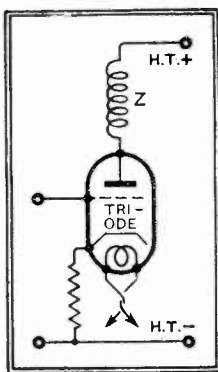

Fig. 1.—In an output stage, the loud speaker acts as an impedance in the anode circuit.

When a signal voltage is applied to the grid, current variations are set up in the speaker coil and operate the cone or diaphragm. It is only the alternating component of the anode current which is effective in operating the loud speaker, the steady anode current being only a necessary evil. It must be remembered that the power, or energy, does not come from the valve at all, but from the source of H.T. supply, and that the power valve acts merely as the means of controlling both total power consumed and the A.C. power delivered to the speaker.

### Matching the Speaker Impedance

To obtain maximum power input to the speaker with a given applied grid-voltage

variation, the effective impedance of the speaker must bear a definite relationship to the A.C. resistance of the valve itself under operating conditions. Unfortunately, it is impossible to calculate the best

value of impedance with mathematical accuracy, for two main reasons. In the first place the impedance is a function of the frequency, a rise in frequency usually being associated with a rise in impedance, and so, as the speaker has to operate over the whole range of musical frequencies, the matching must be effected at about the middle of the range, usually at or near the frequency corresponding to middle C of the musical scale. Secondly, at a given frequency, the power delivered to a given impedance

in the anode circuit depends on the composition of this impedance, that is to say, on the relative values of resistance and reactance comprising the impedance. It is a well-known principle in A.C. circuits that the average power absorbed is less than the product of R.M.S. amps. and volt. A power factor has to be employed, and in an inductive circuit this is always less than unity. In a circuit with all reactance and no resistance the power factor is zero and no power is absorbed.

### For Maximum Power

To simplify matters, let it be supposed in the first place that the speaker impedance in the anode circuit comprises a pure resistance  $R$ . Then it can be shown quite simply that the maximum A.C. power is developed in this resistance when it is made exactly equal to the A.C. resistance of the valve. For instance, suppose that the A.C. resistance of the valve is 1,000 ohms and that the alternating voltage at

the grid causes, in effect, an E.M.F. of 20 volts to be set up in the anode circuit. If the load impedance is made equal to 1,000 ohms, the total resistance of the circuit is 2,000 ohms and the current, found by Ohm's Law, is 10 milliamps. The power in the external resistance is therefore  $I^2R = 100$  milliwatts. Now, making the load resistance any other value, say, 500 ohms, the total resistance is 1,500 ohms and the current 13.3 milliamps. The power in  $R$  is then  $I^2R = 88.8$  milliwatts, which is less than before.

Similarly for any other value of external resistance the power would be found to be less than 100 milliwatts.

If, then, the loud speaker could be considered as a pure resistance, maximum output would be obtained by choosing a value equal to the valve resistance. But the presence of reactance upsets this condition, and since the reactance varies with frequency a compromise must be struck. In practice it has been found generally satisfactory to make the effective speaker impedance at the middle frequency about twice the

A.C. resistance of the valve. The frequency characteristics of most loud speakers are such that a fairly good balance between upper and lower frequencies is attained with this ratio of effective speaker impedance to valve resistance.

### Use of an Output Transformer

It often happens that a particular loud speaker is required to be operated by an output valve whose A.C. resistance is not suited to the impedance of the speaker. In fact, most speakers are wound with very low impedance coils and cannot be directly operated by any valve. In such cases an output transformer is used, being of the ordinary two-circuit type and connected as shown in Fig. 2 (a), or of the auto type, or tapped choke, being connected as in Fig. 2 (b).

By a suitable choice of the ratio of primary to secondary turns the widely differing impedances of the speaker and valve can be effectively matched. If  $N$

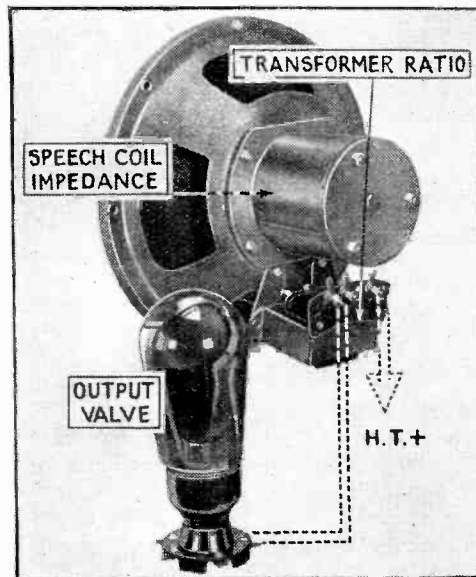

Factors to be taken into account in matching a loud speaker to the output valve.



**The Output Stage.—**

is the ratio of primary to secondary turns of the transformer, a load impedance of  $Z$  ohms across the secondary terminals is equivalent, in its effect, to an impedance

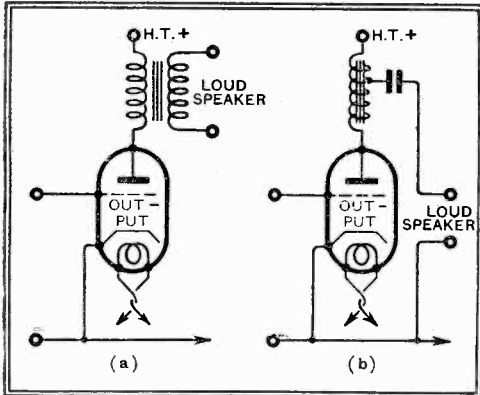

Fig. 2.—Either a double-wound transformer (a) or a tapped choke or auto-transformer (b) may be used for matching the loud speaker to the output valve.

of  $N^2Z$  ohms in the primary circuit. Now for the *effective* load impedance in the anode circuit of the valve to be twice the A.C. resistance  $R_a$  of the valve,  $N^2Z$  must be equal to  $2R_a$ . So, in words, the turns ratio of the output transformer must be equal to the square root of the ratio of twice the valve resistance to the speaker impedance ( $N = \sqrt{2R_a/Z}$ ).

In the case of an auto-transformer or tapped choke,  $N$  is the ratio of the total turns to those between the tapping and the upper or H.T. supply end.

When the speaker impedance and valve resistance have been suitably matched to give the best balance between the upper and lower frequencies in the response, the maximum possible power that can be delivered to the speaker without introducing noticeable valve distortion depends on the design of the valve itself and on the value of H.T. employed. The pentode output valve is in a class by itself and must be dealt with separately. In the case of an ordinary power valve or triode the A.C. resistance is made as low as possible compatible with a reasonably high mutual conductance. Of the total energy drawn from the H.T. supply by the power valve, only a fraction of about one-fifth can normally be delivered to the speaker, the remainder being dissipated at the anode. So, in general, an output valve requires a moderately high anode current. And, further, since the available power, with a given anode current, is proportional to the H.T. voltage, the valve should be operated at the maximum H.T. voltage specified by the makers.

**In Next Week's Issue—**

Special Articles for the  
**RADIO-GRAMOPHONE  
ENTHUSIAST.**

Pick-up Circuits, Tone Control  
Units and Gramophone Accessories.

# Television Explained

## III.—The Problem of Synchronisation

IT might be thought that satisfactory synchronisation of the Nipkow discs at the transmitter and receiver could be obtained by the simple process of using identical motors and adjusting them to run at the same speed, by controlling the receiver motor by means of a variable resistance or some similar device. It might be thought also that the mechanism of a clock could be pressed into service, for it is one of the most accurate pieces of mechanism in common use. One which gains or loses a minute a week is considered to be only a fair timekeeper, and yet this represents an accuracy of 0.0154 per cent. The degree of accuracy necessary in the synchronisation of the discs for television purposes may perhaps be realised when it is remembered that it corresponds to a clock which gains or loses no more than one second in several months.

Where  $12\frac{1}{2}$  pictures are transmitted a second, and there are 30 lines to a picture, the disc must rotate 750 times a minute. Many methods of synchronisation have been proposed, but that now used in the B.B.C. transmissions is quite simple. The transmitted picture is arranged to have a black strip along the top, with the result that at the beginning of each scanning line there is a sudden pulse of current in the photo-cell circuit, and this leads to a similar black strip along the top of the received picture. One pulse of current per line means 375 pulses a second, and by means of suitable filters they can be picked out of the picture currents proper and applied to a motor on the shaft of the receiving disc. The power available, of course, is quite insufficient to drive the disc, so that this is run by an electric motor, the speed of which is regulated by the synchronising impulses.

### The Synchronising Impulses

This is carried out by an arrangement such as a phonic wheel, which is really a miniature electric motor mounted on the same shaft as the main driving motor. The phonic wheel, or similar device, is fed by the 375 cycles synchronising impulses, and receives one impulse at the start of every scanning line. If the driving motor is running too quickly the synchronising impulses are received by the controlling motor too late, and it exercises a braking effect upon the disc and retards its speed. If the motor is running too slowly an accelerating effect is produced. The result is that within limits the 375 cycles pulses maintain the transmitter and receiver discs in isochronism, that is, they run at exactly the same speed.

Although they may run at the same speed, they are not necessary in synchronism, for this involves a question of phase.

*THE problems of synchronising are briefly discussed in this article, and the high degree of accuracy required is emphasised. Normally the synchronising impulses in the transmission serve to provide isochronism only.*

The discs are in isochronism if they are running at the same speed, but if one be displaced relatively to the other in an angular direction they are not in synchronism. Exact synchronism is only obtained when the discs are running at the same speed and their holes are in identical rela-

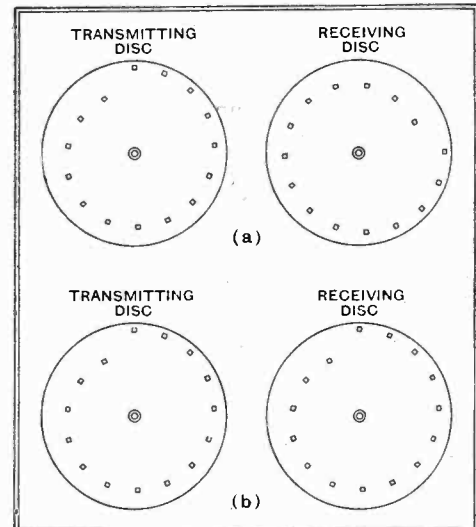

Fig. 1. When both transmitter and receiver discs are rotating at the same speed, synchronism is obtained although the holes may not be in the same relative positions. Isochronism requires that the hole positions be in the same positions as in the left hand drawing.

tive positions at all times. Thus, in Fig. 1 the two discs at (a) are in isochronism when they are running at the same speed, but, since the holes are not in the same relative positions, they are not in synchronism. True synchronism is shown at (b), where at every instant the holes in the receiving disc correspond exactly with those in the transmitting disc.

In practice, true synchronising is obtained by trial and error. The synchronising impulses enable isochronism to be readily established, and the picture can then be seen, even if the holes in the discs do not correspond. Unless perfect synchronisation is obtained, however, the picture will be divided with the left-hand half on the right-hand side of the screen, and vice versa. It is a simple matter, therefore, to retard the motor momentarily until it is in exact synchronisation.

# NEWS of the WEEK

## Current Events in Brief Review

### Faux Pas

RESTORATIVES are being applied to a French author who absent-mindedly gave a tip of 75 centimes to the official who collected his radio licence fee.

### "S.B." Expert Resigns

THE resignation of Mr. George F. McClelland from the Vice-Presidency of the American National Broadcasting Company deprives that company of its pioneer executive organiser, says our Washington correspondent. Mr. McClelland directed the first transcontinental "hook-ups" before the N.B.C. was founded in November, 1926.

### More Power by Day ?

THE American Federal Radio Commission is considering the suggestion that all broadcasting stations should be allowed to increase their power during daylight hours when range is admittedly less than at night.

The outcome of the discussion will be awaited with interest by the European International Broadcasting Union.

### The Old Topic

HAVING been accused of causing wet weather, wireless is now charged with producing droughts. Writing in the *Notting-*

### A Present from Poland

A LARGE number of listeners all over the country tuned in the English talk given by Mr. Thad Ordon from Warsaw on Saturday last, and, as notified in *The Wireless World*, were able to claim the gift of an attractively illustrated book dealing with Poland and its history. Mr. Ordon's talk came through at good strength, and we understand that it was the fore-runner of a number on various topics of interest to British listeners.

### R.A.F. Radio Dinner

A REUNION dinner of officers of the R.A.F. Electrical and Wireless School is to be held at the Royal Air Force Club, 128, Piccadilly, London, W.1, on Saturday, November 25th, 1933. Particulars are obtainable from the Hon. Secretary, Mr. J. F. Herd, Ditton Corner, Datchet, Slough.

### Ferranti Wins Trophy

WE congratulate Messrs. Ferranti, Ltd., on being awarded first place as the result of the ballot organised by the Wireless Retailers' Association in conjunction with Allied Newspapers for the "best-value-for-money" set shown at the Manchester Radio Exhibition. The winning instrument was a Ferranti Lancastrina Parva five-valve Superheterodyne. Ferranti, Ltd., have won the trophy for the second successive year.

### Cinema Exhibition

ALL interested in cinema work, both amateur and professional, and in sound recording on film will be attracted by the Cinema Exhibition to be held in the Dorland Hall, 18-20, Regent Street, London, S.W.1, from November 27th to December 9th. All the latest standard and sub-standard home and industrial ciné equipment will be demonstrated, together with sound-recording and re-recording systems, film developing and printing plants. Educational, cultural and publicity films will be shown in a public studio, and a feature will be the filming of visitors, the results to be shown later in one of the many demonstration theatres.

The "behind-the-scenes" model film-recording studio, complete with camera and recording equipment, should merit special attention. The Exhibition will be open daily from 10 a.m. to 10 p.m.

### Cross-Channel Micro Waves

IN about a week's time the new "micro-wave" wireless stations at Lympne and St. Inglevert aerodromes will be opened for regular communication between London and Paris on a wavelength between 17 and 19 centimetres. The stations are to be used for regular transmission by teleprinter and as an additional safety arrangement for cross-

Channel flights. The transmitter power will be only 500 watts.

The highly concentrated beam will, of course, avoid any interference with other wireless services. Communication with the land lines of Lympne and St. Inglevert will be entirely automatic.

### Medium Waves Across the Atlantic

THE extremely favourable conditions for transatlantic reception at the moment, to which reference has frequently been made by "D. Exer" in Distant Reception Notes, is the subject of a letter we have received from Mr. W. J. Atterton, of Mottingham, London, S.E.9.

"During the last few days," he writes, "such stations as WNAC (Boston) and WCAU (Philadelphia) have been heard as early as 10 p.m."

"Paul Whiteman's orchestra was heard on October 27th on a wavelength of 266 metres at 3 a.m. It is not necessary to get up at this very early hour because an American station has been received very well up to 6.30 a.m. on 348 metres (approximately), the programme consisting of late dance music from the Hotel Atlantic City, New York."

Our correspondent's set is a 1932 Pye superheterodyne receiver Type S1, not fitted with A.V.C.

### A New Inspector

IT has been left to our French contemporary, *L'Antenne*, to discover an official "inspector of aerials" whose existence had hitherto been unsuspected. Our contemporary assures its readers that it has discovered this "Vérificateur des Antennes" in the Government pay rolls. The official journal, from which the news has been gleaned, does not specify the class of aerial inspected. "But the job exists," says our contemporary, "and that is the essential."

### "THE WIRELESS ENGINEER" Special Articles in the November issue.

- A NEW HIGH EFFICIENCY CATHODE-RAY TUBE. Applications as a Projecting Oscillograph,
- CIVIL AVIATION SIGNAL SERVICES. Considerations Affecting the Choice of Wavelengths.
- A MULTI-RANGE DIRECT-READING OHMMETER.

### MODIFICATIONS IN A NEW IMPEDANCE MEASURING SET.

### THE TILT OF RADIO WAVES AND THEIR PENETRATION INTO THE EARTH.

Copies are now on sale, price 2/6, or post free from the Publisher, 2/8.

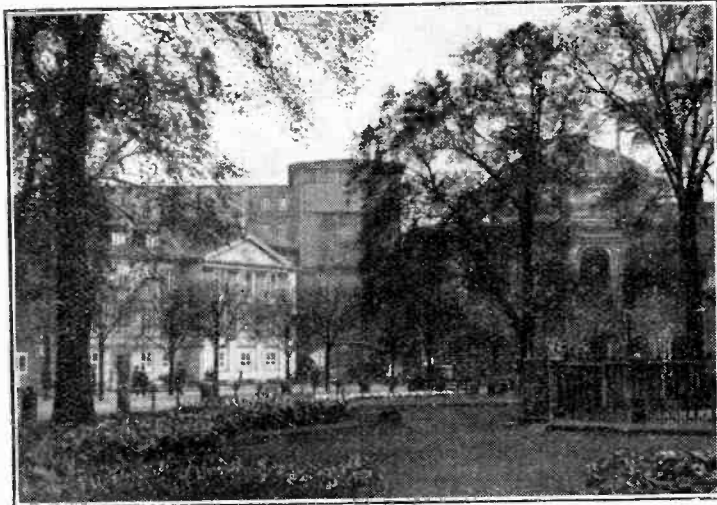

DENMARK'S BROADCASTING CENTRE.—A picturesque view in Copenhagen showing the Danish State "Broadcasting House" on the left. A concert of French opera and ballet music will be broadcast from here on Sunday afternoon. In the right background is the Royal Opera House, from which many performances are relayed.

### Blind Justice

LOUD speakers and micro-phones assisted the judges to impartial decisions during the recent annual Eisteddfod at Sion Church, Caerau. Artistes rendered their items in the vestry which adjoins the main hall, in which the adjudicators appraised the value of each performance without knowing which artiste was performing.

### Will Fécamp Shut Down ?

DESPITE rumours of the forthcoming closure of Radio Normandy, Fécamp, our Paris correspondent assures us that the station's "immediate suppression" is not yet on the cards. Fécamp has merely received formal notification that the power must not be increased above the authorised output of 700 watts. In other words, it appears that there will be no change for the time being.

If the future of Fécamp is precarious, so is that of all the other private stations in France with the exception of Radio Toulouse, which is believed to have a real chance of survival, and of Poste Parisien, which, although it may disappear as a private station, will probably be absorbed into the State transmission scheme.

ham Evening News, a correspondent says: "Through all the ages the clouds have been spread over the heavens and have given us rain arriving true to season; but since the advent of wireless, and the continuous flow of the high-tension vibrations through the ether, the clouds have become grouped, and instead of long periods of seasonal rain, we get 'out-of-season' deluges and long spells of dry weather."

However, he states that it will be the flat, tropical countries that will be the first to be uninhabitable from this cause. This is comforting to those of us in the temperate zone.

### Circuits in Morse

THE remarkable feat of transmitting four complicated circuit diagrams from New Zealand to England has just been accomplished. An amateur in Dunedin gave a point-to-point description of these diagrams to a colleague in South London, accompanying it with a technical article over 1,000 words in length. Short-wave morse transmission was used, diagrams and article being thus morsed 11,000 miles for ultimate reproduction in the "T. & R. Bulletin," the official organ of the Radio Society of Great Britain.



# Broadcast Brevities

By Our Special Correspondent

## What a Birthday!

IF those directing the broadcasting programmes in November, 1922, could have looked forward eleven years to November 14th, 1933, I doubt whether they would have been thrilled. The nature study talk on "Winter Moths and Wingless Females" seems to be quite the most exciting item in the Regional programme for that day. Why have the B.B.C. abandoned birthday celebrations? This is the first year they have been omitted.

## Miserable Comforters

THE Press generally has been adopting a tone of fatherly reassurance apropos the Lucerne Plan, but I fail to see why. Is it to be expected that there will be no trouble whatever on January 15th when 150 stations not only change their wavelengths, but in many cases share new waves with other transmitters?

## I Ask You

If perfect peace and good will were expected the B.B.C. would not be preparing a special pamphlet on the Lucerne Plan for the guidance and comfort of listeners, nor would the engineers be shaking their heads and talking about the possibility of things "settling down" in a few weeks.

Would they, now?

## Relay Whispers

ABERDEEN may borrow an exclusive wavelength from another country.

Newcastle is to operate on 209.9 metres until the new North-Eastern transmitter is erected and takes a higher wavelength.

Bournemouth and Plymouth are each to have new transmitters in the near future, and will then work in synchrony on 203.5 metres.

## Does Radio Cause Corns?

EVERY day there is a corn in Broadcasting House which is a source of somewhat sad pride to its owner, Eric Maschwitz. Situated on the middle finger of the right hand, it has been brought about by toil in the wee sma' hours with a fountain pen and stacks of writing paper.

Maschwitz writes everything by hand.

## Hard Work

The adaptation of "A Waltz Dream," which provided a delightful broadcast on Tuesday last under the direction of Maschwitz, covered more than a hundred sheets of MS., all in its adaptor's own writing.

## A Light in the Window

He is, I believe, the only man who works all day and nearly all night at Broadcasting House. The light in his office can be seen until 4 a.m. or later (charwomen rush in furtively at odd moments to clear the W.P.B.). Just about 4 o'clock he rushes downstairs to the all night buffet and orders a malted milk.

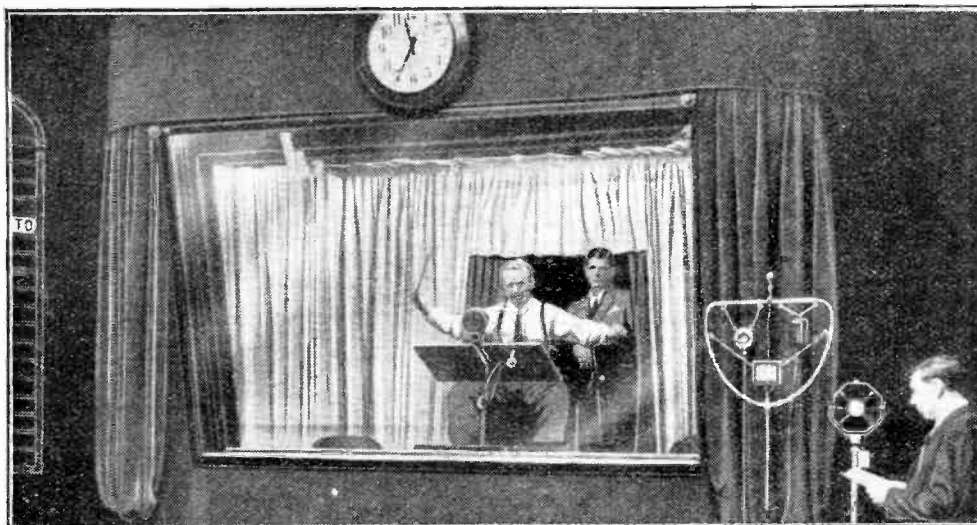

CONDUCTOR AS "LISTENER." Budapest remains the only station in Europe at which the orchestral conductor hears the music just as it comes to the listener on a good set. He is here seen in his sound-proof cabinet. A portion of the silent indicator can be seen on the left

## Home, Sweet Home

Home he then goes to get ready to go to the office, and is back again in Portland Place at ten-thirtyish for rehearsals.

This sort of thing has gone on for four months already. And they call him Director of *Variety*.

## All the Tit-bits

A NEW feature of the Saturday night programme starts on November 18th. Entitled "In Town To-night," it will aim to give listeners up-to-the-minute items concerning what is going on in London. Interviews with and broadcasts by notable personages who have only just arrived in town, or who are in the public eye at the moment, tit-bits from new stage performances, new songs, surprise broadcasts, and other material outside the published programme will be included. The "Diversions" of 1930 revived and elaborated.

## Broadcasting on the Screen

AT last broadcasting is to be featured on the film screen, and all credit goes to the British Lion Corporation for taking the initiative. Roy Fox and his Band, known to millions of listeners all over the world, are now being filmed at the Beaconsfield studios in the radio musical production "On The Air." Other well-known radio stars in the caste are: Betty Astell, Davy Burnaby, Reginald Purdell, James Carr, Mario de Pietro, Hugh E. Wright, and Evé Beck.

## The Announcers' Journal

MRS. BORRETT will leave a memento of her announcing work in the shape of her handwriting in the Announcers' Journal. This interesting diary of broadcasting is kept up hour by hour by the announcers on duty, and some of the entries are as dramatic as they are amusing.

Fainting artistes, mice under the couches, tottering microphones—all these and other phenomena are duly chronicled.

## Fun on the Eighth Floor

Strangely enough, the Engineers' Log Book occasionally contains funny items. At 21.40 on 2/10/33 the engineer on duty wrote: "Provincial stations complain of 'dirty background' to weather and second news. This was due to announcer's shirt-front."

## On Armistice Day

THE service at the Cenotaph on Armistice Day will this year, for the first time, be broadcast simultaneously to all parts of the Empire. The listener in Vancouver will hear the transmission at 3 a.m., whereas in various parts of Australasia it will be heard at any time between 7 and 10.30 p.m.

The broadcast will start at 10.30 a.m. (G.M.T.), when the Bands of the Grenadier, Coldstream, Irish and Welsh Guards will play such selections as "Hearts of Oak," "The Minstrel Boy," "Land of the Leal," "Skye Boat Song," "When I am Laid in Earth" (Purcell), "Flowers of the Forest," and Chopin's Funeral March.

## The Next Big Play

"RED Tabs," the next in the series of great plays in the Radio Drama Festival, is to be heard on December 1st (National) and December 2nd (Regional). This play was written by Val Gielgud, Drama Director of the B.B.C., and first broadcast in October, 1930. It must be unique in post-war literature as a detached discussion of an ethical problem of warfare. The situation faced by General Gore in the play is personal not to him alone, but to every commander of every age from Thermopylae to Ypres. "Red Tabs" is a brief play, clearly argued and free from complications.

## Crisp Criticism

"FOR my sins the other night, I listened in to one of the B.B.C. variety performances. Really! Really!"—*Church Times*.

## Honour for Stoke

THE Post Office Direction Finding Van will be "at home" in the Stoke district during the next few days, and I am told by those who should know that it will then proceed to make life interesting to the more economically minded listeners at Stafford, Shrewsbury, Oswestry, and Chester.

The investigations will finish up on the first Saturday night in December.

## Footnote

PADEREWSKI, the world famous pianist, has agreed to broadcast over the American networks for half an hour for a fee of £2,000.

# Harmonic Distortion

## A Simple Explanation

By D. A. BELL

*WHY distortion is expressed in terms of harmonics, and why amplifiers sometimes give rise mainly to second harmonics, but in other cases produce third harmonics, is fully explained.*

**T**HE production of harmonics by an amplifying valve whose characteristic is not strictly linear is such a familiar idea that we rarely stop to ask how these harmonics are produced or how their magnitude may be estimated. The phenomenon may be most easily understood by comparing the wave-forms resulting from certain combinations of harmonics with the distorted wave-forms produced from a simple sine wave by various curved characteristics.

### Triodes

Suppose, for example, that we have a fundamental and 5 per cent. of second harmonic with the relative phases shown in Fig. 1. If we take the peak amplitude of the fundamental as 100, the resultant of the fundamental and 5 per cent. of second harmonic will be 95 at A, where they are exactly out of phase, but at the positive peak B, where they are in phase, the amplitude will be 105. Thus 5 per cent. of second harmonic corresponds to a wave which has been distorted so that the amplitudes of its two halves are in the ratio of 105 to 95, or approximately 10 to 9. This gives the rule that for 5 per cent. second harmonics the two valves of the load-line (plotted on the anode current — anode volts diagram) are in the ratio of 10 to 9, for the distances from the operating point of the two ends of the load-line represent the amplitudes of the two peaks on maximum input.

In separating the alternating currents from the direct currents in any circuit, an alternating current can be defined as one whose mean value over a whole cycle is zero, since it is alternately positive and negative. All the alternating currents of Fig. 1, therefore, have the same zero line as the fundamental. But the output

must be zero whenever the input is zero, and this occurs when the fundamental, which constitutes the whole of the input, crosses the zero line. Since the second harmonic is at its maximum at these points, the only way to satisfy the condition without disturbing the A.C. components is to add a D.C. component, represented by the dotted line in Fig. 1, which will reduce the resultant to zero at the points X, Y, Z. We therefore say that the output consists of fundamental, second harmonic and a D.C. component. This latter can be observed on a milliammeter as an increase in anode current, and is thus used as a test for distortion.

Since a certain amount of direct current has incidentally been produced from an alternating input, this distortion is sometimes called rectification, and it is interesting as a demonstration that any unsymmetrical characteristic must rectify to some extent.

Another consideration is the effect of distortion on the power efficiency of the valve. Since power is proportional to the square of either voltage or current, and the input must be sufficient to swing up to the larger peak, we take the input power as proportional to  $105^2$ , while the output power is  $100^2$  of fundamental and  $5^2$  of second harmonic. In the absence of distortion the output would be  $105^2$ , so that the loss of total power is  $105^2 - (100^2 + 5^2)$ , which

represents 8.86 per cent. In this case the lost power might be thought to be accounted for by the D.C. component, which is of no use in the loud speaker or other load, but it is better regarded from the point of view explained in connection with third harmonics.

With a single triode the load-line is distorted unsymmetrically because of the lower bend in the anode characteristic. But with a pentode both ends of the load-line AOB (Fig. 2) may be cut short, one by the ordinary anode bend and the other

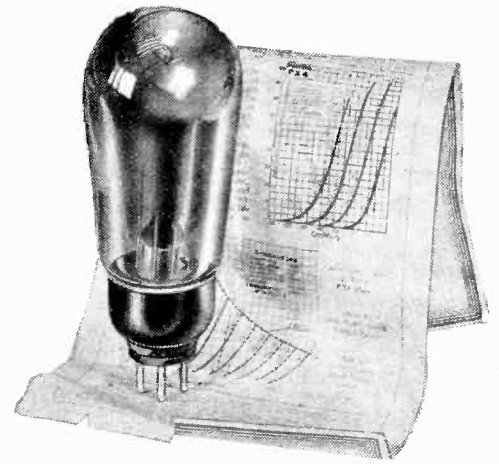

by the closing up of the curves at the region A.

### Pentodes

An examination of Fig. 3 shows that a third harmonic represents this effect of reducing both peaks symmetrically, since the harmonic is then always out of phase with the fundamental at the peaks. Hence the distortion produced by a pentode may be mainly third harmonic. Actually the pentode load-line is not exactly symmetrical, so that there may be a certain amount of second harmonic in addition. So far we have only considered the peaks of the wave-form, but it is obvious from the figures that the harmonics will represent changes in the other portions of the wave as well. Consequently, where a simple second or third harmonic represents too much distortion in some parts of the wave, other harmonics of higher order must be introduced to counteract the effect of the lowest harmonics where they are not required; but they will be largely even harmonics in the case of unsymmetrical distortion (triode) and odd harmonics with symmetrical characteristics (pentode, push-pull, etc.). It is usual to assume that in practical amplifiers these higher harmonics are of such small magnitude that they do not appreciably affect the amplitudes of the peaks of the wave-forms.

### “Class B” and Q.P.P.

With “Class B” there is some risk of distortion of the middle of the characteristic as well as the ends. For if the valves are under-biased they will both be in action at once for small voltages, and so will over-amplify the middle portion of the wave near the zero line. If, on the other hand, the valves are over-biased, they

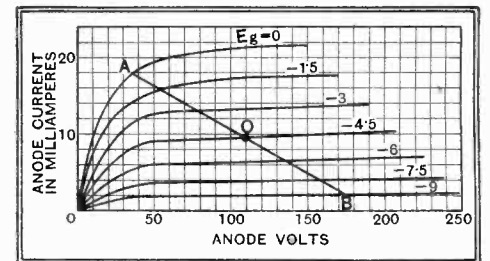

Fig. 2.—In a pentode overloading may occur at both ends of the load line, which restricts both peaks of the fundamental and gives rise to third harmonic distortion.



**Harmonic Distortion—**

will neither of them function properly on small inputs, and this portion of the wave will be insufficiently amplified. Now in Fig. 3 the third harmonic adds to the fundamental at points near the zero line, so that there is here an increase in the amplification of the part of the wave near the zero line. But we cannot reverse the phase of the third harmonic to represent

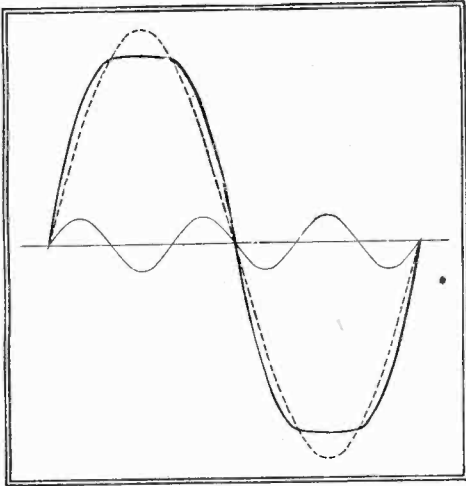

Fig. 3.—The presence of third harmonic reduces both peaks of the fundamental symmetrically. For the sake of clarity the amplitude of the harmonic in this figure and in Fig. 1 has been exaggerated.

a decreased amplification near the zero line, for this would also reverse the effect at the peaks; so, for this case, we must replace some of the third harmonic by fifth harmonic to produce the desired effect. It would be interesting to investigate whether there is any difference in the degree of distortion which will pass unnoticed in the two cases; probably fifth harmonic would be preferable, and in the interests of economy the valves are far more likely to be set for this condition.

With Q.P.P. there will normally be no grid current, so that only the centre of the characteristic, and not the ends, will be distorted. Accordingly we may adjust the phase of the third harmonic to suit the distortion of the middle of the wave, but we must always bring in appreciable amounts of higher harmonics to restore the peaks to their undistorted form. Inaccurate matching, however, will introduce second harmonic by destroying the symmetry.

Since power is proportional to voltage squared, the peak of the wave-form has a predominant effect on the power output, and an increase in amplitude at points near the zero line cannot balance an equal decrease at the peaks; consequently, a distortion of the wave-form means that for a given amplitude the power is not the same as it would be with a pure sine wave. With second harmonic we have already found that the output was decreased by the distortion, and with "Class B" it can be shown that 5 per cent. third harmonic caused by curtailing the ends of the load-line results in a power loss of 9.5 per cent. The calculations for Q.P.P. are more complicated, but since the peaks are unaffected by the distortion

we may expect the change in power to be small. It is clear from Fig. 3 that the third harmonic is zero whenever the fundamental is zero, so that we require no D.C. component when the distortion is symmetrical, and third harmonic is

accompanied by no change in mean current. Consequently, the anode current meter gives no indication of this distortion, and we must rely upon the ear or use an analyser which can measure the amplitudes of the separate A.C. components.

# THE B.B.C. OCTOPUS

## How the New Land Lines are Planned.

**L**AST week an important transfer of B.B.C. land lines took place, constituting Birmingham, instead of Leeds, as the main exchange between North and South. The accompanying map shows not only the disposition of lines as they are to-day, but includes Droitwich as well as the North Scottish and North Eastern, the two new high-power stations which are expected to be in operation by the summer of 1935.

To supply adequate links between all the B.B.C. transmitters, studios, and repeater points has involved a line mileage of nearly 4,500, practically one and a half times the distance between Liverpool and New York. It is worth noting, however,

that these lines are not all available at any given time for B.B.C. purposes.

The B.B.C. leases the lines from the General Post Office, which holds the monopoly of all communication in Great Britain. Certain of the lines are available for broadcasting only at stated times, and in some cases at least a week's notice must be given before the line can be guaranteed available for programme uses.

Between the main centres, however, the lines have been installed exclusively for broadcasting, and these are designed to give a level frequency response between 30 and 8,000 cycles. The average band of frequencies covered is between 30 and 6,500 cycles.

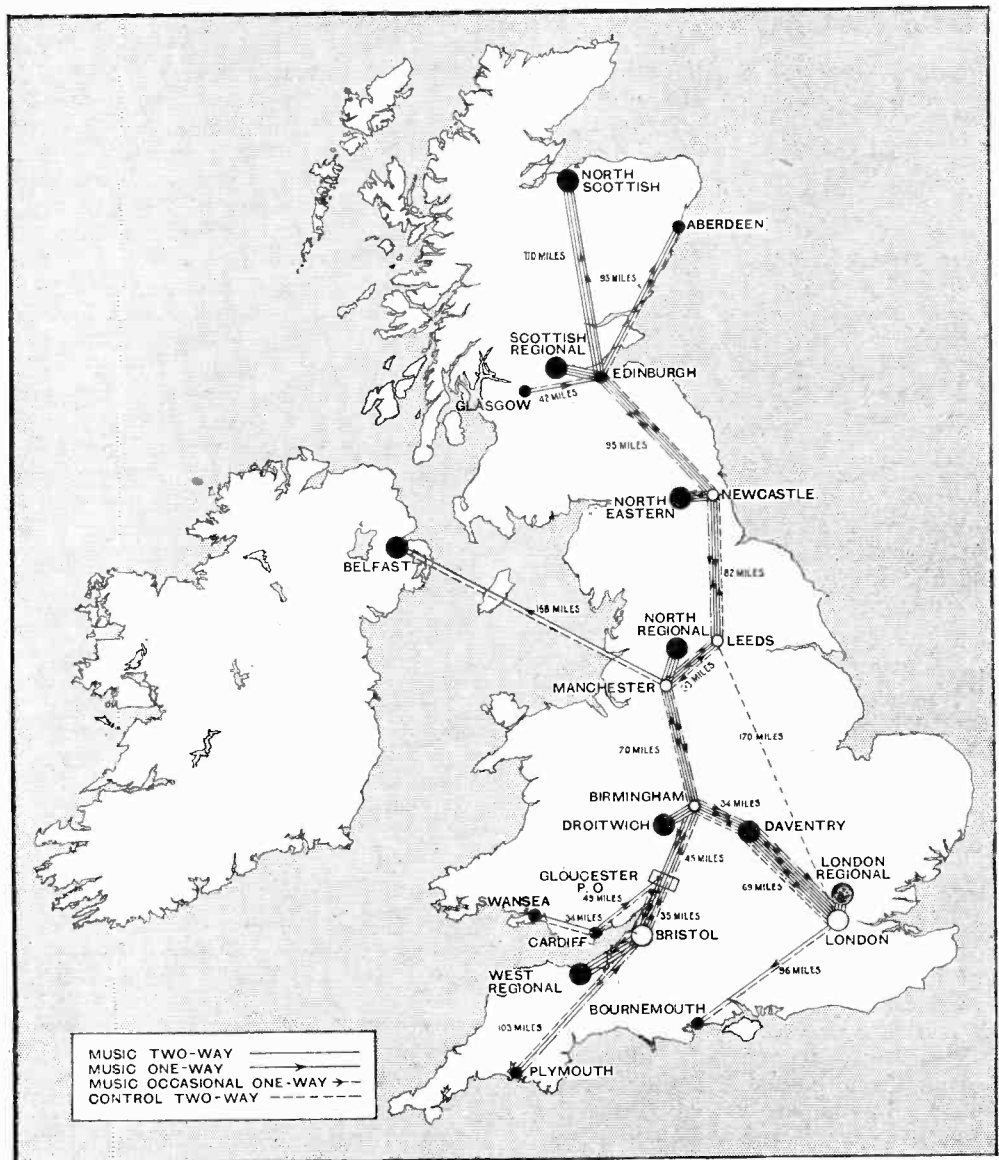

How far do your B.B.C. programmes travel by land line? A glance at the map will answer the question.

# Practical HINTS and TIPS

## AIDS TO BETTER RECEPTION

THERE can be no doubt that the operation of trimming the tuned circuits of a receiver by aural means is made more difficult by the inclusion of A.V.C. It therefore follows that the use of some simple indicating device, such as an anode

### Trimming A.V.C. Sets

current milliammeter, is particularly desirable when this form of control is fitted.

Failing a meter, it is generally worth while going to the trouble of making the necessary disconnections in the A.V.C. circuit, so that it may be temporarily out of action while the operation of trimming is being carried out.

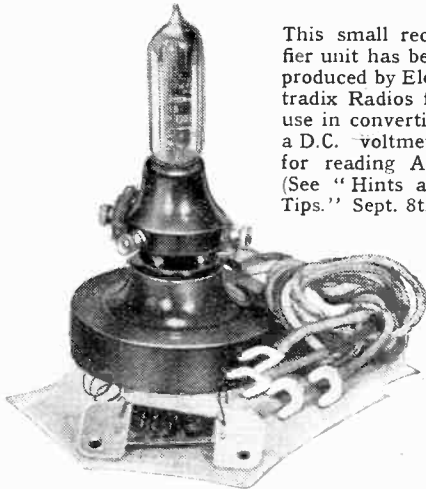

This small rectifier unit has been produced by Electradix Radios for use in converting a D.C. voltmeter for reading A.C. (See "Hints and Tips." Sept. 8th.)

WHEN the long days of summer give way to the long nights of winter almost every user of a broadcast set is apt to think that his apparatus is behaving abnormally. At this time of year receivers generally seem to have gained in sensitivity, although to offset this an apparent decline in selectivity is generally noticed.

### Seasonal Variations

For both these effects the influence of darkness on the propagation of wireless waves is entirely responsible. Not only do we receive more stations after dark, but, in spite of fading, the average strength of incoming signals from distant transmitters is increased. A foreign station which in daylight will cause no interference may, after dark, be sufficiently strong to spoil the reception of a comparatively near-by transmitter.

Even short-range quality sets are not immune from these effects. Although intelligible interference from distant stations may not be heard, it is quite possible that their carrier waves may be sufficiently strong after dark to cause an audible whistle due to heterodyning of the local station.

Of course, the reason why these effects are so much more noticeable in winter is that most of our listening during that season is done during the hours of darkness.

INSTABILITY in an amplifier of any kind is caused by the feed-back of energy from the output to the input end. The tendency towards instability increases with overall magnification; that is why, in a highly sensitive multi-stage set, meticulous care has to be taken to avoid interaction, both between one stage and another as well as between input and output of H.F. and L.F. amplifiers.

### Ganged Condensers

Here we are concerned solely with the H.F. amplifier. Experience shows that instability (or uncontrollable self-oscillation) in modern sets is very often due to the ganged tuning condenser. Although the actual way in which energy is transferred from circuit to circuit through the intermediary of this component is somewhat obscure, a glance at Fig. 1 will suggest that some care should be taken in making the connections to it. In considering this diagram, it is to be understood that the three variable capacities  $C_1$ ,  $C_2$  and  $C_3$  are actually single sections of a triple condenser, which will therefore be common to all three tuned circuits.

One set of plates (the rotor section) of each condenser is shown as being earthed, and the greatest care must be taken to see that this earthing is done thoroughly, in such a way that there is no resistance or impedance which will be common to two

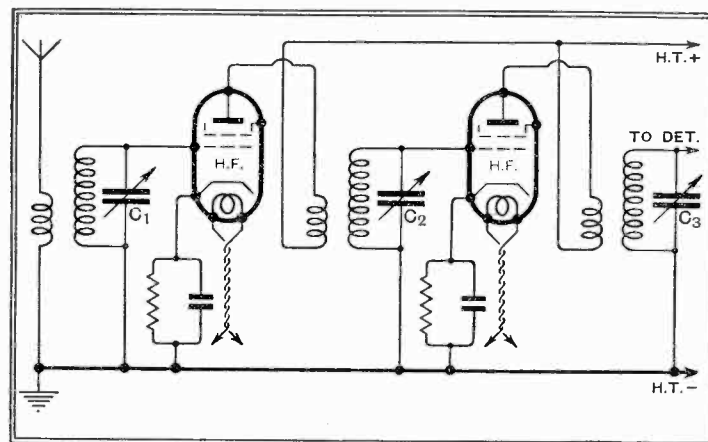
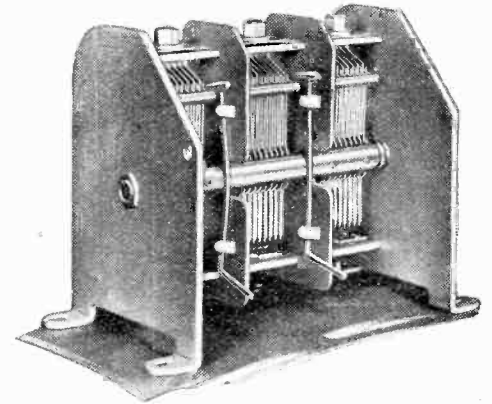

Fig. 1—A simple two-stage H.F. amplifier. The ganged condenser  $C_1$ ,  $C_2$ ,  $C_3$  is associated with all three circuits, and is a possible source of interaction unless each rotor section is perfectly earthed.

or more circuits. Most definitely, a single earth connection at one end of the condenser frame is not enough; wired in this way, some of the condenser sections will be bound to carry H.F. energy which

really belongs to another circuit. Nothing less perfect than two well-made earth connections, one at each end, should be tolerated in a high-gain amplifier.

Further, most modern condensers are fitted with inter-section contact springs bearing on the spindle. When instability is encountered, it will be worth while to remember that the soldering tags on the ends of these springs are for use, and not for ornament; they should be joined



How spindle contact springs are fitted in typical modern condensers.

directly to earth, preferably near to the cathode terminal of the valve with which the condenser section is associated.

IT has often been advised that the practice should be cultivated of keeping a record of the anode currents of the various valves in a receiver when new, and of checking the figures periodically. By doing this an early indication is obtained

### Ageing Valves

of any tendency towards failure of emission; in this matter the measuring instrument is a much more reliable guide than the human ear, for distortion and loss of sensitivity due to ageing of a valve sets in very slowly, and the resulting deterioration of performance is of a kind to which the ear becomes atrophied.

Failing emission manifests itself aurally in a number of ways, and, so far as L.F. amplifying valves are concerned, it generally becomes evident through an increased tendency towards early overloading. In certain types of amplifier, particularly those designed for high quality, the use of a valve with low emission may be responsible for severe amplitude distortion of a type which will make the reproduction appear high-pitched. As a general rule, indeed, it may be taken that an apparent over-emphasis of high notes in a receiver which was originally well-balanced is a sign of failing valves.



# The Climax Model S4

## A Selective Four-valve Superhet

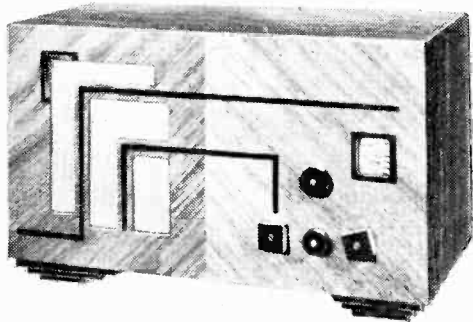

**T**HE four-valve superheterodyne class of receiver, to which this set belongs, is now rightly regarded as the best type for general-purpose reception of both local and foreign stations. It provides the necessary degree of selectivity required under modern conditions, and from the point of view of quality of reproduction is not inferior to the straight three-valve receiver which it is now rapidly replacing.

The cabinet is of very modern design and the rectangular motif is carried out even to some of the control knobs. This is an excellent arrangement as far as the wave-range switch is concerned, but the volume control which is also fitted with a square knob may require to be set in a position which does not altogether harmonise with the lines of the design. The cabinet is of the horizontal type in which the loud speaker is on the same level as the controls, and it may be supplied as a table model or complete with a separate pedestal for two guineas extra.

The tuning dial is viewed through a rectangular aperture and is engaged with bold wavelength graduations as well as the names of the principal stations. A novel effect is produced by illuminating the scale with a green-tinted pilot lamp.

### Accurate Calibration

On test we found the calibration of the scale to be far more accurate than is customary in sets of comparable price, and in no case did the setting of the stations vary by more than the depth of the lettering on the dial.

The set gave a very convincing performance on the score of selectivity and sensitivity, and, having regard to the fact that only four stages are employed, we can unhesitatingly award full marks in both these categories. In Central London adjacent channel separation can be relied upon on all stations with the exception of the two locals, but even here only one, or at the most two channels were lost on either side. On long

**FEATURES.** *Type*:—Table or pedestal model superheterodyne receiver for A.C. mains with moving-coil loud speaker and provision for gramophone pick-up. *Circuit*:—H.F. pentode det.-osc.—variable-mu I.F.—triode second detector—pentode output valve. Full-wave rectifier. *Controls*:—(1) Tuning, with illuminated and calibrated scale. (2) Wave-range and gramo. switch. (3) Volume control. (4) Tone control. *Price*:—(with pedestal) 14 guineas. *Makers*:—Climax Radio Electric Ltd., Haverstock Works, Parkhill Road, Hampstead, N.W.3.

waves Zeesen was received at unusually good strength and clear of Daventry and Radio-Paris. Over a few degrees at the lower end of the long-wave band, a certain amount of instability was noticed

which was not influenced by the volume control. There was a commendable absence of second channel interference, and the only point at which this occurred was in the vicinity of Milan and Poste Parisien on the medium waveband.

While there is not too much output in the bass, the quality in the middle and upper registers is clear-cut and suggests the good reproduction of transients. The cabinet walls are only 1/4 in. thick, but there is no evidence of any tendency towards box resonance.

The circuit is straightforward in design, and, while nothing has been omitted which has proved to be detrimental to the results, economy has been observed in the matter of decoupling and by-pass condensers across bias resistances. After all, the criterion of performance as regards decoupling is stability, and, if we except a small band of frequencies at the unimportant lower end of the long-wave range, the behaviour of the set on this score may be regarded as satis-

factory. As far as the bias arrangements are concerned the omission of the by-pass condenser does not affect quality, but only reduces volume for which compensation has been provided by the necessary extra amplification. The reduction in the number of resistances probably accounts for the fact that background hiss is below the average.

### Modern Valves

The first valve in the circuit is of the H.F. pentode type and performs the dual function of oscillator and first detector. It is preceded by a band-pass input filter, and is followed by an I.F. stage in which there are four tuned circuits. Volume is controlled by varying simultaneously the screen potential of both these stages, and the grid bias of the variable-mu I.F. valve. A section of the wave-range switch is used to

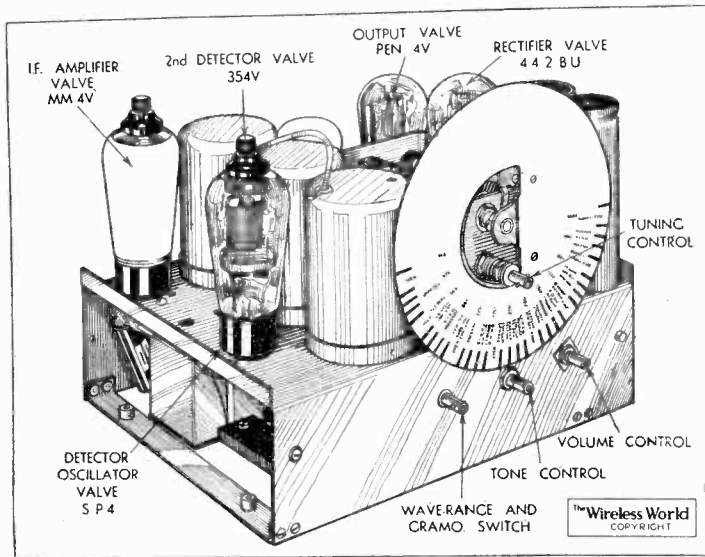

Chassis of the Climax S4 receiver viewed from the front.

interrupt the H.T. supply of the detector-oscillator when reproducing gramophone records. The second detector is a triode, and is coupled to the power pentode output valve through a miniature parallel-fed transformer of the high permeability type.

Tone control is effected by a variable condenser shunted across the whole of the transformer winding.

The power supply circuit is straightforward, and smoothing, which is carried out by including the loud speaker field in the H.T. lead in conjunction with two electrolytic condensers, reduces the hum to a negligible level.

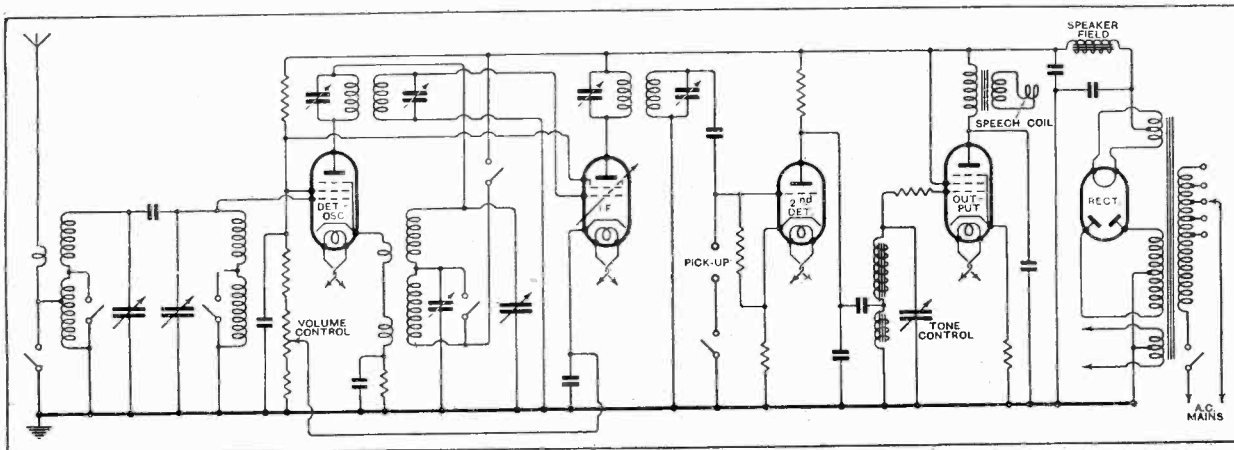

The circuit has been simplified by the omission of decoupling resistances and bias condensers.

Next Week's  
Set Review :  
**BUSH RADIO  
BUSHRANGER**

## Letters to the Editor:—

# Alternatives to the Disc Record

## Range of B.B.C. Stations : Electricity Charges

The Editor does not hold himself responsible for the opinions of his correspondents

I SHOULD like to endorse everything Mr. King said in his letter to you on the subject of alternatives to the disc record.

When is the gramophone to be brought up to date?

It is high time that gramophone companies really considered this matter, the thing can be done and it only wants a lead to be given. While we have a lot to thank the recording companies for, I don't think they are to be congratulated on missing (or shelving, perhaps) a device to give us uninterrupted entertainment.

The record changers on the market are, after all, simply a compromise.

Writtle, Essex. W. GEORGE.

I WROTE to one of the leading gramophone and record manufacturers about three years ago, suggesting that a gramophone on the sound-on-film principle would be a good scheme, asking if they were experimenting with anything of the kind, and how soon such a machine was likely to appear on the market.

After a very short correspondence, in which they neither denied nor admitted anything, I was more or less told to be quiet and mind my own business.

W. V. TUGWELL.

Wotton-under-Edge, Glos.

I HAVE thought of writing a letter similar to that of Flight-Lieut. Patrick King for many months past. I very heartily endorse all that he says. The reproduction of records—the best records on the best reproducers—leaves a lot to be desired from a musical point of view, owing to the cut-off of the higher frequencies. I have yet to hear a piano record which sounds like a piano. Broadcast piano music on a good set can be, and is, practically indistinguishable from the real thing, but every piano record I've heard yet sounds as though the piano used needed tuning and all the ornaments taken from off the top. My prejudice against gramophones and disc records grows daily by comparison with good broadcast reproduction, and I shall never trouble about them until we have such a type as Flight-Lieut. King suggests.

I don't wish it to be inferred that gramophones are a wash-out, but simply that, from a musical standpoint, they are not as good as they might be, owing to high-frequency cut-off. This point, I believe, has already been argued at length in your Correspondence columns. I trust the big gramophone companies will favour us with a reply.

INTERESTED.

Newcastle-upon-Tyne.

WE hope the following remarks concerning the photo-electric gramophone will be of interest to your correspondent, Flight-Lieut. Patrick King.

The reasons which have led this company not to market such a machine as he describes up to the present are:—

(1) Film is, we believe, the only satisfactory base for photographic recording.

The high cost of this material would mean that the public would have to pay at least twice the present cost of recording on discs for the privilege of having it on film.

(2) Apart from the cost of film records, which make them uncommercial, it is also extremely difficult to produce them. Shellac records can be stamped out in thousands without difficulty, but films can be produced by direct printing from the negative only.

(3) At the present stage of radio and gramophone progress a reproducer for film records, if they were marketed, would cost at least twenty-five guineas, whereas disc records may be reproduced on acoustic instruments which are bought for far less than this sum.

(4) If Flight-Lieut. King is unable to enjoy records when played on the automatic changer, due to the intervals of eight seconds whilst the discs are being changed, we suggest that he should have a two-turn-table unit made specially for him, when complete works recorded on more than one disc can be played through without a break.

(5) Even up till the present day "His Master's Voice," from the outset of their career, have recorded the masterpieces of classical music, several of which have shown nothing but a substantial loss, but it is part of the Company's policy to do all it can in furthering the cause of appreciation of good music. Your correspondent has only to examine the record catalogues of "His Master's Voice" from 1903 onwards to confirm these facts.

RICHARD ARBIB,

Manager, Press Department,  
The Gramophone Co., Ltd.

Hayes.

### Range of B.B.C. Stations

IN your editorial of October 13th you state that transmitters on exclusive wavelengths of the order of 261 metres have an "after-sunset range," which you "conservatively place at 200 miles."

My experience of the London National transmitter (which is eighty-five miles distant) before the West National transmitter was superimposed upon it, does not support your statement. At only rare intervals was good reception possible after sunset. On most occasions it was badly marred by the most terrific distortion.

North Regional (120 miles distant), though more reliable than many stations owing to its higher wave, suffers badly from this type of distortion, which makes the reproduction of the Hallé Orchestra vary in pitch from a team of piccolos to a consort of bass drums. The combination of London National and West National is—outside its small local areas—useless owing to the rapid rhythmic beat interference, which results

Correspondence, which should be as brief as possible, should be addressed to the Editor, "The Wireless World," Dorset House, Stamford Street, S.E.1, and must be accompanied by the writer's name and address

in this wave channel being a mere noise over two-thirds of the South of England.

The policy of the B.B.C. in radiating its expensive Dance Orchestra from these stations, while the Midland Regional enjoys two separate "Children's Hours," is somewhat mystifying.

H. H.

North Gloucestershire.

### Electricity Charges

THE complicated tariff of charges given in "Colonel's" letter in your issue of October 13th calls for comment.

One would need an extra room to accommodate the meters which he imagines to be necessary!

I am being served by a two-part tariff: A fixed charge of 12s. per quarter and  $\frac{1}{4}$ d. per unit for all energy consumed, the rent of the single meter being 1s. per quarter. This means electricity being really cheap and usable. Consumers are able to "blossom out" with fancy lighting effects, electric soldering-irons, lawn-mowers, and other devices without worry. Why are not such tariffs more general? A really cheap supply everywhere—though it may be costly to the suppliers at first—would soon stimulate consumption, and would also benefit the manufacturers and retailers of electrical appliances.

H. H.

North Gloucestershire.

## THE RADIO INDUSTRY

AT the recent International Exhibition of Inventions, Voigt Patents, Ltd., were awarded a gold medal certificate for a loud speaker fitted with their new type of diaphragm, which covers an exceptionally wide range of audio-frequencies.

Sinclair Speakers, of 49-50, Twyford Street, London, N.1, tell us that their telephone number is now *Terminus* 4355-4356, and that they are opening a Scottish branch at Baltic Chambers, Waterloo Street, Glasgow.

A large Tannoy radio-gramophone, with a number of extension loud speakers, has recently been installed on board H.M.S. Leander.

At last those who take an intelligent interest in their receivers are realising that a measuring instrument is an almost indispensable adjunct. In support of this opinion the makers of the Pifco Rotameter, an eight-range measuring instrument, inform us that the public demand has greatly exceeded their most sanguine expectations.

The Ever Ready Company has just opened its eighth dry-battery factory in the London area. The new establishment at Walthamstow is primarily intended for the manufacture and assembly of comparatively small cells, as used in radio batteries and electric torches, and is equipped with the most modern machinery for dealing with each stage of production, from the raw material to the finished article.

### Change of Address

C. Webb, Ltd., special London agents for Eddystone short wave products, from 146, Charing Cross Road, to 14, Soho Street, London, W.1. Tel.: *Gerrard* 2089.



# New Apparatus Reviewed

## Latest Products of the Manufacturers

### MAZDA AC/S<sub>2</sub>/PEN VALVE

THE Mazda AC/S<sub>2</sub>/Pen is a steep slope H.F. pentode-type valve for A.C. mains operation and has been designed primarily for use as the frequency changer in super-heterodyne receivers. It is fitted with a seven-pin base with the connections arranged as now standardised for indirectly heated H.F. pentodes of this type.

The valve may be used either as a combined oscillator detector or in conjunction with a separate oscillator, but, whichever arrangement is adopted, cathode injection is advised since re-radiation will then be appreciably less than with injection into either of the outer grids. Self-oscillating frequency changers of the high-gain variety are very prone to "squegger," but this can be avoided by keeping the time constant of the bias resistance and its condenser small; suitable values for the AC/S<sub>2</sub>/Pen would be 1,000 ohms and 0.1 mfd. respectively. Used in this manner an anode potential of between 200 and 250 volts is desirable, the screen grid may be given 100 volts and a negative bias of two volts applied to the control grid. The suppressor grid should be joined to the cathode and the metallising to the earth line.

Measurements made with a specimen valve using 250 volts on the anode, a screen potential of 100 and -2 volts grid bias, gave the mutual conductance as 4.05 mA/volt, the A.C. resistance for this set of conditions being 1.14 megohms. The anode current was 6.6 mA, and the screen current 2.1 mA. These results are substantially in agreement with the maker's rating, for the mutual conductance is given as 4 mA/volt under working conditions. With 4 volts A.C. the heater current is 0.97 amp.

The AC/S<sub>2</sub>/Pen costs 17s. 6d., and it is obtainable from the Edison Swan Electric Co., Ltd., 155, Charing Cross Road, London, W.C. 2.

### NEW AMPLION H.F. CHOKE

THE latest addition to the Amplion range of components is a screened H.F. choke of high inductance which is suitable for general purpose use. It is wound on an ebonite former and sectionalised to ensure a low self-capacity, the maker's value being 4.5 m-mfds. On test the choke was found to be entirely satisfactory, the only resonance of any consequence falling at the very top of the medium waveband.

Its D.C. resistance is 650 ohms, and the inductance, measured at 1,000 cycles, 0.175 henry. The last-mentioned quantity will

only be of interest if the choke is employed in a tone-corrected circuit where a knowledge of its low-frequency inductance would be necessary.

It is mounted on a moulded bakelite base, and an earthing point is provided.

Amplion screened H.F. choke.



The makers are Amplion (1932), Ltd., 82-84, Rosoman Street, Rosebery Avenue, London, E.C.1, and the price is 3s. 6d.

### EPOCH A2½ LOUD SPEAKER

FROM the external appearance it is evident that this unit is something a little out of the ordinary, and a closer inspection reveals many points which will commend it to the discriminating buyer. The diaphragm, for instance, is very freely suspended, and a soft leather surround takes the place of the usual moulded corrugations in the cone. The centring spider is also more flexible than usual, and, as might be expected, the bass response is excellent and is maintained fairly uniformly over a band from 65 to 95 cycles. There is a slight depression in the region of 200-300 cycles, but between 300 and 2,500 the output is aurally uniform. At the latter frequency there is a rise of about 6 db., which is maintained to 8,500 cycles, after which the response falls rapidly. There is no definite high-note resonance, and the performance at this end of the scale could hardly be bettered.

The efficiency is good and was equal to our energised standard loud speaker in the bass and above 2,500 cycles; but for the dip in the lower middle register the general level of efficiency would have been the same.

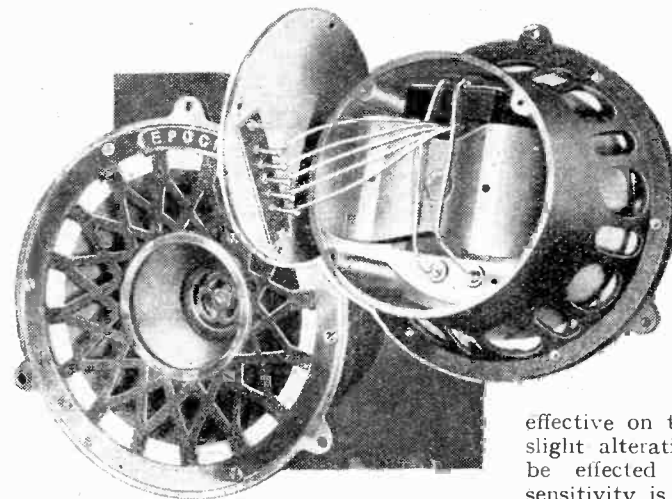

The Epoch A2½ permanent magnet loud speaker unit is effectively protected by a cast aluminium housing and diaphragm grille.

Mechanically the A2½ is exceptionally strong, and a high degree of reliability is to be expected. The price is 3 guineas, and a ten-ratio output transformer is included. A Class "B" transformer may be fitted if required. The makers are Epoch Radio Manufacturing Co., Ltd., Exmouth House, Exmouth Street, London, E.C.1.

### BRYCE-LYNCH AERIAL SYSTEM

THE Bryce-Lynch Broadcast Aerial System has been introduced by W. Andrew Bryce and Co., Woodfield Works, Tile Street, Bury, Lancs, for combating interference generated by electric motors or domestic appliances and which render distant reception, and often that of the local station, impossible without a troublesome background of crackles and other objectionable noises.

It consists of a screened down-lead of comparatively small diameter with impedance matching transformers at each end. Its installation is simple and straightforward and entails very little alteration to the

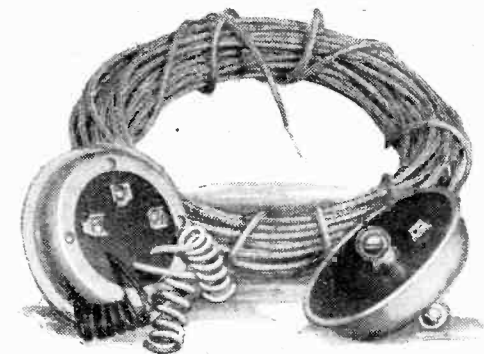

Bryce-Lynch screened aerial system comprising shielded cable and impedance-matching transformers.

existing aerial. The downlead is detached and one transformer is fixed to the remaining horizontal portion. The screened cable is then connected between this transformer and another which is mounted adjacent to the receiver.

Our tests show that the losses arising from its use on the medium waveband are very small indeed and will generally be taken care of by the reserve of sensitivity in the set. As with all screened down-lead systems interference is reduced in far greater proportion to the received signals, so that the full sensitivity of the receiver can be utilised where otherwise this would not be possible.

As the transformers are designed for the medium waves they are not quite so effective on the long waveband, but by a slight alteration in the wiring, which can be effected by an on-off switch, full sensitivity is regained, but with somewhat more background.

The price of the complete kit, including 50 feet of screened cable, is £2 5s.



# READERS' PROBLEMS

## Comparing Coils

TO settle an argument we are asked to describe a simple method of comparing the relative goodness of two different types of tuning coil. The querist who asks our help in this matter states that he possesses no laboratory apparatus, but is fairly well provided with voltmeters, milliammeters, and the usual collection of "bits and pieces" that every amateur accumulates.

On the assumption that the coils to be compared are of roughly the same inductance value, it is quite easy to test their relative efficiencies, but, of course, quantitative measurements of H.F. resistance or dynamic resistance are more difficult. Fortunately, they are unnecessary in this case.

For a quick and easy comparative test, the absorption method of testing cannot be beaten. The underlying principle is that a tuned circuit will abstract energy from another tuned circuit in which oscillatory currents are flowing when the two are coupled together. All other things being equal, the absorbing circuit with the most efficient coil will abstract the greatest amount of energy.

This principle is put into practice by setting up the circuit shown diagrammatically in Fig. 1. The test oscillator may consist of the plate and grid circuits of an ordinary reacting detector valve with a milliammeter in the anode circuit as an indicator. A

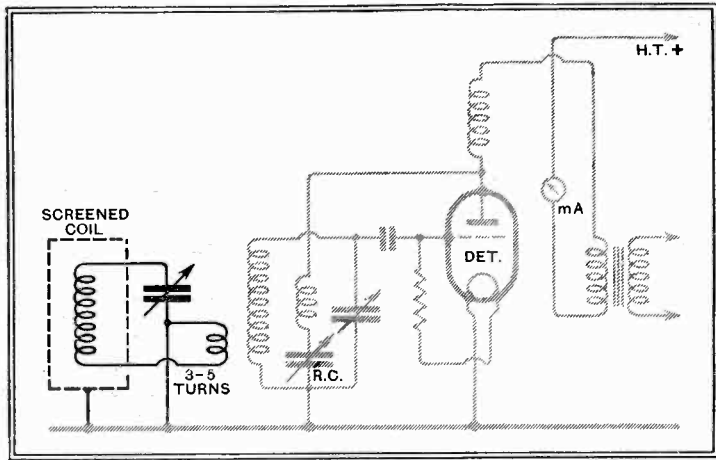

Fig. 1.—An improvised test for ascertaining the relative "goodness" of tuning coils at various wavelengths. The circuits of almost any regenerative receiver may be used.

coupling coil of a few turns is placed in inductive relationship with the oscillator coil, and is connected in series with the absorbing circuit of which the coil under test forms a part. For accurate comparisons it is essential that all coupling should take place through this coil, and that its position when once fixed should remain unchanged during the test. The best setting for a clear deflection is easily found after making a few trials.

Having set the detector valve into a state of self-oscillation by increasing reaction coupling, the condenser of the absorbing circuit is adjusted until the milliammeter indicates resonance by a sudden deflection. The extent of this deflection should be carefully noted; it will be a measure of the efficiency of the coil. Maximum deflection indicates maximum efficiency.

THESE columns are reserved for the publication of matter of general interest arising out of problems submitted by our readers. Readers requiring an individual reply to their technical questions by post are referred to "The Wireless World" Information Bureau, of which brief particulars, with the fee charged, are to be found at the foot of this page.

## Ideal Down-lead Screen!

A CORRESPONDENT has discovered what would appear to be almost a perfect screen for his aerial down-lead. He proposes to pass it through a sheet-metal ventilation shaft which happens to run from the roof to a position in close proximity to the receiver.

We imagine that a few practical difficulties are in the way of putting his plan into operation; for instance, it would be highly desirable that the aerial down-lead should be centred in the shaft in order that its capacity to the metal should be as low as possible. If there are bends, it would appear none too easy to satisfy this requirement. But we think that the plan might be given a trial.

## Testing I.F. Windings

ALTHOUGH I.F. transformers do not often give trouble, it is as well to make a practice of testing them when the performance of a receiver is below par. For

example, a correspondent whose superheterodyne has lately shown a marked falling off in sensitivity, tells us that the secondary winding of his second I.F. transformer "seems to be completely disconnected internally." As signals—of a sort—are still receivable, he is inclined to think that his method of testing is at fault.

In all probability the winding has actually failed. It is by no means uncommon to find that there is sufficient stray coupling between the circuits to allow the set to go

## The Wireless World INFORMATION BUREAU

THE service is intended primarily for readers meeting with difficulties in the construction, adjustment, operation, or maintenance of wireless receivers described in *The Wireless World*, or those of commercial design which from time to time are reviewed in the pages of *The Wireless World*. Every endeavour will be made to deal with queries on all wireless matters, provided that they are of such a nature that they can be dealt with satisfactorily in a letter.

Communications should be addressed to *The Wireless World* Information Bureau, Dorset House, Stamford Street, London, S.E.1, and must be accompanied by a remittance of 5s. to cover the cost of the service. The enquirer's name and address should be written in block letters at the top of all communications.

on working even when the secondary is completely disconnected. A break in the primary winding, however, will usually render the set dumb.

When testing the windings for continuity, it is also as well to make a rough test of ohmic resistance, if apparatus for doing so be available. Usually the resistance of typical I.F. couplings amounts to 50 ohms or more, and so a comparative test can be made without sensitive instruments. In most modern transformers, primaries and secondaries have the same resistance.

## A.V.C. and Detuning

A READER is somewhat perturbed to find that the signal strength obtainable from his receiver (fitted with A.V.C.) is increased slightly but definitely by very slight detuning. In other words, maximum loudness of signals is obtained by rotating the tuning condenser a small part of a degree on either side of the position corresponding to true resonance (as shown by the tuning indicator).

This effect is by no means unusual. The effect of slight detuning is to decrease the H.F. voltage due to the carrier wave that is applied to the detector grid; due to the action of A.V.C., this will increase the overall sensitivity of the set, and so greater volume may be obtained while the circuits are tuned to the side-bands rather than to the carrier wave. But this increase of volume is only obtained at the expense of quality.

# CLUB NEWS

## Welcome to the New Premises

All radio enthusiasts in the neighbourhood are invited to the meetings of the Catford Radio and Television Society in their newly acquired premises at 257, Bromley Road, S.E.6. The greater part of the Society's time this session is being devoted to practical work. The Prince de Mahé has been elected President.

Hon. Secretary: Mr. H. Floyd, 38, Como Road, Forest Hill, S.E.23.

## Measuring Light

"The Spectrum of Radiant Energy" and "The Measurement of Light" are among the subjects of interesting lectures and demonstrations to be given before the Radio, Physical and Television Society. New members are cordially welcomed and enquiries should be addressed to the Secretary, Mr. F. J. Bubear, 67, Nassau Road, Barnes, London, S.W.13.

## For South London Transmitters

New members will be welcomed by the South London and District Radio Transmitters' Society, formed in March, 1931, and now ensconced in comfortable quarters at the Brotherhood Hall, Knights Hill, West Norwood. Meetings: First Thursday of each month at 8 p.m.

Hon. Secretary: Mr. E. C. Taylor (2AUQ), 29, Sundridge Road, Addiscombe, Croydon.

## Welcoming the Beginner

A special elementary class in "Wireless Theory and Practice" has been inaugurated for the benefit of new members of the Smethwick Wireless Society, which has arranged an attractive programme for the winter session.

Hon. Secretary: Mr. E. Fisher, M.A., 33, Freeth Street, Oldbury, Nr. Birmingham.

## Short Waves and Television

All short wave enthusiasts and television amateurs are cordially invited to the meetings of the Thames Valley Amateur Short Wave Radio and Television Society, which is now organising transmitting and receiving tests as well as morse practice for beginners.

Hon. Secretary: Mr. Richard K. Shingold, Glenmore, Manygate Lane, Shepperton, Mddx.



# The Wireless World

THE PRACTICAL RADIO JOURNAL  
23<sup>rd</sup> Year of Publication

No. 742.

FRIDAY, NOVEMBER 17TH, 1933.

VOL. XXXIII. No. 20.

Proprietors: ILIFFE & SONS LTD.

Editor:  
HUGH S. POCOCK.

Editorial,  
Advertising and Publishing Offices:  
DORSET HOUSE, STAMFORD STREET,  
LONDON, S.E.1.

Telephone: Hop 3333 (50 lines).  
Telegrams: "Ethaworld, Watloo, London."

COVENTRY: Hertford Street.  
Telegrams: "Cyclist, Coventry." Telephone: 5210 Coventry.

BIRMINGHAM:  
Guildhall Buildings, Navigation Street, 2.  
Telegrams: "Autopress, Birmingham." Telephone: 2970 Midland (3 lines).

MANCHESTER: 260, Deansgate, 3.  
Telegrams: "Iliffe, Manchester." Telephone: Blackfriars 4412 (4 lines).

GLASGOW: 26B, Renfield Street, C.2.  
Telegrams: "Iliffe, Glasgow." Telephone: Central 4857.

PUBLISHED WEEKLY. ENTERED AS SECOND CLASS MATTER AT NEW YORK, N.Y.

Subscription Rates:  
Home, £1 1s. 8d.; Canada, £1 1s. 8d.; other countries abroad, £1 3s. 10d. per annum.

As many of the circuits and apparatus described in these pages are covered by patents, readers are advised, before making use of them, to satisfy themselves that they would not be infringing patents.

## CONTENTS

	Page
Editorial Comment .. ..	385
Fitting a Pick-up .. ..	386
Practical Hints and Tips .. ..	388
How Europe will Re-tune .. ..	389
Radio Gramophone Conversions ..	390
News of the Week .. ..	392
PROGRAMMES FROM ABROAD, pp. I—XXIV	
Broadcast Brevities .. ..	393
Unbiased .. ..	394
Television Explained .. ..	395
Tone Compensating Devices .. ..	397
Detector Interaction .. ..	398
Bush Radio "Bushranger" .. ..	399
Letters to the Editor .. ..	400

## EDITORIAL COMMENT

### Broadcasting and the Record

#### A Defence of B.B.C. Policy

**T**HERE has been some criticism of the B.B.C. recently for the extended use of recordings for broadcasting. There has it seems been one instance (probably many more) where the B.B.C. has mixed in recorded items with direct broadcasting before the microphone. There does not seem to be any particular objection raised by the critics to broadcasting gramophone records where the listener is told that what he is listening to is, in fact, a record. The critics are, it would seem, questioning the desirability of putting over a recorded item without disclosing the fact to the public.

There are, of course, quite strong arguments which can be put forward on both sides, but we are inclined to think that the B.B.C. can very largely justify its policy, provided that in every instance there is a reason for substituting the record for the direct broadcast.

#### The Case of Plays

A former Director of Broadcasting in Berlin held strong views on this subject; he believed that musical works should, generally speaking, not be broadcast through the medium of a record except where questions of programme costs made it difficult to give a direct rendering. He inclined very strongly to the view that, for many broadcast items, and particularly for plays, the transmission from a studio recording was to be preferred to a direct performance. He gave as his reasons that many rehearsals might be carried out before a really satisfying

performance was given, where no hitch of any kind occurred and where all the performers were at their best. This, he considered, was the moment to seize and to record because very likely a direct performance would suffer from defects at the particular time that it was given. Actors might be indisposed and their voices suffer in consequence, or hitches might occur in the stage production itself.

#### Records a Valuable Asset

When the B.B.C. has made use of recording, we think it probable that this has only been done where the performers or speakers could not have been present in person at the time the broadcast was made. The risk which must be guarded against is the possibility that recording might come to be regarded as a ready substitute for the real thing, and here, particularly in the case of musical performances, quality would undoubtedly suffer. It would be disastrous for the B.B.C. thus to lower the standard of transmission quality, even though it must be admitted there are still comparatively few sets in the hands of listeners which are capable of doing full justice to the best quality which the B.B.C. puts out.

Any critic who argues that the B.B.C. should discontinue the use of recording as an adjunct to broadcasting is, in our opinion, proposing to deprive broadcasting of one of its most important assets. The record and other artificial devices are used extensively for the production of outside noises and effects, many of which it is difficult, if not impossible, to reproduce on the stage. Broadcasting should make every legitimate use possible of this aid, and it must be left to the good sense of programme producers to see that it is not abused.

# Fitting a Pick-up

## How to Adapt Existing Sets for Gramophone Reproduction

*THIS article, written for the wireless user who has not previously attempted to reproduce gramophone records through his set, shows that the necessary alterations are of the simplest nature. Both permanent and temporary conversions are discussed.*

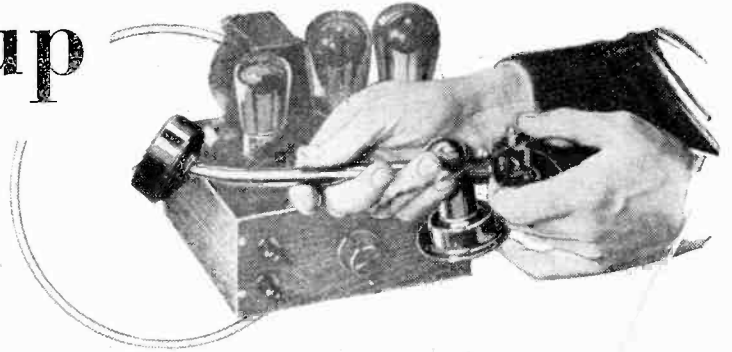

IT is strange that the average owner of a receiver, when considering the question of modifying it for gramophone reproduction, seems to suffer from what is nowadays called an inferiority complex. Actually, there is

minor circuit alterations necessary may be effected.

Basically, all we have to do is to make arrangements to join the pick-up, in series with a source of grid bias, between grid and filament of the first L.F. amplifier

the grid condenser are effectively in parallel with the pick-up seldom has any prejudicial effect on performance. A switch is fitted for convenience, in order that the pick-up circuit may be connected to, or isolated from, the valve grid at will.

This, in the simplest terms, represents the normal way of connecting a pick-up, and is applicable either to battery or mains sets. In the mains set, however, it will almost always be desired to replace battery bias by automatic bias; this can be done by adopting the circuit arrangement of Fig. 1 (b). Here we have a beautifully simple and entirely automatic arrangement, whereby the operating conditions of the detector grid are varied to suit the particular function which that valve has to perform.

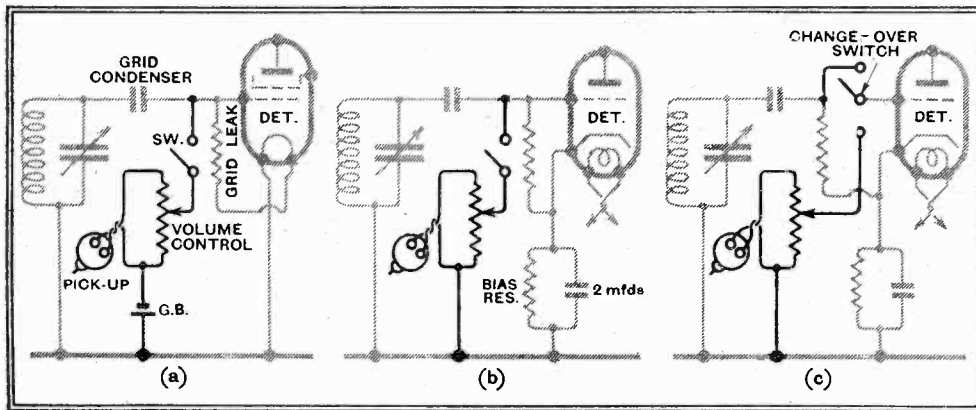

Fig. 1.—Methods of fitting a pick-up to both battery and mains receivers.

seldom any reason why the low-frequency portion of a good receiver should not also be a good amplifier for the purpose of reproducing records; from the point of view of convenience, the modified set can be made, by the exercise of ingenuity, at least as good as the conventional self-contained radio-gramophone. If, on the other hand, nothing more than occasional reproduction of gramophone records is required, a temporary "hook-up" may be improvised with small trouble and expense.

Almost every type of receiver is easily convertible, except, perhaps, those few sets of ultra-modern design in which a diode detector (or an H.F. metal rectifier) feeds directly into the output stage; with these sets considerable modification may be necessary, as it is generally essential that one of the earlier valves should be converted from its original purpose (probably that of I.F. amplifier) into an L.F. amplifier.

Nowadays, it is not far short of the mark to say that ninety-nine per cent. of sets include grid detection. All of these can be fitted with a gramophone pick-up with the greatest of ease, and with the virtual certainty that gramophone records will be reproduced just about as well as radio signals. Before discussing the pick-up and various other accessories that will be required it would be as well to put on record the various ways in which the

of the receiver. At the same time, provision must be made for clearing away any existing apparatus already connected to this circuit which might prejudice the operation of the pick-up. In practice, we will also need a volume-control device of some sort, as modern sets seldom include provision for regulating L.F. amplification. Neither does the modern set in-

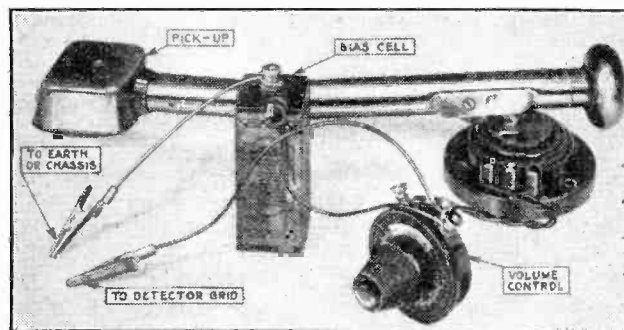

Fig. 2.—A simple way of adding a pick-up for temporary use.

clude an intermediate L.F. stage; therefore, the detector valve (which nearly always performs the function of amplifier as well) must be pressed into service as a gramophone amplifier, and the pick-up will be connected to it in the manner indicated in Fig. 1 (a). This represents almost the standard arrangement for battery sets; the fact that the grid leak and

### Battery or Automatic Bias

With regard to the actual value of grid bias voltage, it will almost always be correct to use a pressure of 1½ volts with battery sets. Indirectly heated mains valves require more bias, and as a rule three volts will be enough; when automatic bias is to be employed, a resistor of about 1,000 ohms connected in the cathode lead, as shown, will almost invariably be right.

Another method of fitting a pick-up is shown in Fig. 1 (c). This differs only from those already discussed, in that a change-over switch is used, by means of which the "radio" components in the grid circuit are completely disconnected for gramophone reproduction. In special circumstances this plan has its advantages, but it is perhaps not so gener-

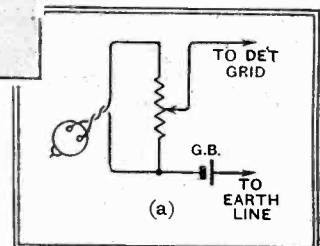

ally suitable for indiscriminate use as the simpler arrangement, and involves more disturbance of existing wiring.

Any set not more than two or three years old may with the greatest of con-



**Fitting a Pick-up—**

tidence be modified on one or other of these plans, even if one has no precise information as to the circuit arrangement employed. Anode-bend detection need hardly be considered nowadays, although the arrangement of Fig. 1 (c) is basically applicable either to battery or mains sets.

Another type of receiver requiring special treatment is that with diode detection, but fortunately there is no great difficulty here. All diode sets, except those of the very latest type mentioned in the first paragraph, have an intermediate L.F. stage, and all one has to do is to connect pick-up and volume control across the grid circuit of the L.F. amplifier which immediately succeeds the diode. At the same time, arrangements must be made to isolate the diode from the pick-up. More often than not this is most conveniently done by interrupting the filament circuit; the valve when cold will exercise no harmful effect on the pick-up characteristics.

Whatever method of fitting a pick-up is employed, it is always wise to try to mount the radio-gramophone change-over switch as close as possible to the valve with which it is associated. Long, straggling leads are likely to introduce instability, and are certain to add to the stray capacity existing across the detector grid circuit. Occasionally it will be impossible to put the former precept into practice, and to prevent uncontrollable self-oscillation it may be necessary to screen the lead which runs from the detector grid to the switch; this screening, if necessary, should be done with comparatively thin wire in wide-bore sleeving covered with metallic braiding. In any case, the addition of a pick-up will almost

from the internal wiring, and so may be joined to any pick-up circuit. There is no harm in leaving the adaptor always in position; to revert to radio-reception, the pick-up lead is removed from the upper terminal and the two adaptor terminals are then bridged by a link.

It is a matter of some importance that

on A.C. if a change-over should be made in the future. Motors intended for A.C. only may be either of the synchronous type, of which the speed depends on the mains frequency, or of the induction type, which allows a certain variation of speed. These two principles are combined in the B.T.H. "Truspeed" motor. Other well-known makes are Collaro, Garrard, and Simpson's Electricals.

For intermittent use, the turntable of an old acoustic gramophone will prove satisfactory; with a pick-up like the Harlie, which is designed to fit into the tone-arm in place of the usual sound-box, records may be reproduced electrically without any trouble. For portable gramophones, a very convenient attachment device, with volume control,

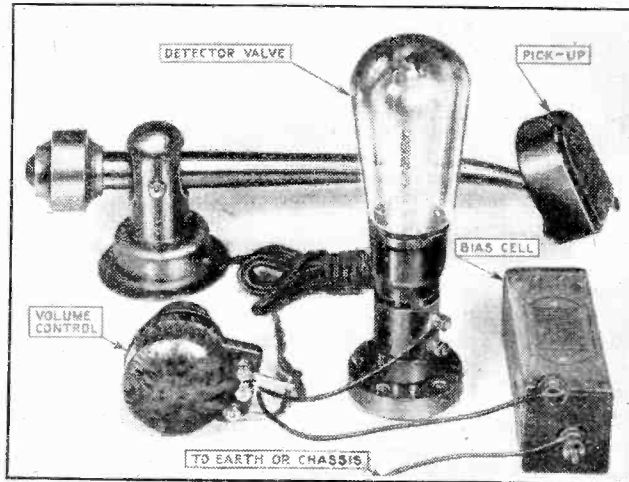
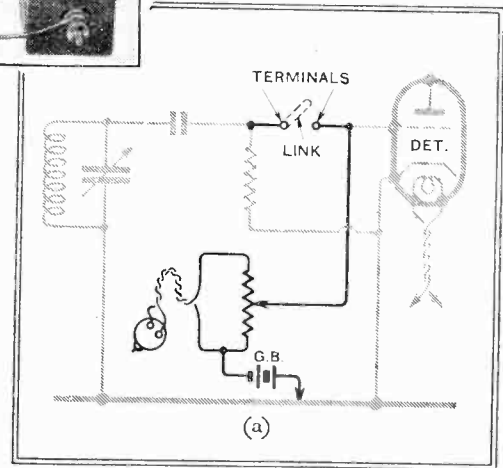

Fig. 3.—Another method, of almost universal application; connection with the valve grid is picked up through an adaptor (Bulgin).

the correct value of volume control potentiometer be employed. Many pick-ups, as, for example, the Blue Spot, Celestion and Cosmochord, are always sold with a built-in potentiometer, and so the question of choosing the right value does not arise. With others the makers' recommendation should be followed; failing information on this subject, the rule is that the higher the impedance of the pick-up, the higher should be the value of the shunt resistance. Too low a value will introduce attenuation of high notes, but this effect may sometimes be turned to good account; when high notes are over-emphasised a measure of tone correction may be introduced by using an abnormally low value of potentiometer. As a guide to the values in customary use for well-known pick-ups, the following list is given: Marconiphone (latest model), 50,000 ohms; B.T.H. Senior, 20,000 ohms; B.T.H. Minor, 10,000 ohms; Bowyer-Lowe, 50,000 ohms; Limit and Limit Reliance, 250,000 ohms.

**Rotating the Record**

So much for the electrical aspects of adding a pick-up. The mechanical side is fairly simple; we need a turntable for the record, and also a motor to rotate it at a steady speed (usually 78 r.p.m.). Where no mains are available clockwork motors must be employed; these are now extremely satisfactory, but, for obvious reasons, an electric motor is preferable. With D.C. supplies there is no alternative to the commutator motor, which is usually of the universal type, and so may be used



is supplied with the Belling-Lee pick-up.

All motors are supplied with the necessary fittings, and so installation is an extremely simple matter, as there is nothing to do but to mount the turntable above, and the driving motor below, a horizontal board, and then to fix the pick-up in the correct position with respect to the turntable spindle. In order to obtain correct tracking, the pick-up maker's advice should be followed implicitly; usually a template is supplied, and so there is no risk of error.

There is scope for ingenuity in the arrangement of the gramophone reproducing apparatus, and many users will prefer to mount these accessories in some form of "playing desk" like the devices described elsewhere in this issue. All sorts of refinements are, of course, possible; for instance, those who develop a keen appreciation of gramophone music will probably not rest content until they have installed an automatic record changer. These ingenious devices, of which a good example is made by Garrard, have now reached a high state of perfection.

In addition, the fitting of a number of small "gadgets," such as needle cups, indicating lamps, etc., which add to the convenience of record reproduction, may be considered; devices of this sort are made by Regent Fittings and Bulgin.

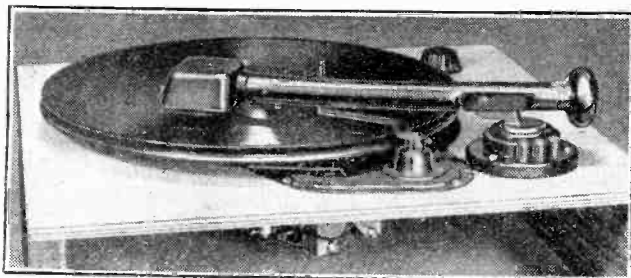

A "record playing desk" in its simplest form. The essential accessories are, pick-up, motor, turntable, and volume control.

invariably call for a slight readjustment of the detector grid circuit trimmer in ganged sets; in superheterodynes a corresponding adjustment of the condenser which tunes the last I.F. transformer secondary will be needed.

For a temporary conversion, the method of fitting a pick-up shown in practical form in Fig. 2, and theoretically in the inset diagram (a), is generally convenient. A connection to the earth line (H.T. negative) is always accessible, and similarly it will generally be easy to make a connection to the detector grid by means, say, of a spring clip, as shown. If, however, the wiring of the set is inaccessible, it will be convenient to use a "split grid adaptor" as in Fig. 3. This is a truly universal arrangement, as by the interposition of the adaptor the valve grid is entirely isolated



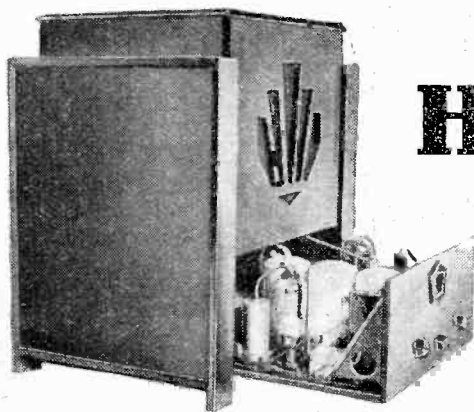

A cabinet, built by a reader, which combines easy accessibility for experimental purposes with the usual features of the modern domestic set.

# Practical HINTS and TIPS

## AIDS TO BETTER RECEPTION

These are connected in series across the condenser under suspicion, and, if everything is well, a click, due to the flow of charging current, should be heard on completing the circuit. Any click heard at the moment of interrupting the testing circuit is an indication of serious leakage, or of a complete short-circuit, while the absence of a click at "make" shows an internal disconnection. The smaller the condenser, the more difficult it is to make this test, and now that headphones have gone out of general use, it is perhaps not an entirely practicable one to suggest. A sensitive loud speaker may, however, replace the phones with fairly satisfactory results.

Another test is made by joining a sensitive measuring instrument—preferably a voltmeter—in series with an H.T. battery and the condenser. If everything is in order there will be a momentary deflection of the meter needle as the charging current flows into the condenser. A continuous deflection is indicative of leakage, while no deflection shows an internal disconnection. The weak point about this test is that it is only applicable to condensers of fairly high capacity—say not much smaller than 0.1 mfd.

WHEN automatic bias first came into use it was customary to obtain the necessary negative voltage from the drop in potential across a resistor connected in the negative H.T. lead; in such a position, in other words, that the anode current for all valves in the receiver flowed through it. This meant, of course, that the H.T. voltage available for the anode circuits of the set itself was reduced by the amount of voltage lost in the bias resistor.

It is not surprising, therefore, that a tradition seems to have grown up that the true H.T. voltage will be that available from the power supply unit, less the amount of bias required for the output valve. So far as the output valve itself is concerned, this will still be true, but it must be remembered that, with the modern type of self-biased circuit, where each individual valve is biased by the flow of its own anode current through a resistor, there is no loss of voltage, except in so far as the individual valve is concerned.

Imagine a power supply unit, delivering current at 280 volts under working conditions, and feeding a set with an output valve requiring 30 volts bias. The actual pressure available for this valve will therefore be only 250 volts, but the full 280 volts, less perhaps two or three volts

for bias, will still be applied to all the earlier valves, unless suitable means are taken to absorb some of them.

AS many builders of "H.F." sets have found out by bitter experience, the tendency towards uncontrollable self-oscillation is generally most marked at low wavelengths. On increasing the capacity of the tuning condenser of an unstable set, the unwanted oscillations become less and less strong until a point is reached—often at about 400 metres—where the receiver becomes completely stable.

### Unwanted Inter-circuit Couplings

AS most readers will be aware, the expression "modulation hum" is applied to a particular form of interference which manifests itself only when a carrier wave is being received. The trouble has of late been largely overcome by the fitting of a metallic shield between the primary and the various secondary sections of the power transformer used in A.C. mains sets.

### Screened Power Transformers

In order that this screen or shield may be entirely effective, it is a matter of considerable importance that care should be taken in the arrangement of the mains leads. These wires should never be passed in close proximity to the tuned circuits of the receiver or to the aerial; otherwise the transformer screen may be virtually short-circuited, as the interference may be induced directly into the circuits.

IT is perhaps fortunate that the commonest kind of fault to which fixed condensers are subject takes the form of a complete short-circuit between the two sets of plates or foils. Such a defect is easy to find; everyone knows that a fixed condenser *should* show a lack of continuity when tested with D.C. But there is another, and happily less common, fault which sometimes occurs, and which is very much harder to locate. Occasionally an internal disconnection will develop between a terminal and the plates; tested in the ordinary way, a condenser in which this defect exists will naturally show perfect insulation, but nevertheless will be quite useless.

A common test for both insulation and internal connections of large capacities is to charge the condenser by connecting it across a source of high tension D.C. voltage, and then to discharge it by bridging the terminals with a piece of metal. The production of a spark will indicate that everything is probably in order.

But this test is not applicable to small condensers, and for testing them thoroughly a pair of phones and a small dry battery are usually recommended.

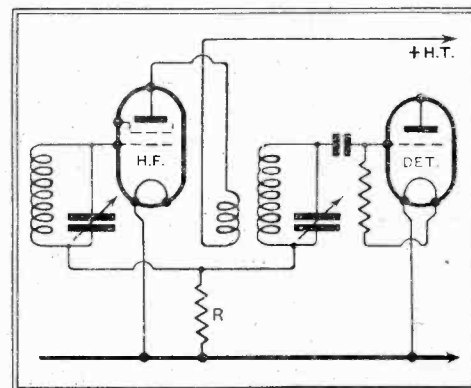

Fig. 1.—The resistance R represents an unwanted inter-circuit coupling, which might be introduced by a badly made earth connection on the ganged tuning condenser.

But occasionally partial instability manifests itself in the opposite way, and "patchy" self-oscillation will be encountered over a wide band of wavelengths between, perhaps, 400 and 500 metres. At lower wavelengths, and perhaps also at the extreme upper end of the wave range scale, there may be perfect stability.

It is useful to remember that effects of this latter kind are more often than not traceable to an unwanted resistance which is common to two or more oscillatory circuits. A badly earthed tuning condenser frame can, as mentioned last week, be responsible for instability; it may cause this trouble through high ohmic resistance in the earthing connection. The effect of this resistance will be understood by considering the skeleton circuit diagram reproduced in Fig. 1. In this diagram the resistance R, representing a high-resistance contact, is in series with the "return" leads of both the H.F. and detector grid circuits; the latter is, in effect, equivalent to the anode circuit of the H.F. valve, and so it is not hard to see that interaction of this nature may cause instability.



# How Europe Will Re-tune

Calibrating "By Numbers" on  
January 14th and 15th.

*TO avoid a repetition of the comparative chaos which followed the inauguration of the Prague Plan six years ago, the International Broadcasting Union has devised an elaborate system with which it is hoped to effect a smooth change-over to the Lucerne Plan in January next. This article describes the procedure at Zero Hour on the 14th*

It is now possible to reveal the arrangements under which the great change-over of wavelengths in accordance with the Lucerne plan will take place in January next. All European stations will cease transmission at or before 11 p.m., G.M.T., on January 14th, 1934. Then, one by one, according to special schedules now being prepared, the stations will resume broadcasting on their new wavelengths. These will be checked systematically by one or other of the ten official control points.

Immediately a control station has completed its measurements of the frequency of a transmitter, the fact will be announced over one of five high-powered stations specially selected by the International Broadcasting Union. This will

The master wavemeter at the Brussels control station. By this instrument all other European wavemeters are checked.

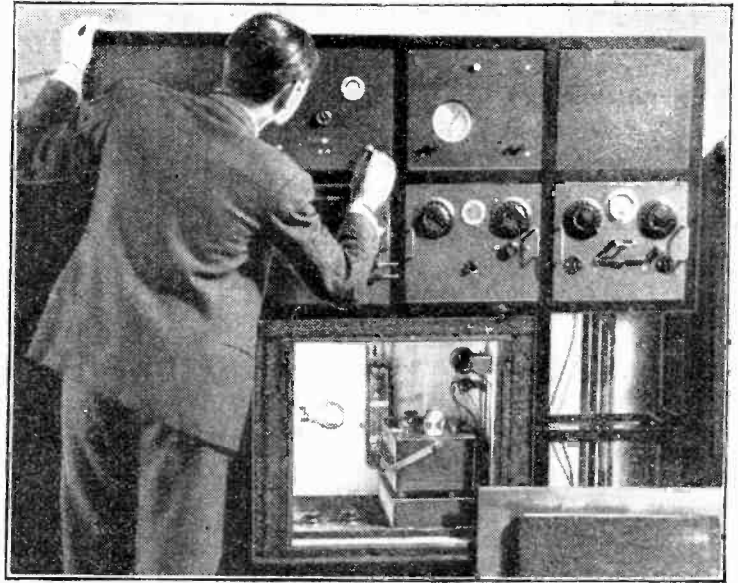

As can be seen from the accompanying map, Brussels will be the nerve-centre for the entire change-over.

By special arrangement made at the Amsterdam meeting of the International Broadcasting Union, the Postal Administrations will supply long-distance telephone lines, free of charge, for communication between the control points on the two nights of the change-over.

It may be wondered why each station will not change its wavelength by means of its own wavemeter, as was done previously when the Prague plan was introduced in 1927. However, bitter experience at that time showed that a much more rigid central control was necessary, especially as the majority of the stations in Europe have wavemeters of doubtful veracity. Moreover, it is much more effective to check the wavelength at a distance where interference with neighbouring stations can be more speedily detected than by station officials themselves.

Listeners who are prepared to sacrifice some sleep should have an excellent opportunity of calibrating their sets on the nights of January 14th and 15th.

In the following lists are shown the control stations and the countries whose transmitters they will check, and also the high-

power station announcing the results of the measurements:—

**Control Stations: BRUSSELS, TATSFIELD.** Stations to be checked: Belgium, Spain, France, Great Britain, Ireland, Iceland, Luxembourg, Morocco, Holland, Portugal, Switzerland. Station transmitting results of measurements: Radio Paris.

**Control station: BERLIN (REICHSPOST-ZENTRALAMT).** Stations to be checked: Germany, Denmark, Poland. Station transmitting results of measurements: Zeesen (Konigswusterhausen, Deutschlandsender).

**Control station: PRAGUE.** Stations to be checked: Austria, Hungary, Roumania, Czechoslovakia. Station transmitting results of measurements: Zeesen (Konigswusterhausen, Deutschlandsender).

**Control Station: HELSINKI (HELSINGFORS).** Stations to be checked: Estonia, Finland, Latvia, Lithuania. Station transmitting results of measurements: Lahti.

**Control station: MOJAIK.** Station to be checked: U.R.S.S. Station transmitting results of measurements: Moscow.

**Control station: SESTO CALENDE.** Stations to be checked: Italy, Turkey, Yugoslavia, Algeria, Tunis, Egypt. Station transmitting results of measurements: Rome.

**Control station: STOCKHOLM.** Stations to be checked: Sweden, Norway. Station transmitting results of measurement: Stockholm.

All these control stations will be interconnected by telephone. The use of the control stations at Berne (Switzerland) and Warsaw (Poland) will be made known at some later date.

British listeners tuning in Radio Paris after 11 p.m. will hear that station calling up various transmitters in turn in the eleven countries under the control of Brussels and Tatsfield. Similarly, they will hear Rome monitoring the transmitters in the south, while Zeesen superintends Central European transmitters.

"WANDERING WAVE."

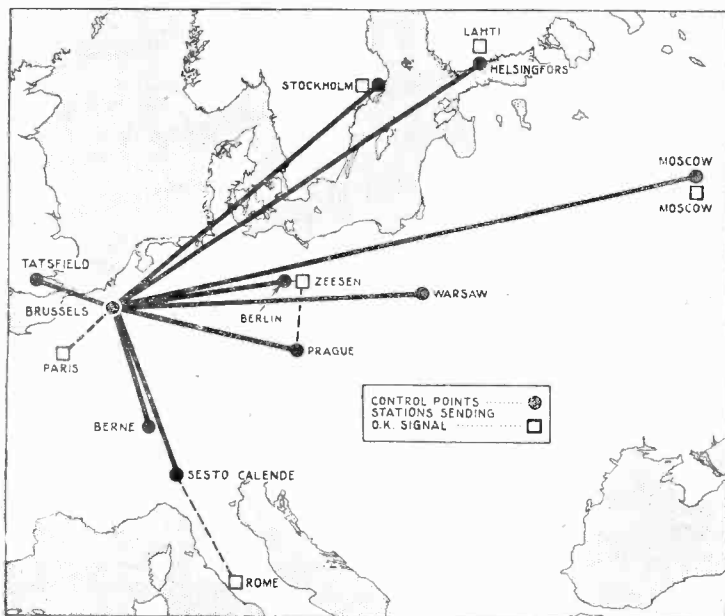

All European stations will close down at 11 p.m. (G.M.T.) on January 14th. Then stations in each of five main groups will resume transmission one by one on their new wavelengths. As the map indicates, Brussels will form the hub of the system.

be the medium of communication between the control stations and the transmitters.

To assist rapid identification, each transmitter will broadcast its name and country at least every two minutes during its transmission period. The transmissions will consist of gramophone records of which the titles will have been previously communicated to the control posts.



# Radio - gramophone Conversions

## Some Suggestions for Adding Record Playing to the Radio Receiver

**T**HERE is a growing tendency on the part of the public to prefer to listen both to broadcasting and to records at a considerable distance from the loud speaker. In the case of broadcasts, if a complete programme is being listened to it is a simple matter to tune in the set at one end of the room and then settle down in comfort at the other end to enjoy the entertainment undisturbed. When, however, we want to play gramophone records, unless we have the luxury of a record changer we have to jump up and change the record each time.

It is for this reason, probably, more than any other that the type of unit known as a playing desk is growing in popularity.

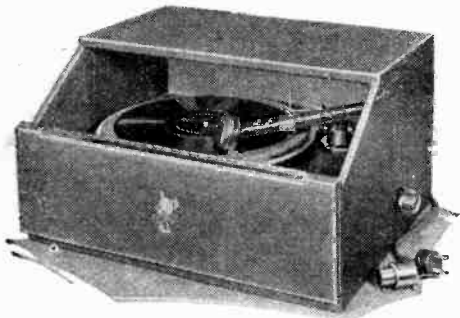

Junior Model Apollo Playing Desk.

Whilst the very practical reader would probably construct or assemble such a unit for himself, there are many who have not the inclination or facilities for doing so.

Fortunately, there is quite a choice of units ready-made which serve to convert the radio set into a radio-gramophone complete. That every wireless receiver is a potential radio-gramophone is evident by the now almost universal practice of fitting two terminals or sockets, marked "Gramophone Pick-up." These units are available in several different styles, and at prices to meet all pockets. They range from portable units to large cabinets in which is embodied the gramophone equipment, and only the addition of a receiver chassis is needed to give a fully-fledged radio-gramophone. Here, however, we trespass on the constructors' field, since a certain amount of dismantling and reassembling is involved.

### Fireside Models

The All-Electric Record Playing Unit of Bowyer-Lowe and A.E.D., Ltd., is a typical example of the portable pattern. In many respects it resembles a portable gramophone, but it is equipped with an electric motor, complete with automatic stop, pick-up, needle holders, and a graded volume control, and the price is £6 19s. 6d. Identical so far as its essential

*M*ANY requests are received as to how best to convert a modern radio set to a radio-gramophone. The purpose of this article is to direct attention to the variety of suitable units for this purpose available to those who do not wish to construct their own.

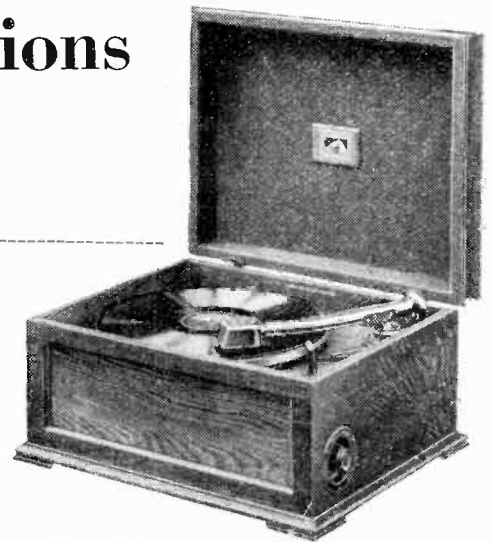

H.M.V. Model No. 116 Playing Desk.

features are concerned, but differing constructionally, is the H.M.V. Model 116 Playing Desk. This is very compact, and measures about 10in. high, and with just enough space to accommodate a 12in. record, and it sits conveniently on a chair or low table by the fireside. The fittings comprise an H.M.V. electric motor with automatic brake and switch, pick-up, volume control, and needle holders. Housed in an attractive oak case having a felt-lined lid, the price is seven guineas for either an A.C. or a D.C. model.

By so designing the gramophone unit that it serves as a stand, or plinth, for the radio set, brings us one stage nearer to a self-contained radio-gramophone, and examples of this style are to be found in Apollo Playing Desks, the C.A.C. Convertagram Playing Desk, the Harlie Fix-A-Gram, and the Univolt Electradio-Gram Unit in its cabinet forms. As several models in each make are available we



Harlie Fix-A-Gram Gramophone Unit.

might as well examine them in more detail, as doubtlessly many interesting features will come to light in the process.

Now, taking these in the order mentioned: Apollo Playing Desks are made in six different styles, of which four are table type and two bureau models. Models No. 1 and No. 2 are table walnut cabinets with a sliding front panel and space on top to stand the receiver. The first-mentioned includes an electric motor with automatic brake and switch, Apollo "Goldring" pick-up, volume control, and needle receptacles, and its price is £5 17s. Its companion is for battery users and includes a spring motor, the other fittings being the

same as in the mains version. With a single spring motor the price is £4 4s., and with a double spring one £4 12s. 6d.

A cheaper style, known as the Junior model, is now available for £4 17s. 6d. for mains supplies, or at £2 18s. 6d. with a spring motor. This is housed in a slightly smaller case, covered in brown leather cloth, with a hinged front. The equipment is as complete as the walnut cased models, and a Marconi Junior pick-up is fitted. All will accommodate 12in. records when fully closed.

Finally, there is the Bureau model, a handsome piece of furniture, measuring 30½in. x 19in. x 17½in., with an 18in. x 11½in. top for the set. These are made in walnut and oak, and range in price from eight guineas to £16 5s., the more expensive types being fitted with a Garrard automatic record changer. The lower cupboard affords storage space for eighty records, and A.C. and D.C. models are available.

The City Accumulator Co., Ltd., Convertagram Playing Desk is of the pedestal type, and made of figured walnut. The fittings in the standard model consist of a Collaro electric motor, automatic brake and stop, pick-up, and volume control. These are mounted on a shelf which automatically slides forward when the front is opened, thereby giving easy access to the turntable and the controls. It measures 30in. high, and the top is 18½in. x 16in., but these dimensions are elastic, and can easily be altered to suit individual requirements; likewise, the equipment and the woodwork can be made to comply to any desired specification. Indeed, the policy of this firm is to build to specification

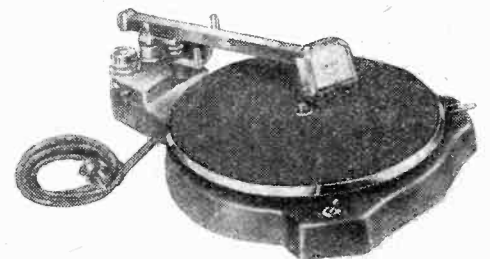

Univolt Electradio-Gram Unit.



**Radio-gramophone Conversion—**

rather than to market a stock model. The standard product as described costs £6 19s. 6d. complete, while the cabinet alone can be purchased for £2 19s. 6d.

The Harlie Fix-A-Gram is a table model measuring 9in. high, the top, on which rests the receiver, being 16in. wide × 13in. deep. Its equipment comprises electric motor with automatic stop, pick-up, and volume control; these are assembled on a shelf which slides forward by the action of opening the front. Fitted with an A.C. motor it costs £5 15s. in a polished walnut cabinet. An exact duplicate, but with a double spring motor for battery set users, is available at £4 19s.

**Conventional Cabinets**

One of the outstanding features of the Univolt Electradox-Gram Unit is its remarkable compactness. Yet it is complete in every detail and embodies an electric motor with automatic stop, volume control and a mains master switch, the whole within the small compass of 14½in. × 10½in. × 2in. deep. And the price is £4 5s. Two cabinets of the pedestal type have been designed by the makers to house this unit and serve, also, as a stand for the wireless set. The unit is mounted on a pull-out shelf with a front resembling a drawer, and the whole forms a very attractive assemblage. The Pedestal Radio-Gram cabinet

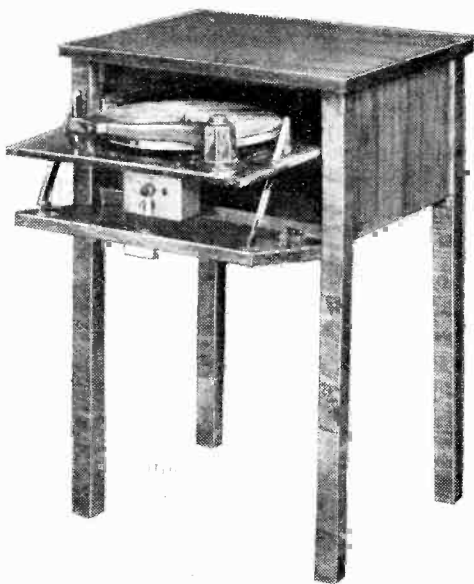

C.A.C. Converta-gram Playing Desk.

costs £6 15s., the other model is priced at £7 17s. 6d., and includes a spacious record cupboard.

In the foregoing the receiver and gramophone unit have retained their respective characteristics while yet offering all the facilities of a radio-gramophone. Indeed, it is only our accepted conception of this dual-purpose instrument, assuming, as it does, a cabinet of particular form, that precludes styling the composite apparatus a radio-gramophone, although in actual fact it has now attained this status. Only the mantle is necessary to complete the metamorphosis, but sundry constructional alterations will be involved. Nevertheless,

some may be prepared to consider this change, in which case the Adaptagram cabinet made by the Peto-Scott Co., Ltd., will greatly facilitate the work. For this cabinet is available with the gramophone equipment ready assembled, and only the addition of the receiver chassis is needed to complete it. Fitted with a double-spring motor, pick-up, volume control and all other accessories, it costs six guineas in walnut, while for one guinea more it can be supplied fitted with an A.C. motor. Still a further model is available, and this embodies a Class "B" amplifier in addition to full gramophone equipment and a permanent magnet moving-coil loud speaker, and the price is £9 5s. The cabinet alone can be obtained for three guineas.

This résumé would not be complete without a reference to radio-gramophone cabinets since every modern receiver constructed in chassis form is readily convertible into a radio-gram. It must suffice, however, to say that cabinets of this type can be obtained from the Carington Manufacturing Co., Ltd., C. A. Osborn, City Accumulator Co., Ltd., Dal-low Manufacturing Co., Ltd., W. and T. Lock, Ltd., and F. Digby.

Peto-Scott  
Adaptagram  
inlaid walnut  
cabinet.

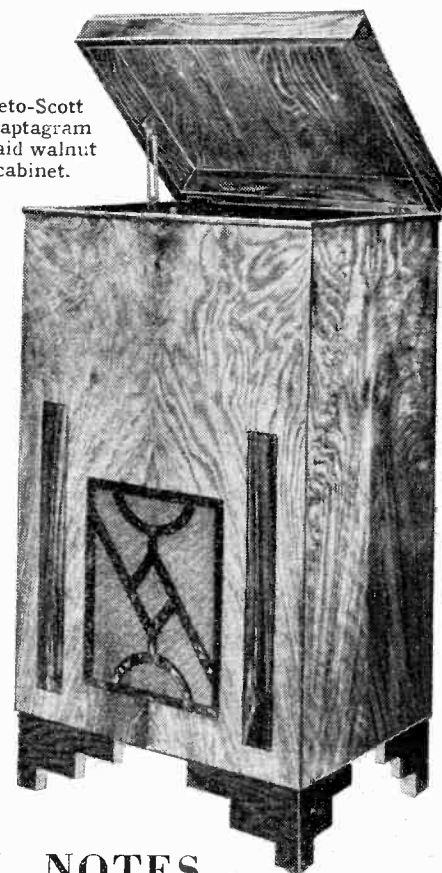
**DISTANT RECEPTION NOTES****New German 100kW Station**

IT was reported recently that an aeroplane had flown into Berlin Witzleben's aerial wires. The pilot fortunately escaped uninjured, but the same cannot be said of the 'plane or the aerial. Perhaps that is why nothing has been heard of the Berlin station for some little time now. Since every effort is being concentrated on getting the new station at Tegel completed, there is probably no time to spare for making a proper repair of the old aerial.

The new 100-kilowatt station at Tegel will probably be transmitting by the time that this note appears in print. It will work on 360.6 metres, thus becoming London Regional's next door neighbour in place of Mühlacker.

Stuttgart, still using the old 1.5-kilowatt plant, will then move to 533 metres, and Munich, also on low power for the time being, will transmit on 419.5 metres.

The object of this reshuffle is to enable the three stations to work as close as possible to the wavelengths that they will have after January 15th. When the Lucerne Plan comes into force Berlin goes to 356.7 metres, Munich to 405.4 metres, and Mühlacker to 522.6 metres.

As soon as Berlin is working at full power the business of separating this station from the London Regional may be rather easier with a highly selective set than was that of obtaining Mühlacker clear of interference. The reason is that owing to the increased power of the Berlin station it should lead to rather greater field strength in this country, though Berlin is about one hundred miles farther from London than Stuttgart.

Short-wave reception is better worth while at present than it has been for a long time. One aspect of this kind of very long-distance listening that will appeal to many enthusiasts is that there is no need to sit up

beyond one's normal bedtime in order to make a good bag of stations. From dusk to about 9 p.m. stations with wavelengths below 20 metres have been wonderfully good of late. W2XAD on 19.56 metres and W8XK on 19.72 metres are outstanding early-evening signals. W8XK also conducts an afternoon transmission on 13.93 metres. This has not been receivable for a long time until lately, but now it is coming in again. VK2ME, the 31.55-metre Melbourne station, has also been well received in the afternoons on several recent occasions.

Of the European long-wave stations Huizen is now completely ruined by interference on, or almost on, the same wavelength, and Luxembourg is again heterodyned. Kalundborg, however, is free of interference from Monte Ceneri, and with a selective receiving set both stations are receivable. Radio-Paris, Zeesen, Warsaw, Motala and Oslo can all be relied upon for good reception. Both Vienna and Budapest are coming in wonderfully well. We should obtain magnificent reception from them when Vienna's second mast is completed and Budapest's new transmitter comes into action.

I don't know whether other readers have tuned over the medium waveband lately between four and five o'clock in the afternoon. If they have not, they may obtain a surprise when they do so. On the afternoon when these notes were written a four-valve receiver brought in Brussels No. 2, Langenberg, Beromünster, Stockholm, Leipzig, Strasbourg, Breslau, Göteborg, Hilversum, Heilsberg, Turin, Hörby and Nürnberg, all at good loud speaker strength.

In addition to the stations mentioned, Rome, Prague, Hamburg, Milan and Trieste provide good and reliable reception.

"D. EXER."



# NEWS of the WEEK

## Current Events in Brief Review

### Radio-Paris

RADIO-PARIS is now officially a State station. Programmes are arranged by members of the original management in collaboration with the Post Office.

### The English Flavour

LISTEN to the announcements by the "speakerine" of the Radio-Côte d'Azur station. Listeners state that her French is spoken with an English accent, due to the fact that the speaker, Mlle. Leo Baillet, was brought up in England.

### Believe It or Not

THE cigar-box receiver, which has been a sensation for so many years, has received the *coup-de-grâce* in Marseilles with the invention of the "cigar set" or super-midget, which, when lit up, receives all European stations. According to the report—and who dare doubt it?—the hyper-Lilliputian speaker forms the cover of a tiny goblet containing a cocktail.

### Marconi and the Amateur

MARCHESE MARCONI has caused delight among the American amateur fraternity by a happy incident which occurred just after his recent visit to the Chicago World's Fair. At 11 p.m., when the Marchese's party were preparing to return to their hotel, the inventor suddenly said: "I hear that there is an amateur station in the Fair. I want to go and see it." There and then the Marchese proceeded in his big Cadillac to the building where the American Radio Relay League operated an amateur station.

The two operators on duty

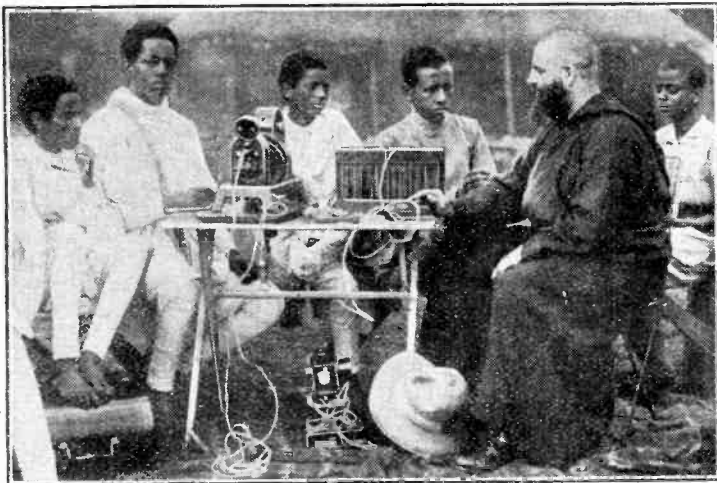

**DOTS AND DASHES IN ETHIOPIA.** Father Esuyen, a French Capuchin monk, who has opened a school in Abyssinia for budding wireless operators, who are prepared for the Government examinations.

failed to recognise their distinguished visitor, but he at once introduced himself. After inspecting the equipment carefully he remarked that it was a very fine piece of workmanship. The proud builder deprecated his efforts, saying: "But it was built by only an amateur."

"Ah," said the Marchese, "I am only an amateur myself."

### Hughes Medallist

PROFESSOR E. V. APPLETON has been awarded the Hughes Medal by the Royal Society for his researches into the effect of the Heaviside Layer upon the transmission of wireless signals.

Professor Appleton's researches at King's College, London, led to the discovery of a second "Heaviside Layer," often known as the Appleton Layer, above the one already known. He is forty-one, and became an F.R.S. at the age of thirty-five.

### Lady Amateur Loses Licence

TO Mrs. Doris Melanson, of Station WIFSM, Belmont, Mass., belongs the melancholy distinction of being the first American lady radio amateur to lose her licence. The licence has been revoked by the Federal Radio Commission on the grounds that the lady's husband is a citizen of Canada, and the radio law specifically forbids the operation of a transmitter on the property of an alien. Unhappily, too, it is said that Mr. Melanson pleaded guilty to a conspiracy to violate the liquor laws.

The dice seems to have been heavily loaded against Mrs. Melanson.

### Tourists' Radio in Italy

TOURISTS may now take portable wireless sets into Italy free of duty for a period of three months. A special wireless licence is available for this period at a fee of lire 15 (about five shillings), which is issued by the Italian Broadcasting Company.

### Pirates' Paradise

YUGO-SLAVIA is a great stronghold of radio pirates, and, according to the Belgrade Radio Company, they are equal in numerical strength to the licensed listeners. The licence fee is 300 dinards per annum or 25 dinards (about two shillings) a month.

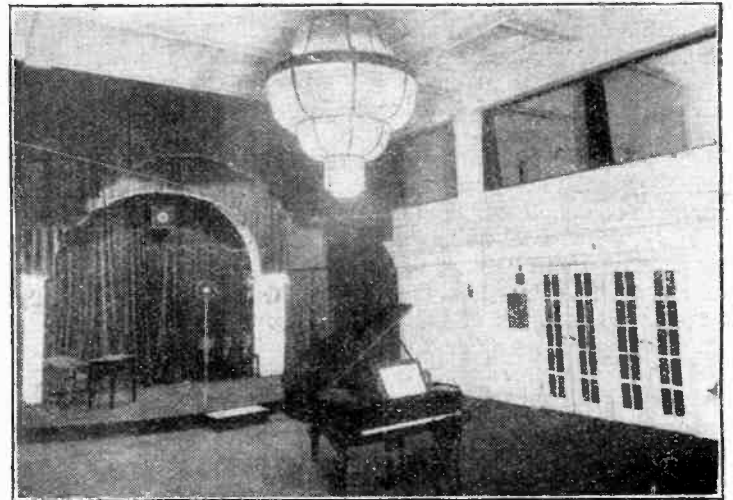

**SCHUBERT CELEBRATIONS AT WARSAW.** The main studio at Polskie Radio. From here on Sunday next, at 11.5 a.m., the Philharmonic Orchestra will broadcast a concert commemorating the 105th anniversary of Schubert's death.

Up till now, no action has been taken to enforce payment of licence fees.

Many listeners refuse to pay on account of the interference caused by the Italian military Alpine transmitters on the Italian-Yugo-Slavian border. Interference is most marked on the transmissions of Ljubljana, the station of the famous "cuckoo call."

### A World Beater

THE letters "WBE" after the name of an amateur indicate that he holds the Radio Society of Great Britain's certificate for telephony, the condition being that he shall have communicated by telephony with a station situated in a British possession in each continent of the world. This distinction has been won by Mr. Frank R. Neill (G15NJ), of Whitehead, Belfast, who is understood to be the second amateur to have secured this honour. He also holds the WAC (worked all Continents) certificate for telephony, and both the WBE and WAC certificates for C.V. He is believed to be the only person in the world holding all four certificates.

### State-aided Trade

THE Belgian "Minister of Public Instruction" has ordered all teachers to procure wireless sets and listen regularly to the programmes. Commenting on this fiat, a French contemporary wishes that the Ministers of Transport and Marine would follow suit, as this would boost up the sales of motor cars and motor boats.

### Zagreb Power Increase

A NEW 20-kW. station is being built at Zagreb, Yugo-Slavia, to replace the existing 0.75-kW. transmitter.

### R.N.W.A.R. Dinner

SIXTY-FOUR members from all parts of the country were present at the First Annual Dinner of the Royal Naval Wireless Auxiliary Reserve held at Pinoli's Restaurant, Wardour Street, on October 28th. Chief Officer Glastonbury, R.N., replying to the toast of "The Visitors," drew

attention to the rapidly growing efficiency of "Britain's Youngest Reserve."

### 128 Kilowatts from Bergen

A NEW broadcast transmitter is to be erected at Bergen with a power of 128 kW. in the aerial. The station is to be built by the Marconi Company.

### Grave and Gay

THE unhappy incongruities which sometimes attach to radio advertising were again illustrated by one of the private broadcasting stations in Paris the other day. A news item describing how a man in a state of drunkenness had murdered his wife was immediately followed by an advertisement opening with the boisterous slogan, "Drink wine and live happy!"

### The Cautious President

PRESIDENT ROOSEVELT'S broadcasts, it has been decided, must be limited in number if his more momentous pronouncements over the microphone are to be given their proper valuation.

It is suspected that both President Hoover and the late President Coolidge were too generous in according facilities to the broadcasting networks, with the consequence that presidential speeches ceased to be "star" items. In seven years President Coolidge broadcast thirty-seven times, while President Hoover, during his four years in office, was heard no fewer than ninety-eight times.

### In the West Country

THE listening habit is growing in the West Country, where licence numbers show a steady increase. At the end of September there were 103,932 licences in existence in Devon; Cornwall returned 29,798 licences, Somerset 54,634, and Dorset 21,286. The total monthly increase in the four counties was nearly 2,500.



# Broadcast Brevities

By Our Special Correspondent

## The New Birmingham Studios

ALTHOUGH, technically speaking, the new studios at Broad Street, Birmingham, are not entirely completed, they are now in regular use. They are lofty windowless rooms, ventilated by suction, heated by radiators, and decorated in the best modern traditions of Broadcasting House.

The principal studio, No. 4, measures 46ft. by 38ft. and is 21ft. high at the loftiest point of the curved ceiling. There is concealed lighting and two spot lights. At a recent orchestral concert the studio accommodated forty-nine players and the conductor.

## From the Director's Room

Small orchestra concerts, plays, children's programmes are broadcast from No. 2 studio on the top floor. Other studios serve for talks, effects, and children's hours.

Strangely enough, the more distinguished visitors do not speak from a talks studio, but are privileged to address the microphone in the Regional-Director's room.

## Gratitude

I MET John MacDonnell, in the main entrance to Broadcasting House, staggering under the weight of a bulging parcel of congratulatory correspondence, apropos that most successful production of his, "Good Evening."

MacDonnell's programmes seem to evoke an unusual quality of gratitude among his listeners, for he told me that parcels had been arriving filled with such good things as jellied chicken, apples, pears, nuts of every description, not to mention several pairs of kippers.

## Severe Strain

No other broadcaster prompts such gifts. No wonder MacDonnell is "overwhelmed," as he put it. Broadcasting can impose severe strains on the constitution.

## Strange Clash

ON several recent occasions, when listening to London National, I have heard a faint background of speech or music broadcast from the Regional transmitter. My set, a "Wireless World Ferrocarril III," cuts out both stations within a fraction of a degree. The B.C.C. engineers inform me that induction between the lines in the control room or at Brookmans Park is of the rarest occurrence. Can there be any other solution of the mystery?

If other readers have experienced the same trouble I should be very glad to hear their comments.

## No Fuss

NO great misery has been occasioned by the synchronisation between London and West National. Indeed, the total number of reports of "wavering" has been only thirty-two, of which only four came from the London area.

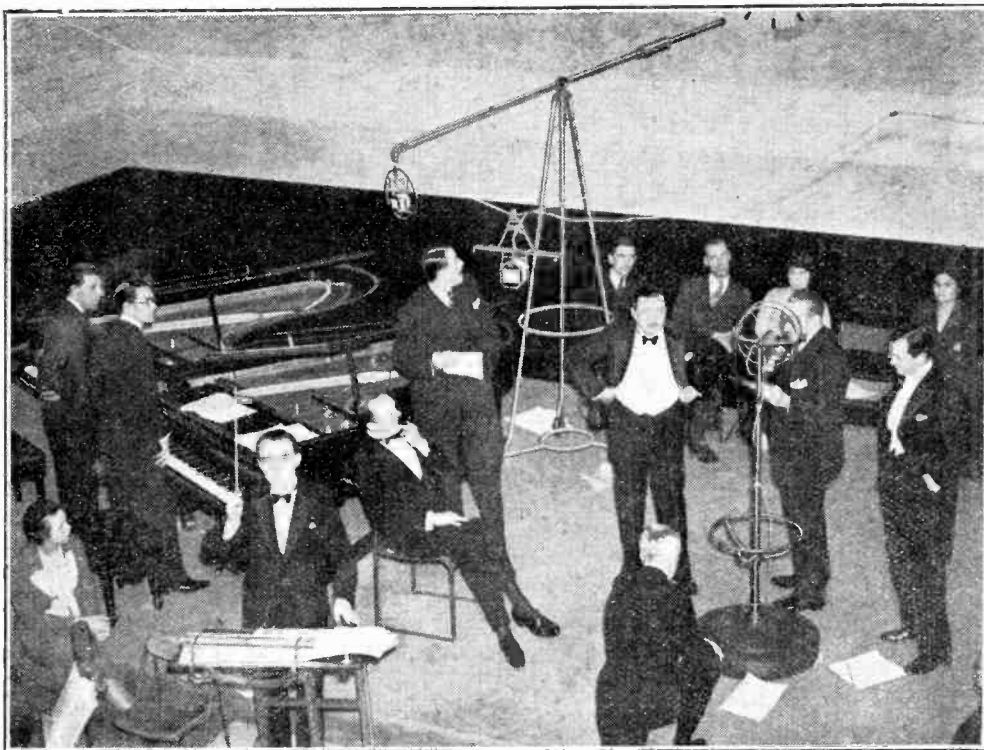

THE CAMERA IN THE STUDIO. A striking photograph taken at Broadcasting House last week during the actual transmission of "Good Evening." John MacDonnell, producer, is to the left of the microphone, while Christopher Stone introduces Bobby Howes (right) to the listening public.

## Deceiving the Public

IS the B.B.C. guilty of a breach of faith when the voices of eminent artistes are broadcast without any announcement that a gramophone record is being used? A pretty question, much easier to ask than to answer.

At all events, the thing is done, and done often, but only in one case, so far as I am aware, has a deliberate attempt been made to persuade listeners that they were hearing an actual "flesh and blood" effort by the artiste in question.

## The Facts

This was during that very successful programme, "C. B. Cochran Presents," when everything was done and said to indicate that the listener was being switched through to the actress's dressing-room at the Adelphi Theatre between acts. The little trick was successfully carried out, but the real truth was that, far from being hurried and harried by the importunate call boy whom we heard in the background, Miss Gertrude Lawrence recorded her staccato greetings comfortably and quietly two days before.

## "Good Night, Vienna."

AFTER nearly two years, Holt Marvell's romantic operetta "Good Night, Vienna" returns to the microphone on December 6th (Regional) and December 7th (National). The music is by George Posford, while Val Gielgud, the B.B.C.'s Director of Drama, will act as producer.

"Good Night, Vienna" requires eleven studios. It has already made a very successful film; indeed, it was this piece that showed the affinity between broadcast technique and that of the screen.

## Variety on Trial

A MOCK trial in which "Radio Variety" will be in the box is to be featured by Rex Evans in his next "Merry-go-round" programme on November 26th. Each act in turn will enter the witness box and plead his own defence. Evans will be judge.

The Cause list contains such names as John Tilley, Jeanne de Casalis, Elizabeth Pollock, and Elizabeth Welch, now appearing in "Nymph Errant."

## Future Features

"THE Three Musketeers" will be broadcast in December.

The Café Colette orchestra, whose origin—Paris, Brussels, Vienna or Marseilles?—no one knows, will make a public appearance at the St. George's Hall in a "Music Hall Broadcast" on November 25th.

From Bombay on December 13th a special programme will be relayed to British listeners, thanks to the co-operation of the Indian State Broadcasting Service. Items will include Indian vocal and instrumental music by native artistes, a commentary on a typical street scene in Bombay, and greetings to the Home country.

An eye-witness account of the International Association Football match between Scotland and Austria will be broadcast from the Glasgow studio on November 29th.

November 30th, St. Andrew's Day, is to be celebrated at Scottish Broadcasting House in grand style.

## Every Day a Flag Day

IT is only right that Admiral Sir Charles Cyprien should be in charge of the flags at Broadcasting House. This business of flying the right flag at the right time grows more onerous from day to day. Distinguished visitors drop in at any old time, and sometimes Sir Charles must despatch his lieutenants to the nearest flag shop at a moment's notice.

## Flags to Order

Flags in stock include the Royal Standard, the Union Jack, the Stars and Stripes, the B.B.C. House Flag, and one or two miscellaneous emblems for dull days.



# UNBIASED

## BY FREE GRID

### Tripe and Onions

RECENTLY I was called in by a wretched cousin of mine to investigate a mysterious form of interference which afflicted all the receivers in her suburban neighbourhood from about 6.30 to 7 on certain evenings. I was fortunate, inasmuch that the interference appeared on the very first evening on which I listened

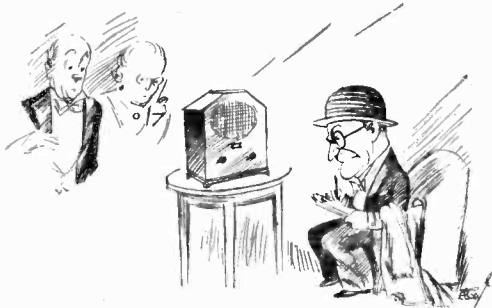

T-R-I-P-E A-N-D O-N-I-O-N-S.

for it. At once I recognised it to be a morse message, obviously emanating from some form of spark transmitter and containing a mysterious demand for "two pairs of kippers," repeated over and over again.

Two evenings went by without any further messages, and then came a peremptory demand for tripe and onions, repeated for upwards of half-an-hour. From time to time other requests of a like nature have been made in the same manner, but I must confess that I am at present completely baffled and no nearer the solution than when I first commenced to investigate the mystery.

Unless I receive helpful suggestions from clever but kind-hearted readers I fear that I shall have to confess myself beaten, a thing which I am naturally very loath to do, as it will mean a considerable loss of prestige in the eyes of my cousin.

### Gas Manager's Troubles—III

THOSE readers who were reading these notes as long ago as last winter and who, like Mr. Micawber, are still desperately hanging on in the hope that something better will turn up, may probably remember that in the first 1933 issue of this journal I related the radio troubles of an unfortunate gas manager in a certain provincial town. It will be remembered that he was denied the benefits of a mains set owing to the fact that his narrow-minded directors refused to countenance the presence of electric light in his house.

Being old and well stricken in years, quite apart from the fact that he was fed up with the action of his company, he has, since that date, quite properly decided to put radio before everything else, and so has retired.

After the finish of the Cambridgeshire the other day I took a brisk walk over to his new house. It was a distinctly modern dwelling, but to my surprise it contained old-fashioned gasoliers.

I was still more astonished, however, when, after lighting the gas with a match in the usual way, my friend told me in confidence that actually electric light *was* used, but that everything had been designed to make it look like gas lighting. There was even the necessity of using a match, and the presence of miniature electric light bulbs of high candle power with gas mantles draped over them.

I frankly confessed to him that I thought the use of a match was all eye-wash and that actually the turning of a gas tap operated an electric switch. In reply he invited me to try to light up without a match, and I found that I could not do so; even when I did hold the necessary match to the inverted gas fitting, and the light suddenly came on, I frankly did not see how it worked.

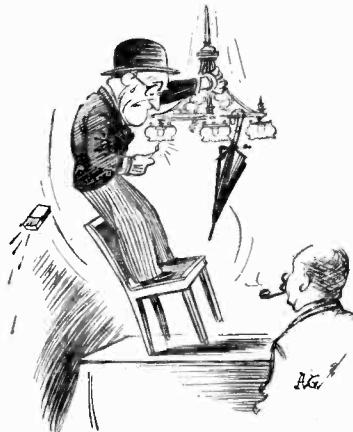

Invited me to try.

Explanations were soon forthcoming, and such a tale of misplaced ingenuity was unfolded to me as I have seldom met in a somewhat wide experience of this world and its wicked ways. He had, he explained, considered the question of using the tap as a switch, and, indeed, such it was; but, fearful of being unmasked in a moment of forgetfulness by lighting up without a match, he had included in series with it a miniature thermal delay switch, which was heated by the match. Once the light was on, there was, of course, sufficient heat developed to hold the switch over until the "gas" was turned off by the tap.

He explained to me that, after spending so many years of his life in urging his fellow citizens to use gas, he felt that he could not be so callous as to let them see that he really preferred electricity himself, and so he had done his best to keep up the illusion. Once again, I thought, "conscience doth make cowards of us all."

### My Radio Course for Pinheads—I

ONE of the most important components of a wireless installation is the aerial pole, for without it we should all be compelled to stand out in the garden and hold the aerial up ourselves whenever we wish to receive anything, and on these chilly winter evenings that would never do, would it?

Choosing an aerial pole is an even more important task than choosing a receiver, and in order to carry it out properly we should go to a builder's yard. Here there will usually be found a whole pile of them, resting after their fatiguing task of holding up the house until the wallpaper is put on, which is their normal avocation. As a consequence of the tiring nature of their workaday lives, some of them will be curved, i.e., not quite perpendicular or "straight," as the best people say. Since nothing that is not quite straight and above board must be tolerated in the matter of wireless, we must take great care how we choose our pole.

We must drop down on our hands and knees and squint along each pole to see how far each one has strayed from the path of rectitude; and what one of us has not strayed at one time or another, even if it be only the teeniest, teeniest bit?

Having made our choice, the kind-hearted builder's-foreman will immediately lend us a clothes brush, for we shall have soiled our trousers somewhat, shall we not? We can now return home to a nice hot tea, filled with that inward glow which alone comes of the consciousness of a good deed well done.

P.S.—If you find the above instructions too difficult, don't hesitate to write and tell me so, or rather write to the Editor, and he will pass the word on to the world-famed technical engineers whom he employs in his great research laboratories for the express purpose of elucidating



Choosing the Rod, Pole or Perch.

these problems for you. They will then be able, after years of patient research, to discover a simpler method for you to carry out this exacting task. But remember the old school motto and never give up.



# Television Explained

## IV.—The Requirements for a Good Image

THE fundamental methods of television transmission and reception have been explained in the preceding articles of this series, and with some knowledge of how the apparatus functions we can now consider the requirements for good results. There are two things which we must first decide—the picture frequency and the number of scanning lines. The greater the number of pictures transmitted a second the less likely we are to be troubled by flicker, and cinema practice tells us that we need not go above about twenty-four pictures a second for practically perfect results. The greater the number of scanning lines used the better will be the definition and detail.

Now the higher the picture frequency and the more lines used the higher will be the modulation frequencies required in the transmitter and the greater will be its sideband spread. It is here that the greatest practical difficulty is to be found, and so the first step is to determine the highest frequency required. Let us suppose that we wish to transmit a chessboard in which the black and white squares are the same size as the hole in the scanning disc or its equivalent. The variations in light and shade for a single scanning line are shown at (a) in Fig. 1, and the corresponding photo-cell current of the type shown at (b). In this particular case eighteen squares are shown of which nine are black and nine are white. There are, therefore, eighteen changes in the value of current through the cell. This current, however, may be regarded as an alternating current superimposed upon a steady direct current, as shown at (c), in which the line AB represents the steady current for this type of picture. It will be seen that one complete alternation of current occupies the time from X to Y, and for eighteen squares there are nine such alternations.

### Maximum Modulation Frequency

If the whole picture is a chessboard such as this, therefore, we might say that the maximum frequency required is equal to the number of pictures a second multiplied by one-half of the total number of squares. Now a high quality half-tone block will have a screen of perhaps 100,

corresponding to 10,000 elements per square inch. If the size of the picture be 5in. by 6in., its area is 30 sq. in., and with a screen of 100 there will be a total of 300,000 picture elements. In a television transmission, one-half of this number multiplied by a picture frequency of 25 leads to a maximum modulation frequency in the transmitter of 3,750,000 cycles. The transmitter sideband spread, therefore, would be 7,500,000 cycles.

A telephony transmitter of roughly

equal quality would require a total sideband spread of no more than 20,000 cycles, so that a single television transmitter would occupy as much space in the ether as 375 telephony transmitters. Moreover, transmission could not be carried out at all on frequencies below 3,750,000 cycles, or wavelengths above 80 metres.

In practice, the highest frequency required is not so readily calculated, for the picture is not divided into a definite number of elements as in the case of a half-tone block. The maximum frequency is dependent upon the maximum rate of change of light, and this in turn depends upon the type of picture being transmitted. If the picture contains strong black and white contrast with a sharp dividing line, the frequencies needed will be higher than if it is delicately shaded with the whites merging gradually into the blacks.

### Present Transmissions

The chessboard pattern which we have assumed is one requiring the highest frequencies, and represents the worst possible case. Even so, the frequencies required are likely to be as much as three times those calculated above on account of the presence of a strong third harmonic in the photo-cell current.

The present B.B.C. transmissions fall far below this ideal, of course, for there are only 30 lines and  $12\frac{1}{2}$  pictures a second. The ratio of height to breadth of the picture is 7:3, so that if we take the condition of the transmission of a chessboard 70 squares in height by 30 squares in width, the fundamental maximum frequency will be  $12\frac{1}{2} \times 70 \times 30 / 2 = 14,100$  cycles. It is believed that the maximum frequency transmitted at pre-

ONE of the chief difficulties found in television development is the enormous sideband spread of the transmitter, for a single television station may occupy as much space in the ether as sixty telephony transmitters. The reasons for this are explained in this article, and it is pointed out that the future of television lies in the ultra-short waveband.

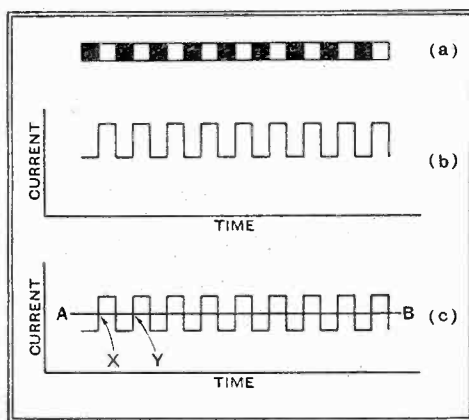

Fig. 1.—A series of black and white squares (a) gives rise to a photo-cell current of the type shown at (b). This is equivalent to a direct current, represented by AB in (c), with a superimposed alternating current.

sent is in the neighbourhood of 13,000 cycles. It is evident, therefore, that the present transmissions could just deal with a chessboard of the type described, provided that the photo-cell current involved no harmonics. As the current will always include harmonics, they will be absent in the receiver and the image will not show the sharp dividing lines between the squares which are characteristic of a chessboard, but the white and black squares will merge into one another through shaded areas.

One would expect, therefore, on these theoretical grounds that the present transmissions would be of little practical value. This is not so, however, for the reason that as severe a test as a chessboard rarely occurs in practice. Whatever the area of the objects involved, a sudden change from black to white necessitates equally high frequencies, but as in the practical case these sudden changes occur less frequently, the defects are correspondingly less noticeable.

### A Practical Compromise

At the present time perfection appears almost impossible, and it is necessary to decide the maximum modulation frequency that can be used in practice and the minimum frequency which will give an acceptable performance with real enter-



The fact that the photo-cell current does not change instantaneously leads to a blurring of the received image which is accentuated by a loss of extremely high frequencies. This is well brought out in this illustration.

**Television Explained—**

tainment value. This is hardly a matter which can be decided at present, but the writer has seen pictures with a ratio of height to breadth of 5:6 transmitted with a picture frequency of 25 and with 120 lines, and in his opinion there can be no doubt of the entertainment value of such an arrangement. The results are far from perfection, of course, but they are so good that it is easily possible to forget that the picture is televised and to lose oneself in the programme. A system of this nature involves frequencies of  $25 \times 144 \times 120/2 = 126,000$  cycles, and, taking into account the inevitable harmonics, frequencies up to 300 kc/s are needed.

The lowest frequency required is a matter of some importance, but in general this need not be below the picture frequency. With the B.B.C. transmissions, therefore, the receiver must operate over the range of  $12\frac{1}{2}$  to 13,000 cycles, and with the really high quality system from 25 cycles to 300,000 cycles.

It will be immediately apparent that the design of a low-frequency amplifier to

cover the latter range is a matter of no little difficulty, particularly as phase distortion is a matter of some importance. L.F. transformers, of course, are ruled out, and it is usual to employ resistance-capacity coupling modified by the inclusion of corrective networks to compensate for the inevitable high note loss due to stray capacities.

In transmission, however, the presence of modulation frequencies up to 300,000 cycles leads to difficulties owing to the sideband spread of the transmitter, for a single station will occupy as much space as sixty present-day broadcasting stations. It is apparent, therefore, that television transmitters of this type can only work on the ultra-short wavelengths around 5 metres; there is no room for them anywhere else.

It is probably this question of the high modulation frequencies involved that has limited the growth of television more than anything else. High quality television will not appear until the technique of transmission and reception on 5 metres is more fully developed.

***In Next Week's Issue:—***

“The Wireless World”

**A.V.C. STRAIGHT FOUR**

An A.C. Mains Quality Set for the Critical Ear

**I**N spite of the popularity of the superheterodyne the straight set still retains many adherents, and its disadvantage of poorer selectivity has been largely removed by the development of iron-core coils of high efficiency. The selectivity of a set fitted with four tuned circuits and two H.F. stages, therefore, now closely

cascade circuits to avoid a loss of the upper audible frequencies.

A duo-diode-pentode valve acts as the detector and the L.F. stage, while providing automatic volume control operative on the two H.F. valves and the L.F. sec-

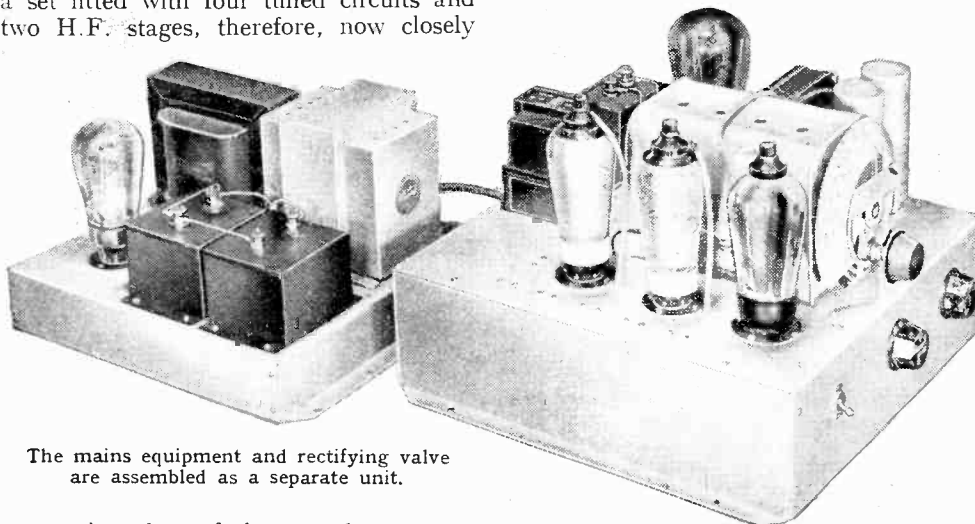

The mains equipment and rectifying valve are assembled as a separate unit.

approaches that of the superheterodyne.

Advantage has been taken of this development, therefore, in designing the A.V.C. Straight Four, and the two variable-mu H.F. pentodes which provide the H.F. amplification are associated with four iron-cored coils which are so tapped that optimum selectivity is obtained. The tuning system is a combination of band-pass and

tion of the duo-diode-pentode. The coupling to the output valve, which is of the 25-watts type capable of delivering nearly 6 watts to the speaker, is by means of a high-grade transformer.

Constructionally, an assemblage on metal chassis is adopted in the case of both receiver and power units, thus greatly

**A.V.C. STRAIGHT FOUR****THE LIST OF PARTS.****Receiver Unit**

- 1 4-gang condenser Polar "Star Minor"
- 1 Dial for above Polar "Full-Vision" Semicircular Drive
- 1 Set of 4 Ferrocarril coils on chassis, consisting of F.10, F.11, F.12 and F.13 Colvern
- 3 Screened H.F. chokes Bulgin H.F.9
- 2 Electrolytic condensers, 8 mfd., 450 volts peak working Dubilier
- (Peak, T.C.C.)
- 1 Fixed condenser, 2 mfd., 550 volts, D.C. working, in rectangular metal container Dubilier L.C.G.
- 1 Fixed condenser, non-inductive, 2 mfd., 250 volts, D.C. working, in cylindrical aluminium container Dubilier 9200
- 2 Fixed condensers, non-inductive, 1 mfd., 250 volts, D.C. working, in cylindrical aluminium containers Dubilier 9200
- 7 Fixed condensers, non-inductive, 0.1 mfd., 250 volts, D.C. working, in cylindrical aluminium containers Dubilier 9200
- 1 Resistor, 30 ohms Claude Lyons "Humdinger"
- 1 Wire-wound resistance, 7,500 ohms, 20 watts Bu'gin PR.10
- 1 Resistance, 100 ohms, 1 watt Erie
- 1 Resistance, 500 ohms, 1 watt Erie
- 1 Resistance, 500 ohms, 3 watts Erie
- 2 Resistances, 600 ohms, 1 watt Erie
- 2 Resistances, 1,000 ohms, 1 watt Erie
- 1 Resistance, 2,000 ohms, 1 watt Erie
- 1 Resistance, 5,000 ohms, 1 watt Erie
- 1 Resistance, 10,000 ohms, 1 watt Erie
- 2 Resistances, 20,000 ohms, 1 watt Erie
- 1 Resistance, 50,000 ohms, 1 watt Erie
- 1 Resistance, 500,000 ohms, 1 watt Erie
- 1 Resistance, 1 megohm Erie
- 3 Resistances, 2 megohms Erie
- (Dubilier, Graham Farish, Claude Lyons, Seradex.)
- 1 Tapered volume control, 250,000 ohms Magnum
- (Claude Lyons, Watmel.)
- 1 L.F. transformer, 1.34 Ferranti AF5
- 1 L.F. choke, 20 henrys, 60 mA. R.I. DY51
- 4 Valve holders, 5-pin Clix Chassis Mounting Standard Model
- 1 Valve holder, 7-pin Clix Chassis Mounting Floating Model
- 1 Double-pole changeover switch Bulgin S.98
- 1 On-off toggle switch Bulgin S.102
- 1 On-off toggle switch Bulgin S.80
- (Claude Lyons.)
- 1 5-way connector Wilburn
- 1 5-way battery cable, with twin 70/30 leads Harbros
- 2 5-pin plugs Bulgin P.3
- 2 Knobs Bulgin K.14
- 4 Ebonite shrouded terminals, A., E., pick-up (2) Belling-Lee "B"
- 2 Lengths screened sleeving Harbros
- 1 Metal chassis, complete with screws, nuts and washers Haynes Radio
- 6 Lengths Systoflex, 2 ozs. No. 20 tinned copper wire, etc.
- Valves:—2 Mullard VP4, or Ferranti VPT4, 1 Cossor DD/Pen., 1 Mazda PP5/400 or Marconi or Osram PX25.

**Power Unit**

- 1 Mains transformer, Primary: 200 to 250 volts, 50 cycles; secondaries: 450-0-450 volts, 120 mA., 4 volts 2.5 amp. centre-tapped; 4 volts 5/6 amp. With screened primary. Bryce AB573/5
- 1 L.F. smoothing choke, 26 henrys, 120 mA., 140 ohms, D.C. resistance. Savage "Massicore" RC27M
- 2 Fixed condensers, 4 mfd., 550 volts, D.C. working, in rectangular metal containers Dubilier L.C.G.
- 2 Valve holders, 5-pin Clix Chassis Mounting Standard Model
- 1 5-way connector Wilburn
- 1 Metal chassis, complete with screws, nuts and washers Haynes Radio
- 2 Lengths Systoflex, 1 oz. No. 20 tinned copper wire, etc.
- 1 Loud speaker, with 5,000 ohms field, and high impedance speech coil for PP5/400 valve Baker's S.P.D. Black Cone
- Valves:—1 Marconi or Osram MU11.

facilitating the mounting of components in their correct relative positions.

**High Standard of Quality**

The sensitivity and selectivity are adequate for most normal requirements, while the quality of reproduction reaches a very satisfying standard. The volume obtainable is ample for all domestic purposes.



# Tone Compensating Devices

## Units that Improve Record Reproduction

**T**HE fidelity of modern gramophone recording is now so good that by using a carefully corrected pick-up and an amplifier of straight line characteristics the reproduction can be brought exceedingly near to the original. Several weak links, however, still exist in the chain between the performers and the listeners. These are not all in the reproducing apparatus, and one by one they are being strengthened.



Bulgin scratch filter choke.

In the conversion from mechanical to electrical energy, and then back again to mechanical, in the form of sound waves, many inequalities appear, and it is with a view to smoothing out these that the technician has brought to his aid tone compensating devices.

The average gramophone pick-up is a fairly complicated electrical structure, but it may for simplicity be regarded as a generator in series with a resistance and an inductance. Therefore the simplest of all tone correctors would be a condenser, for at a certain frequency the inductance and the capacity will form a resonant cir-

cuit and result in a peak appearing on the response curve, but this is followed by a sharp cut off. Similarly a pronounced peak could be depressed by some other combination. One that would serve this purpose was described in our issue of October 27th last.

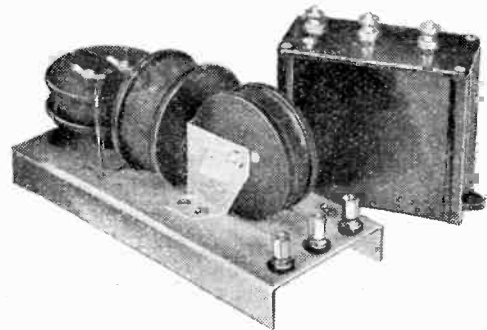

Wearite low pass filter and whistle filter.

A more common arrangement is to join a condenser and a resistance, or a choke, across the primary winding of the output transformer, and if the resistance is made variable the amount of correction is then brought under control.

There are several devices on the market, either designed for, or which could be made to serve the purpose of eliminating needle scratch. Any filter

giving a sharp cut off at a frequency just below that where record surface noises become troublesome can be utilised. One example is the Bulgin Scratch Filter Choke, and which is joined directly across the pick-up terminals. This gives a cut-off at about 4,000 c/s.

In the Wearite range are two Heterodyne Whistle Filters and one Low Pass Filter that would be applicable to this case. The whistle filters cut off at 3,500 c/s and 5,000 c/s respectively, while the Low Pass Filter is a somewhat more complicated arrangement, but gives a very sharp attenuation above 3,500 c/s.

Further examples are the Kinva "Steepslope" and "Sideband" splash

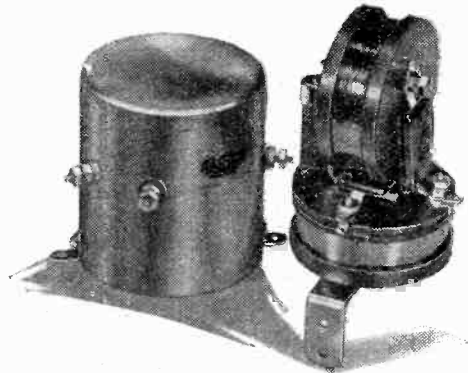

Kinva type "D"2 dual range filter and the A3 model.

filters, the A3 model in the former style cutting off at 3,500 c/s, while the "D" 2 "Sideband" splash filter gives the option of two end points, the one at 3,500 c/s and the other at 4,500 c/s.

The Goltone P.A. Tone Control has claims for inclusion in this class, although it was designed in the first case to moderate the high note response of a pentode.

The filters so far mentioned are all of the fixed or semi-fixed type designed to curtail the frequency response at some predetermined point on the musical scale, and they are best described as tone correctors. Another expression, often applied to a device which modifies the frequency response, is "tone control," but it would seem more appropriate to reserve this for those that change the form of the characteristic of the amplifier and which afford a control to the degree of compensation so effected.

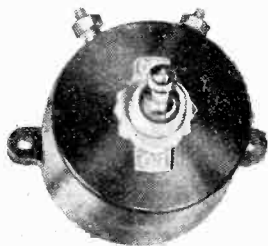

Goltone tone control giving option of two cut-off points.

Perhaps the best examples of this are the Multitone tone control transformers, for by the rotation of the knob of a potentiometer the amplifier's characteristic can be varied continuously from a good bass response without treble, to a good high note response without bass, whilst an intermediate position gives a

sensibly straight line curve. One of these models interposed between the pick-up and the set will afford all the tone control usually obtained by other means, but without making a single alteration to the set. The Toco model 1:4 ratio is best

Multitone tone control transformer.

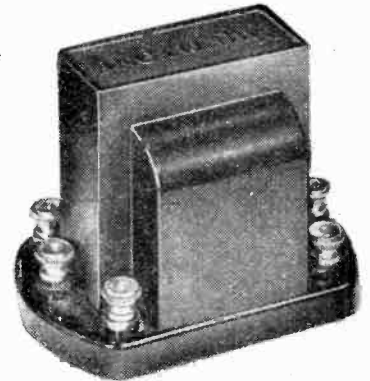

suited for this purpose. Tone control and the suppression of record surface noises is provided, also, by the Harlie Tone Selector and Scratch Filter, a very neat and compact unit.

The Gambrell Novotone needs no introduction, for it has been in existence now for a number of years. That it should have successfully withstood the test of time with little more than quite minor changes, and these, moreover, only to keep pace with the improvement in recording and in pick-ups, is indicative of the soundness of its design. Briefly, its function is to compensate for the deficiencies in recording and in the whole of the apparatus used for reproduction. By an arrangement of special transformers it gives greatly increased amplification at both ends of the frequency scale and at parts where normally the response would be below the mean level.

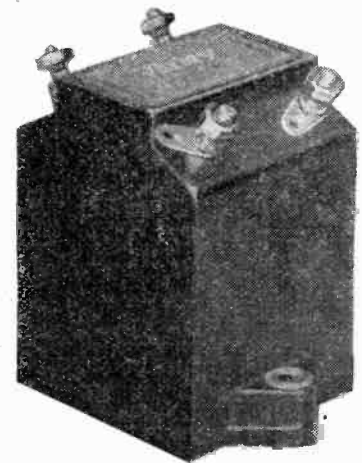

Varley compensating R.C.C. unit which has a rising characteristic.

Control of the upper register's amplification can be effected by fitting a 50-ohm variable resistance across two of the input terminals, while, if desired, the amplitude of the bass can be modified by fitting a condenser and a resistance across the output terminals.

# Detector Interaction

## Causes and Elimination of Certain Whistles in Superheterodynes

By G. J. REDFERN

ARTICLES have recently appeared in *The Wireless World* on the cause and origin of certain squeals and howls peculiar to the superheterodyne principle of reception, such as "second-channel" interference and sub-harmonic interference, etc., but, so far as the writer is aware, no mention has yet been made or suggestion offered as to the origin of undesirable responses occurring in the form of loud whistles when a superheterodyne receiver is tuned to frequencies equivalent to twice or higher multiples of the frequency of the intermediate-frequency stage. These whistles are noticed to be particularly bad on the long-wave band and would occur at approximately 220 kc/s when an I.F. of 110 kc/s is used, or at 250 kc/s on the tuning dial when 125 kc/s I.F. is used.

### A Whistle for Each Harmonic

Further whistles occur (in the case of the 110 kc/s intermediate frequency) at the following dial settings:—220, 550, 660, 770, 880, 990, 1,100, 1,210, 1,320, and 1,430 kc/s, which represent up to the 13th harmonic of the intermediate frequency.

It may be noticed that whistles do not occur unconditionally on all these settings unless stations radiating their carriers are within up to 5 or 6 kc/s in frequency either side of the above I.F. harmonics. Even then they will be present only in very sensitive receivers used under conditions giving a large signal input.

The writer carried out a number of experiments in the laboratory with a view to removing these troubles, and, happily, met with considerable success in being able to eliminate entirely all these whistles; at the same time the general noise level was also appreciably cut down.

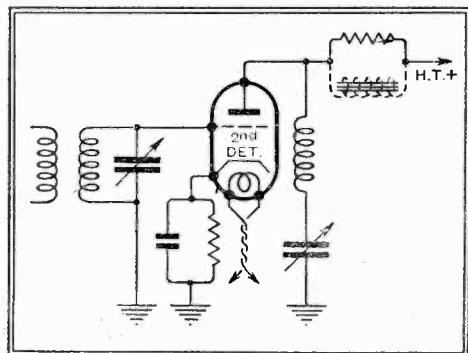

Fig. 1.—A tuned acceptor circuit connected in the anode circuit of a second detector.

It was proved that the sole cause of these whistles was a peculiar form of coupling and regeneration between the first and second detectors. This, at first sight, seems almost impossible, since the first detector is operating principally at high frequencies, while the second detector

works principally at intermediate and audio frequencies. It must be remembered, however, that the second detector, owing to its characteristics being non-linear, is capable of producing many harmonics of the intermediate frequency. Coupling can then take place between the H.F. circuits carrying the signal and any harmonic produced in the second detector. Obviously, then, an audio beat note will be produced between the oscillatory currents present in the second detector and H.F. circuits. The beat note heard will vary with the setting of the tuning dial, just as if the set were oscillating.

It was found that by offering a very low impedance path, which consisted of a suitable coil and small variable condenser in series, connected across the "high" point of the second detector and earth, and tuning the circuit thus formed to the same frequency as one of the harmonics, the heterodyne whistle was entirely eliminated. The acceptor circuit thus formed absorbed all the unwanted currents. This is shown in Fig. 1.

The interposition of a high-impedance H.F. choke between the "high" side of the second detector and the following audio coupling greatly assists the "harmonic rejector" in its action. This extra choke may with advantage be tuned to the same frequency as the rejector, and will, at the same time, prevent any I.F. currents of twice the I.F. from finding their way into the following audio couplings. Fig. 2 shows this. It may be found convenient to make the capacity of the variable condenser approximately 250 micro-microfarads and the coil of suitable inductance. The capacity of the condenser would then serve a dual purpose.

### Screening the Detector Stage

By arranging virtually complete screening between the H.F. stages and the second detector, whistles from the higher I.F. harmonics will be eliminated. The most convenient way to do this would be to assemble all the high H.F. potential leads and components associated with the second detector, and the valve itself, in one complete screening compartment. In view of the strength of the second harmonic (220 or 250 kc/s) it will be found

essential to include a suitable rejector circuit as mentioned.

Of perhaps greater importance than the whistles is the reduction of background noise which is found. The noise is due largely to coupling between adjacent numerical values of first detector and second detector harmonics, such as the second detector second harmonic and first detector first or third harmonic. Also the fifth or sixth harmonic of the first detector and fourth, fifth, sixth, or seventh harmonic of the second detector, etc. All these various combinations can give rise to a supersonic beat equivalent to the frequency of the I.F. stage and thus are passed along again and modulated by the I.F. carrier to the second detector, giving

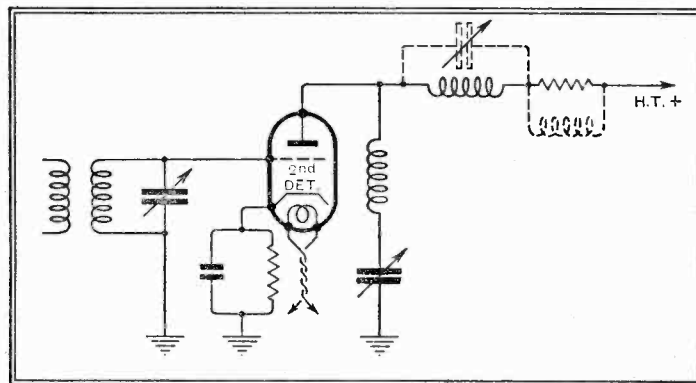

Fig. 2.—The addition of a second tuned circuit to the simple "harmonic rejector" shown in Fig. 1.

rise to hiss and to a noisy background generally.

It is possible that when these precautions are taken that certain limits as to the practicable values of intermediate frequencies will be removed, rendering it easier to choose a suitable value of I.F.

The writer has been able, with a harmonic rejector and an I.F. of 125 kc/s, to tune the radio circuit down as low as 930 kc/s, which is only 5 kc/s removed from the first and strongest harmonic, without any trouble whatsoever.

The arrangement as described does not in any way impair the normal sensitivity or selectivity of the receiver, but has the advantage of removing something that is not wanted and, it is hoped, will help to establish the superheterodyne still more firmly as the best all-round receiver.

### Valve Data Booklet

IT is regretted that an error occurred in *The Wireless World Valve Data Booklet* with regard to the calculation of the power rating of bias resistances. The last sentence of the third paragraph of the section headed "Output Pentodes" on page 4 should read: "The watts rating of the resistances can be found by multiplying the resistance by the square of the sum of the anode and screen currents and dividing the result by 1,000,000."



# Bush Superheterodyne TYPE S.A.C.4

A Quality Product at a Moderate Price

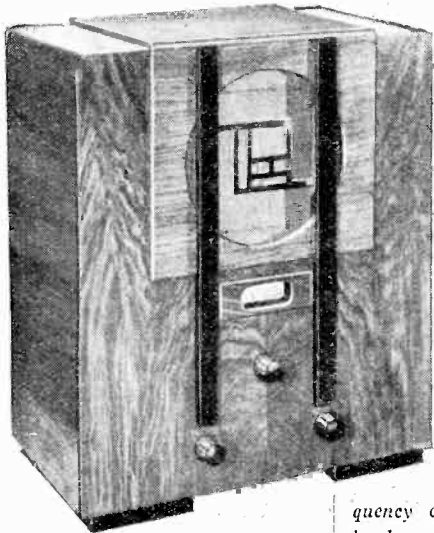

**A**LTHOUGH the price of this set is only 13 guineas, a close examination does not give the impression that price has had any influence on the circuit specification or that cheap labour has been employed in the construction and assembly.

Basically the circuit is the familiar four-valve superheterodyne with a detector-oscillator, single I.F. stage, second detector, and power output valve, but there are numerous detail refinements which contribute to the better performance of the receiver. In the band pass input circuit, for instance, the inductive coupling is automatically adjusted for medium and long waves, and reverse coupling is arranged between the tuned secondary and the aerial coupling coil to neutralise second channel interference.

The detector-oscillator valve is of the screen-grid pentode type and is totally enclosed in a separate screening can to eliminate re-radiation and stray couplings. The I.F. valve is a variable- $\mu$  H.F. pentode and volume is controlled by varying the grid bias resistance, a portion of which is shunted across the aerial circuit. The second detector is of the anode bend type and the bias is automatically reduced by contacts in association with the pick-up plug and jack. Resistance coupling is used between the detector and pentode output valve and a resistance-capacity filter is included to by-pass stray I.F. currents. A Westinghouse metal rectifier provides the supply to the anode circuits, which are very

completely decoupled. The H.T. current is smoothed by the L.S. field which, in conjunction with a hum-bucking coil in the loud speaker unit, gives a negligible hum level.

From the point of view of neat design and clean workmanship the chassis is one of the

ground hiss is rather noticeable at times. The well-graded tone control, however, enables a satisfactory reduction in background noise to be effected without serious detriment to the quality. While the tonal balance is excellent, there is a slight tendency to harmonic distortion at low and high volume levels, but at an average level suitable for the normal living room no criticism is possible on this score.

The range is sufficient to give all worthwhile programmes and is as much as can reasonably be expected with stability from four stages. The selectivity, on the other hand, was unexpectedly good, and but for side-band splash, adjacent channel separa-

**FEATURES. Type.**—Table model superhet. for A.C. mains incorporating moving-coil loud speaker. **Circuit.**—Band-pass input filter—H.F. pentode frequency changer—variable- $\mu$  H.F. pentode I.F. valve—anode bend second detector—power pentode output. **Controls.**—(1) Tuning with illuminated and calibrated dial. (2) Volume and on-off switch. (3) Wave-range. (4) Tone control. **Price.**—13 guineas. **Makers.**—Bush Radio Ltd., Woodger Road, Shepherd's Bush, London, W.12.

best we have so far examined. The band-pass and oscillator coils are mounted underneath the chassis on a transverse partition which also carries the wave-range switch. The latter consists of a silver-steel rod carried in substantial brass bushes and has flats milled at intervals which act as cams for the spring switch blades. The design is simple but effective and should give reliable service throughout the life of the set. Space does not permit a detailed enumeration of the little details which indicated the conscientious nature of the construction, but it is safe to say that such quality of material and workmanship is seldom found in receivers of comparable price.

The moving-coil loud speaker is one of the new manufacturer's type B.T.H. units and combines a very widely distributed bass response with good transient attack. The high frequency response is such that back-

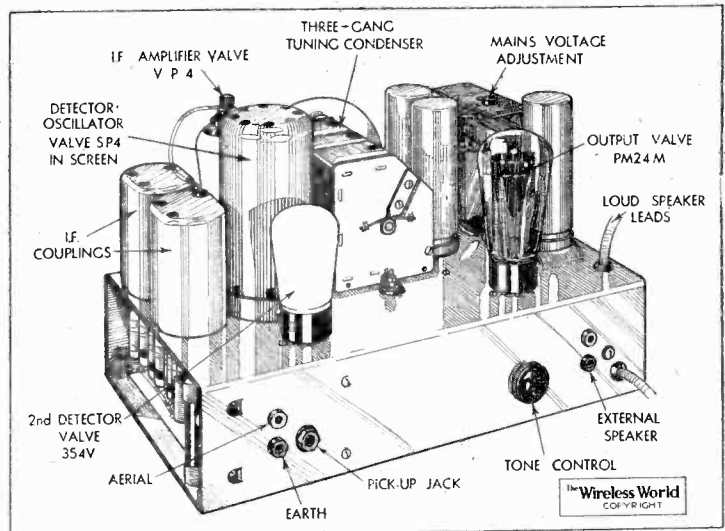

The workmanship and finish of the chassis are of an unusually high standard.

tion would have been possible on both Brookmans Park transmitters in Central London. The performance on long waves is in keeping with that on medium waves and sets a very high standard for a four-valve receiver.

The cabinet conforms to modern standards of design, and is solidly constructed and well finished—and by that we do not mean superficial polish, but conscientious workmanship in out-of-the-way corners, which is characteristic of the set as a whole.

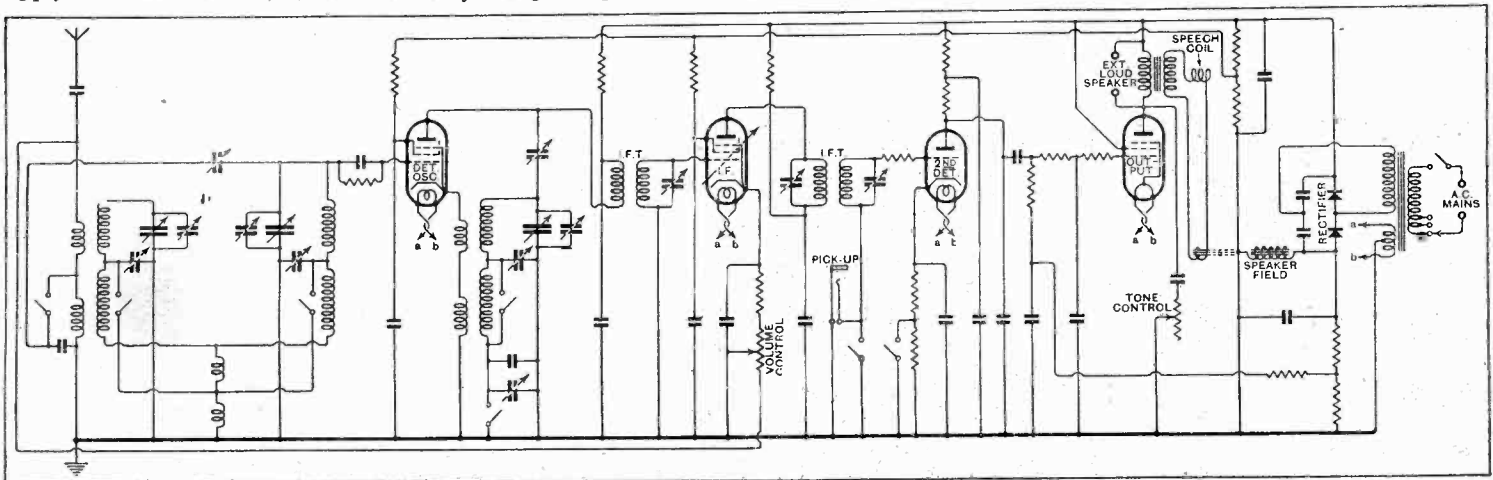

Complete circuit diagram. The input filter is designed to suppress second channel whistles.

## Letters to the Editor:—

# Stereophonic Broadcasting

## Plea for Experimental Transmissions : Duplicating Equipment

The Editor does not hold himself responsible for the opinions of his correspondents

### Double Channel Broadcasting

From Professor H. Hartridge, F.R.S.

I ENTIRELY agree with the opinions expressed in recent letters to your journal that the "twin microphone" method necessitates the use of headphones, the use of loud speakers being difficult or impossible. There is, fortunately, another method of double channel transmission which may be called the "twin studio" method, and this, in contradistinction to the twin microphone method, necessitates the use of loud speakers, the use of headphones being difficult or impossible. So far as I know, this method has not been previously described. Its essential requirements are two sound-proof studios, each of which contains a microphone. One microphone is connected to one transmitter, the other to the second transmitter. The listener uses two receivers, each of which is connected to its loud speaker. Now the National Physical Laboratory have shown recently that two sheets of plate glass separated by an air gap of suitable thickness forms a partition which is almost completely sound-proof. Such a partition is used to separate the two studios. Suppose a discussion to be taking place between two people; one speaker is placed in one studio, the other in the other. They are visible to one another but cannot hear one another until they have put on headphones. Thus, when A speaks, B hears him through the headphones, which are connected to A's microphone, and vice versa. Each speaker is separately broadcast and received by the listener, who hears A speaking out of one loud speaker and B out of the other.

### Complicated Examples

In the case of a vocalist or any single instrument accompanied by a piano or orchestra, the solo part is performed in one studio and the accompaniment in the other. The listener hears one of his loud speakers reproducing the solo part, and the other reproducing the accompaniment. A small point of detail arises here: the soloist is caused to hear the accompaniment *via* his headphones. Similarly, the accompanying pianist or orchestra is caused to hear the soloist through headphones. But it is clear that each performer must also be able to hear his own instrument (for otherwise he might, for example, play out of tune), and this could be arranged by leakage past the headphones. A felt pad of suitable thickness between the headphone and the ear should enable the necessary leakage of sound to take place. Since the performers both hear and see one another they should be able to keep in time. So far as can be foreseen they can fail only in one way, namely, by not keeping in correct relative intensities. Thus, either soloist or accompaniment may be too loud in respect to the other. These relative intensities may be corrected by the announcer who is in charge of the broadcast, or some other equivalent person. He is provided with two loud speakers each fed by one channel, just as if he were an ordinary listener; by means of a differential volume control he keeps the

relative intensities of the performers at a suitable value.

When a band or orchestra is being broadcast many arrangements are possible; thus, in the case of a band the wind instruments could be played in one studio, and the drums and triangle in the other. With an orchestra, the string instruments could be in one studio and the wind instruments in the other. With either of these plans a more elaborate arrangement could be used by the listener if he wished to employ it. Instead of using two loud speakers, each of which covers the whole musical scale, four loud speakers might be employed, two treble prominent (e.g., electrostatic) and two bass prominent (e.g., large moving-coil). One treble loud speaker and one bass loud speaker is connected to one set, the other pair to the other. The listener might arrange these loud speakers as follows: Treble strings reproduced by the loud speaker on the extreme right, bass strings by loud speaker on middle right, bass winds and drums by loud speaker on middle left, and treble winds and triangle by loud speaker on extreme left. By altering the positions of the loud speakers other arrangements could be tried. The B.B.C. might from week to week publish in *The Listener* the actual arrangement of the orchestras and bands which are to be broadcast, so that listeners might imitate the positions of the different parts of the orchestra or bands as closely as their facilities would allow.

### Glass Partitions

One more point in connection with bands or orchestra: it would be possible for the conductor to be in one studio and to be seen through the glass partition by the performers in the other studios. But a better arrangement would be to place the conductor in a small room (or passage) separating the two studios so as to be visible to the performers in both through sound-proof double glass partitions. He would be enabled to hear the sound produced in the two studios by means of loud speakers which are arranged exactly like those used by listeners. In this way he would be able to control the different players so as to obtain the best results for listeners. It would probably be quite unnecessary for the performers to use headphones in order to hear what the other half of their band or orchestra are doing.

In conclusion, I would like to emphasise the value of experimental double channel transmissions and to express a hope that they will begin soon. H. HARTRIDGE.

London.

### Necessity for Duplicating Equipment

YOUR correspondents on the above subject raise a question as to whether binaural transmission and reproduction can be effective when loud speakers are used in place of headphones.

Correspondence, which should be as brief as possible, should be addressed to the Editor, "The Wireless World," Dorset House, Stamford Street, S.E.1, and must be accompanied by the writer's name and address

My own opinion is that the directional effect cannot be perfectly obtained by means of two loud speakers operating in a reverberant reproducing room such as that ordinarily used, but, on the other hand, the use of two such channels instead of one may quite possibly produce a great improvement in the general character of the result.

Everybody, for example, who has listened to piano reproduction is acquainted with the peculiar quality occasionally obtained on certain individual notes. In a large number of cases this has proved to be due to acoustic interference in the transmitting studio, as a slight movement of the microphone will transfer the trouble from one note to another.

The fact that no such effect is obtained by a listener in the studio indicates very strongly that if two microphones were located in the studio and *separately* extended through *separate* channels to the two ears of the listener, no trouble would be experienced. The presumption in this case is that the interference effects on the listener's two ears average each other out.

It is an open question, and one which can only be settled by experiment whether such an averaging process would be obtainable if the two channels terminated in two loud speakers contained in a single reverberant room. Certainly there would no longer be a state of affairs, such as that obtaining at present, where the suppression of a single frequency by acoustical interference at the particular point occupied by the transmitting microphone necessarily results in the suppression of this frequency in any reproducing room whatever.

The use of two telephones and two transmission channels is admittedly the only way in which real acoustic fidelity can be achieved, but, granted that we give up the attempt at scientific reconstruction of the original sound, there seems to be every prospect of obtaining a better result with two channels and two loud speakers than with present-day apparatus, and there is no reason, *a priori*, why such a result should not be as satisfying as the performance itself, though necessarily different from it.

London, W.C.2. P. W. WILLANS.

### The Radio Industry

THE firm of Ward & Goldstone, Ltd., has just secured contracts for the supply of their air-spaced screened down-lead cable from both the Home and Dominion Governments. It is understood that this low-capacity cable is being successfully employed for short-wave transmission and reception.

"Practical Hints on the Patenting and Development of Inventions" is the self-explanatory title of a useful and well-written 32-page booklet just received from the Imperial Patent Service, First Avenue House, High Holborn, London. W.C.1.

The Marconiphone Company announces the introduction of a new battery-operated super-heterodyne portable receiver (Model 269), with delayed A.V.C. and the latest type of Q.P.P. output stage.



# The Wireless World

THE  
PRACTICAL RADIO  
JOURNAL  
23<sup>rd</sup> Year of Publication

No. 743.

FRIDAY, NOVEMBER 24TH, 1933.

VOL. XXXIII. No. 21.

Proprietors: ILIFFE & SONS LTD.

Editor:  
HUGH S. POCOCK.

Editorial,  
Advertising and Publishing Offices:  
DORSET HOUSE, STAMFORD STREET,  
LONDON, S.E.1.

Telephone: Hop 3333 (50 lines).  
Telegrams: "Ethaworld, Watloo, London."

COVENTRY: Hertford Street.  
Telegrams: "Cyclist, Coventry." Telephone: 2520 Coventry.

BIRMINGHAM:  
Guildhall Buildings, Navigation Street, 2.  
Telegrams: "Autopress, Birmingham." Telephone: 2970 Midland (3 lines).

MANCHESTER: 260, Deansgate, 3.  
Telegrams: "Iliffe, Manchester." Telephone: Blackfriars 4412 (4 lines).

GLASGOW: 26B, Renfield Street, C.2.  
Telegrams: "Iliffe, Glasgow." Telephone: Central 4857.

PUBLISHED WEEKLY. ENTERED AS SECOND  
CLASS MATTER AT NEW YORK, N.Y.

Subscription Rates:  
Home, £1 1s. 8d.; Canada, £1 1s. 8d.; other  
countries abroad, £1 3s. 10d. per annum.

*As many of the circuits and apparatus described in these  
pages are covered by patents, readers are advised, before  
making use of them, to satisfy themselves that they would  
not be infringing patents.*

## CONTENTS

	Page
Editorial Comment .. ..	401
The Wireless World A.V.C. Straight Four .. ..	402
Battery Economy with the Westector .. ..	405
Ultra Short-wave Superheterodynes	406
News of the Week .. ..	408
<b>FOREIGN PROGRAMME</b>	
SUPPLEMENT, pp. 1—XXIV	
Broadcast Brevities .. ..	409
New Apparatus Reviewed .. ..	410
Television Explained .. ..	411
Letters to the Editor .. ..	413
The Faraday All-wave Super- heterodyne .. ..	415
Readers' Problems .. ..	416

## EDITORIAL COMMENT

### Calibrating the Receiver

*A Great Opportunity in  
January*

**T**HE nights of January 14th and 15th next should be of unique interest to readers of *The Wireless World*. As we were able to reveal last week, the International Broadcasting Union has wisely decided that the great transfer of wavelengths under the Lucerne Plan shall be conducted as far as possible in an orderly fashion under the direct supervision of the Union's own checking station at Brussels.

The magnitude of the operation is without parallel in the history of wireless. Whereas, with the inception of the Prague Plan six years ago, there were 173 stations to be accounted for, now there are no fewer than 230—many of higher power—and M. Brailard, the technical secretary of the Union, will add fresh laurels to his already established reputation as "ether policeman" if the plan of operations is successful.

### *Orderly Progression*

The attractiveness of the plan, apart from the probability that it will avoid the comparative chaos which attended the introduction of the Geneva and Prague wavelength schemes, lies in the possibility that every European station may, at the start, at any rate, be working on a known wavelength, guaranteed accurate by the Brussels wavemeter. Listeners will thus have an unprecedented opportunity to calibrate their own receivers. On the actual night of the transfer, beginning at Zero Hour (11 p.m. G.M.T.) certain high power stations, easily receivable in this country, will be transmitting announcements as and when each station is

calibrated at the control point. Most British listeners will probably tune-in Radio-Paris, which will be recording the progress of the change-over at the broadcasting stations in Belgium, Spain, France, Great Britain, Ireland, Iceland, Luxembourg, Morocco, Holland, Portugal and Switzerland. It will then be possible to "nail down" these transmitters one by one on the tuning dial of the receiver in reasonable confidence that the wavelengths are actually as stated.

### *Long-wave Prospects*

No doubt some listeners will seek an opportunity to follow the wave changes as they are being made in Central and Eastern Europe, but the purpose of calibration will be served if some twenty or more nearer stations can be accurately observed.

Minor wavelength changes are bound to follow as and when the Lucerne Plan is put to practical test, but the point of essential importance is that every listener who has carefully followed the checking process will have a receiver calibrated throughout the tuning scale. To achieve such an end it will be worth while on January 14th and 15th, misquoting Milton, to "shun delights and live laborious nights."

Unhappily these bright prospects are confined to the medium waveband. Of the twelve countries using long waves, five are non-signatories to the Lucerne Plan, and it is difficult at the moment to see how any arrangement of the long waves can be satisfactory until all long-wave users can be brought to understand that the old roving days are over so far as European broadcasting is concerned.

Perhaps the delinquents will bow to the inevitable, as has just been done by the recalcitrants on the medium waves, by adopting the Lucerne Plan "without any obligation."

# The Wireless World

## A.V.C. STRAIGHT FOUR

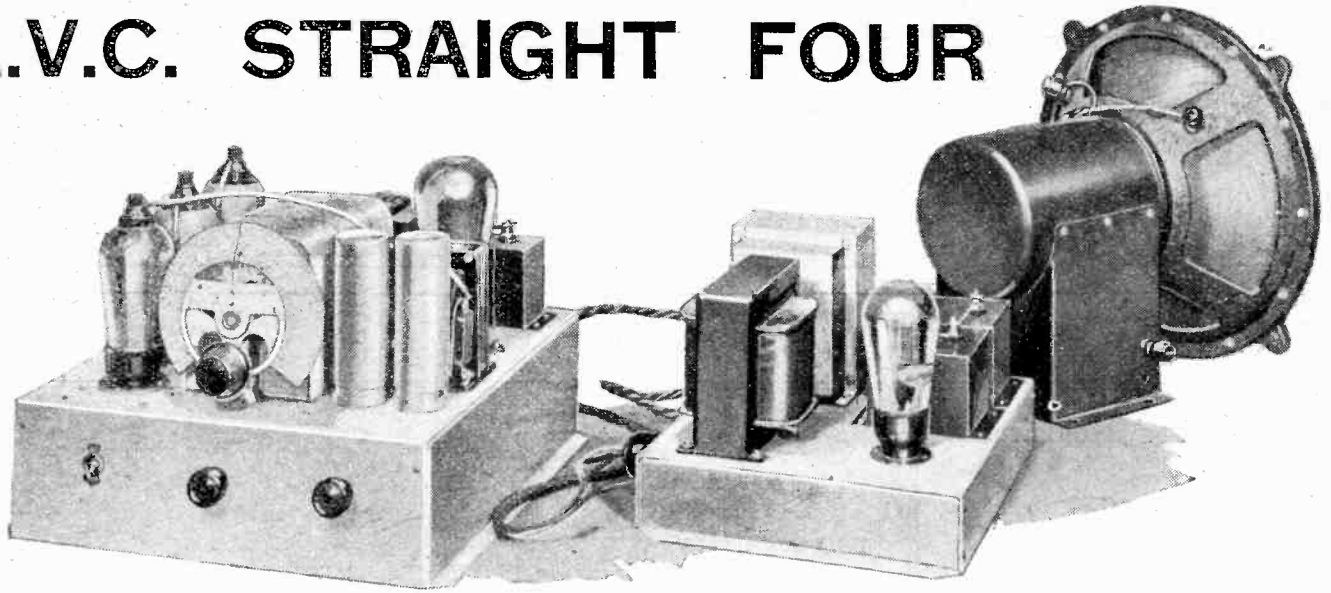

### A Highly Selective A.C. Receiver Including Iron-Cored Coils

*THE introduction of iron-cored tuning coils has permitted such a great increase in the selectivity of the straight set that it can now approach that of the superheterodyne, and once more take its place as a satisfactory receiver for distant reception. The A.V.C. Straight Four includes four such circuits, and automatic volume control is fitted to reduce the effects of fading.*

**A**LTHOUGH the superheterodyne has largely ousted the straight set where high selectivity and sensitivity are required, this is in great measure due to a trend which set in before the advent of compact high-efficiency tuning coils. This does not mean, of course, that the trend is in a wrong direction, for the characteristics of the superheterodyne are such that its popularity would have been inevitable. Had iron-core coils been developed earlier, however, it is safe to say that the straight set would not have been displaced to such a large degree.

One of the outstanding advantages of the straight set is its freedom from second channel interference, and, in the eyes of many, this is sufficient to compensate for the somewhat lower adjacent channel selectivity as compared with the superheterodyne. Furthermore, the ganging adjustments are simpler.

However efficient a coil may be, it becomes of no avail if it be connected in a circuit incorrectly. The connection of any components to a tuned circuit inevitably lowers its efficiency to some degree, but such additional components are essential if any use is to be made of the circuit.

The problem of design, therefore, resolves itself into finding that method of connection which introduces a minimum of loss while still retaining efficiency.

A glance at the circuit diagram of Fig. 1 shows that, in the case of the aerial tuned circuit, the first valve is connected across the whole of the coil, for the input impedance of a screen-grid H.F. amplifier is quite high and it throws little damping on the tuned circuit. The aerial, however, is connected to a tapping on the coil which is so placed that an efficient coupling is obtained with a minimum of damping. In order that the ganging may

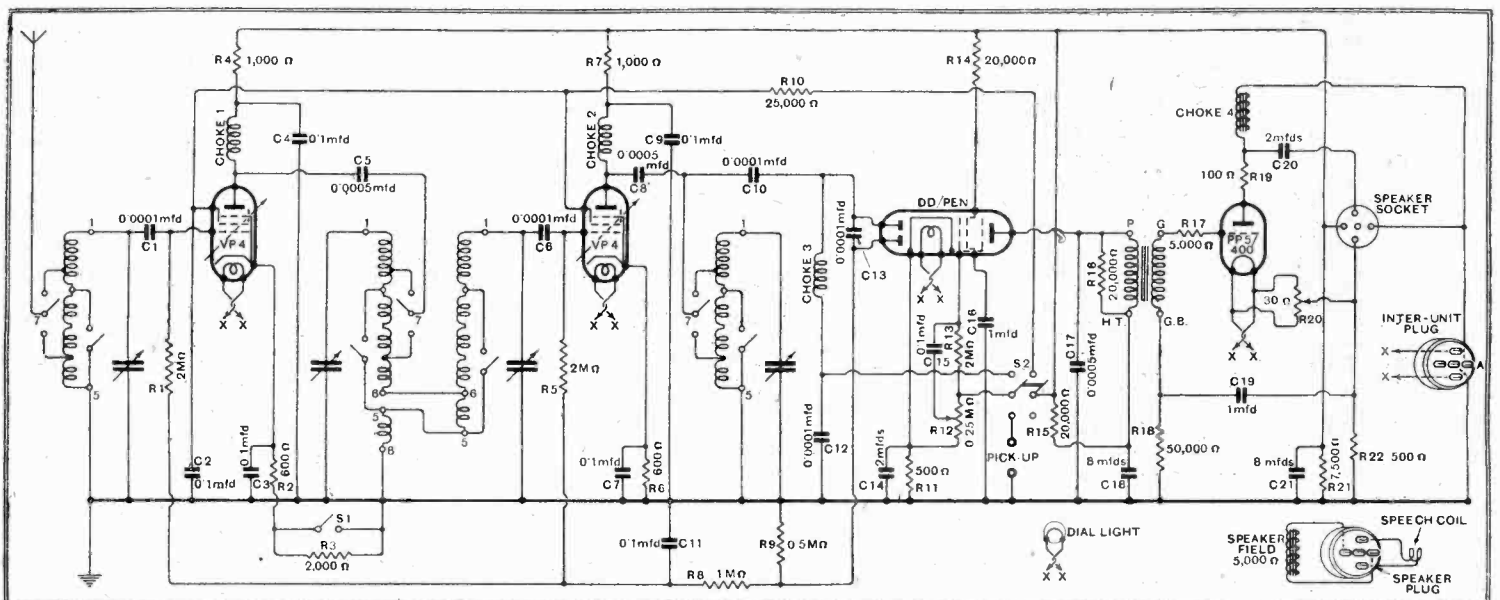

Fig. 1.—The circuit diagram of the receiver unit. It will be noted that the band-pass filter is fitted between the two H.F. stages for which variable-mu H.F. pentodes are employed. The detector is a duo-diode-pentode.







**The A.V.C. Straight Four—**

the initial smoothing in conjunction with the 4  $\mu$ F. condenser C22. The potential available across this condenser is about 430 volts and is applied directly to the output valve. A certain drop in voltage occurs in the output choke No. 4 (Fig. 1) so that the true anode voltage on the output valve is slightly below its maximum rating of 400 volts.

Additional smoothing is required for the H.T. supply to the early valves, and this is obtainable from the speaker field in conjunction with the 8  $\mu$ F. electrolytic condenser C21. The field has a resistance of 5,000 ohms, and the current through it is slightly under 50 milliamperes, so that the voltage drop across it is about 240 volts, and a supply of 190 volts is available for the nominally 200 volts line.

The anodes of the H.F. valves are fed from this through 1,000 ohms decoupling resistances R4 and R7, with decoupling condensers C4 and C9 joined to earth. The screen grids, however, are not fed from a potentiometer in the usual way, but merely through a single dropping resistance. This is made possible by the use of H.F. pentodes for the H.F. stages, since the screen current in these valves is much more constant than usual. A further point in favour of this method of feeding the screens lies in the increased input handling capacity of the valves at high A.V.C. bias voltages, although this is to some extent offset by the necessity for using a higher bias for a given reduction in signal strength. These effects, of course, are brought about by the fact that the screen voltage rises as the bias is increased. It should be noted that one pole of the radio-gramophone switch is so connected that on gramophone it open-circuits the screen feed, thus effectively preventing any break-through of radio signals when records are being reproduced.

**The Mains Equipment**

The screen of the duo-diode-pentode is fed from the 200 volts line through a 20,000 ohms resistance R14, with a 1  $\mu$ F. decoupling condenser C16. Minimum bias on the H.F. stages is provided by the drop of voltage along the 600 ohms resistances R2 and R6, which are shunted by 0.1  $\mu$ F. condensers C3 and C7. In the case of the first H.F. stage it will be noted that the cathode circuit includes also a 2,000 ohms resistance R3 which can be short-circuited by the switch S1. The purpose of this is to avoid any possibility of distortion due to overloading when listening to the local station. For reception of a powerful station the switch can be opened and the initial sensitivity

of the set reduced, thus lessening the strain upon the A.V.C. system.

It will have been observed that the mains transformer has only a single winding for the heater supply to all the valves, apart from the mains rectifier. Hitherto, it has been necessary to employ a separate winding for a directly heated output valve, for its bias voltage otherwise appears as

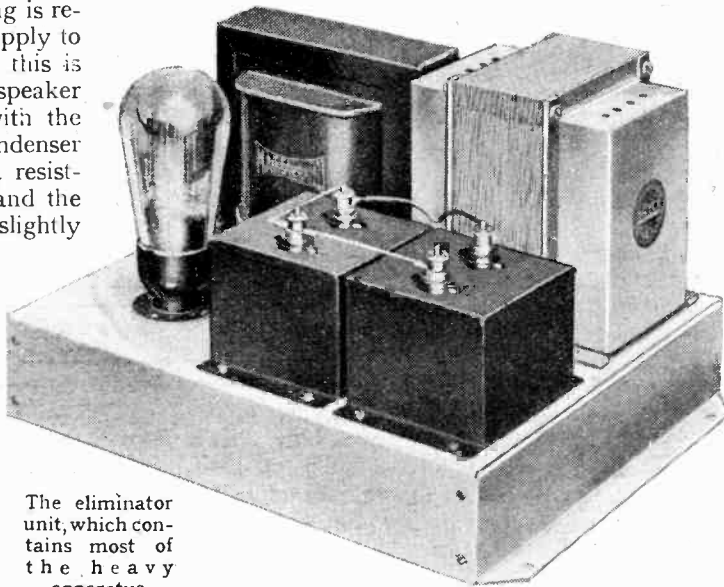

The eliminator unit, which contains most of the heavy apparatus.

a potential difference between the heaters and cathodes of the other valves. Recent progress in valve development, however, has made this unimportant, and it is now possible safely to adopt a single transformer winding for all valves.

The assembly of the components, wiring up, and the operation of the receiver will be dealt with in next week's issue.

**THE LIST OF PARTS.****Receiver Unit**

- |                                                                                                                                         |                                        |
|-----------------------------------------------------------------------------------------------------------------------------------------|----------------------------------------|
| 1 4-gang condenser                                                                                                                      | Polar "Star Minor"                     |
| 1 Dial for above                                                                                                                        | Polar "Full-Vision" Semicircular Drive |
| 1 Set of 4 Ferrocort coils on chassis, consisting of F.10, F.11, F.12 and F.13                                                          | Colvern                                |
| 3 Screened H.F. chokes, Ch1, Ch2, Ch3                                                                                                   | Bulgin H.F.9                           |
| 2 Electrolytic condensers, 8 mfd., 450 volts peak working, C18, C21                                                                     | Dubilier (Peak, T.C.C.)                |
| 1 Fixed condenser, 2 mfd., 550 volts, D.C. working, in rectangular metal container, C20                                                 | Dubilier L.C.G.                        |
| 1 Fixed condenser, non-inductive, 2 mfd., 250 volts, D.C. working, in cylindrical aluminium container                                   | Dubilier 9200                          |
| 2 Fixed condensers, non-inductive, 1 mfd., 250 volts, D.C. working, in cylindrical aluminium containers, C16, C19                       | Dubilier 9200                          |
| 7 Fixed condensers, non-inductive, 0.1 mfd., 250 volts, D.C. working, in cylindrical aluminium containers, C2, C3, C4, C7, C9, C11, C15 | Dubilier 9200                          |
| 5 Fixed condensers, 0.0001 mfd., C1, C6, C10, C12, C13                                                                                  | Dubilier 665                           |
| 2 Fixed condensers, 0.0005 mfd., C5, C8                                                                                                 | Dubilier 665                           |
| 1 Fixed condenser, 0.0005 mfd., C17                                                                                                     | Dubilier 670                           |
| 1 Resistor, 30 ohms, R20                                                                                                                | Claude Lyons "Humdinger"               |
| 1 Wire-wound resistance, 7,500 ohms, 20 watts, R21                                                                                      | Bu'gin PR.10                           |
| 1 Resistance, 100 ohms, 1 watt, R19                                                                                                     | Erie                                   |
| 1 Resistance, 500 ohms, 1 watt, R11                                                                                                     | Erie                                   |
| 1 Resistance, 500 ohms, 3 watts, R22                                                                                                    | Erie                                   |
| 2 Resistances, 600 ohms, 1 watt, R2, R6                                                                                                 | Erie                                   |
| 2 Resistances, 1,000 ohms, 1 watt, R4, R7                                                                                               | Erie                                   |
| 1 Resistance, 2,000 ohms, 1 watt, R3                                                                                                    | Erie                                   |
| 1 Resistance, 5,000 ohms, 1 watt, R17                                                                                                   | Erie                                   |
| 3 Resistances, 20,000 ohms, 1 watt, R14, R15, R16                                                                                       | Erie                                   |
| 1 Resistance, 25,000 ohms, 1 watt, R10                                                                                                  | Erie                                   |
| 1 Resistance, 50,000 ohms, 1 watt, R18                                                                                                  | Erie                                   |
| 1 Resistance, 500,000 ohms, 1 watt, R9                                                                                                  | Erie                                   |
| 1 Resistance, 1 megohm, R8                                                                                                              | Erie                                   |
| 3 Resistances, 2 megohms, R1, R5, R13                                                                                                   | Erie                                   |
| (Dubilier, Graham Farish, Claude Lyons, Seradex.)                                                                                       |                                        |
| 1 Tapered volume control, 250,000 ohms, R12                                                                                             | Magnum (Claude Lyons, Watmel.)         |
| 1 L.F. transformer, 1 : 3½                                                                                                              | Ferranti AF5                           |
| 1 L.F. choke, 20 henrys, 60 mA., Ch4                                                                                                    | R.I. DY51                              |
| 4 Valve holders, 5-pin                                                                                                                  | Clix Chassis Mounting Standard Model   |

- |                                                                                                      |                                      |
|------------------------------------------------------------------------------------------------------|--------------------------------------|
| 1 Valve holder, 7-pin                                                                                | Clix Chassis Mounting Floating Model |
| 1 Double-pole changeover switch, S2                                                                  | Bulgin S.98                          |
| 1 On-off toggle switch, S1                                                                           | Bulgin S.102                         |
| (Claude Lyons.)                                                                                      |                                      |
| 1 5-way connector                                                                                    | Wilburn                              |
| 1 5-way battery cable, with twin 70/36 leads                                                         | Harbros                              |
| 2 5-pin plugs                                                                                        | Bulgin P.3                           |
| 2 Knobs                                                                                              | Bulgin K.14                          |
| 4 Ebonite shrouded terminals, A., E., pick-up (2)                                                    | Belling-Lee "B"                      |
| 2 Lengths screened sleeving                                                                          | Harbros                              |
| 1 Metal chassis, complete with screws, nuts and washers                                              | Haynes Radio                         |
| 6 Lengths Systoflex, 2 ozs. No. 20 tinned copper wire, etc.                                          |                                      |
| Valves:—2 Mullard VF4, or Ferranti VPT4, 1 Cossor DD/Pen., 1 Mazda PP5/400 or Marconi or Osram PX25. |                                      |

**Power Unit**

- |                                                                                                                                                                            |                                      |
|----------------------------------------------------------------------------------------------------------------------------------------------------------------------------|--------------------------------------|
| 1 Mains transformer, Primary: 200 to 250 volts, 50 cycles; secondaries: 450-0-450 volts, 120 mA., 4 volts 2.5 amps. centre-tapped; 4 volts 5/6 amp. With screened primary. | Bryce AB573/c                        |
| 1 L.F. smoothing choke, 26 henrys, 120 mA., 140 ohms, D.C. resistance, Ch5                                                                                                 | Savage "Massicore" RC27M             |
| 2 Fixed condensers, 4 mfd., 550 volts, D.C. working, in rectangular metal containers, C22, C23                                                                             | Dubilier L.C.G.                      |
| 2 Valve holders, 5-pin                                                                                                                                                     | Clix Chassis Mounting Standard Model |
| 1 5-way connector                                                                                                                                                          | Wilburn                              |
| 1 Metal chassis, complete with screws, nuts and washers                                                                                                                    | Haynes Radio                         |
| 2 Lengths Systoflex, 1 oz. No. 20 tinned copper wire, etc.                                                                                                                 |                                      |
| 1 Loud speaker, with 5,000 ohms field, and high impedance speech coil for PP5/400 valve                                                                                    | Baker's S.P.D. Black Cone            |
| Valves:—1 Marconi or Osram MU14.                                                                                                                                           |                                      |

**THE RADIO INDUSTRY**

AS befits members of a new industry, Partidge, Wilson & Co. (makers of Davenet apparatus) apparently hold progressive views on the employers' obligations towards employees. Their workpeople have just been given an all-round increase of 5 per cent. in wages. This is the second general increase during the year, and, in addition, a successful profit-sharing scheme is in operation.

The production of McMichael receivers for the month of October constituted a record for the firm. To celebrate the event, Mr. Leslie McMichael, a well-known figure both in amateur and trade circles, himself engraved the serial number plate for the last set to pass out of the test-room on October 31st.

The Edison Swan Electric Co., Ltd., are to market electrically operated Bulle clocks, both in mains- and battery-driven models.

The Sunbeam Electric Co. is shortly to occupy a new and larger factory in Park Royal Road, London, N.W.10.

The latest publication issued by Claude Lyons, Ltd., of 76, Oldhall Street, Liverpool, is justly entitled "A Helping Hand to Set Constructors." In addition to full technical descriptions of the many components and accessories produced by this firm, it includes many pages of circuit diagrams and technical notes. Readers may obtain copies by sending 3d. in stamps.

New Mullard valves.—Indirectly heated power rectifiers, types IW2 and IW3, giving rectified outputs of 60 milliamps at, respectively, 250 volts and 350 volts. As compared with the ordinary directly heated rectifier, the outstanding advantage of this new type is that an initial voltage rise, with consequent risk of damage to condensers, is avoided.

"This Year of Radio" is the title of an unusual and highly informative catalogue issued by Alfred Imhof, Ltd., 112-116, New Oxford Street, London, W.C.1, the well-known gramophone and radio dealers. All popular sets, radio-gramophones, and accessories are described at length; there are several "magazine" articles, and space is devoted to the "service" policy of the firm.



# Battery Economy with the "Westector"

## Automatic Bias Adjustment in the Output Stage

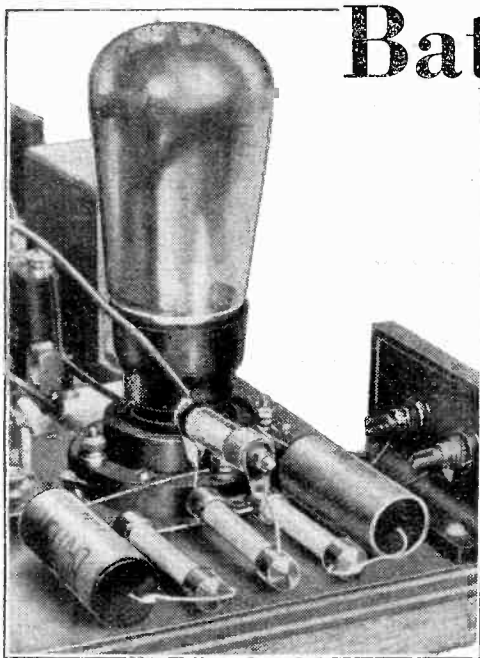

*THE majority of this season's battery receivers are fitted with Class "B" or Q.P.P. output stages which have superseded the single output valve with normal bias. The conversion of existing sets for battery economy is, however, a comparatively simple and inexpensive process if use is made of the latest metal oxide rectifiers.*

The principle of operation will be best understood by reference to Fig. 1, which shows a pentode output valve preceded by resistance-capacity coupling and feeding a moving-coil loud speaker. It will be found that pentodes give the best results in circuits of this type, as they show a better range of control for a given quiescent current. Transformer coupling could equally well be employed, but is not absolutely necessary as it is in the case of Class "B" output.

result in bottom bend rectification due to insufficient reduction of the standing bias, while too low a value will cause the valve to run to grid current. A certain amount of distortion is bound to occur in any type of quiescent output stage, but by judicious compromise in the choice of component values the harmonic distortion can be kept low over a considerable range of output power.

**A**LTHOUGH the majority of economical output stages employ two valves in some form of push-pull arrangement, it is quite possible to achieve comparable results with a single output valve. A valve biased to the middle of the straight portion of its characteristic is always consuming H.T. current at the rate required for its maximum power output. During the greater part of the time that the set is in operation a high bias and consequently a much lower average current can be tolerated without introducing appreciable distortion.

The essence of the scheme lies in tapping off a small fraction of the L.F. output, rectifying it and applying the resultant voltage to bias the output valve according to the power which it is called upon to handle. The Philips 832B receiver employs such an arrangement, a leaky grid triode rectifier being used to regulate the control bias in accordance with the input voltage.

### How the Bias is Derived

The grid bias battery should be capable of supplying approximately twice the normal bias voltage required by the valve. It is connected to the lower end of a potential divider ( $R_1, R_2$ ) which is connected to the anode through the blocking condenser  $C_1$  and by-passes a small fraction of the fluctuating output current. The effect of connecting the "Westector" across  $R_2$  is to short-circuit  $R_2$  for currents flowing upwards in the potentiometer, but to give it practically its full value for establishing a difference of potential from currents flowing downwards. The net result is the establishment of a voltage in opposition to the bias and of a strength depending on the signal. The resultant bias is led off to the grid circuit through the resistance-capacity filter  $R_3, C_2$ , the time constant of which is adjusted to give rapid response to a change of signal strength, but at the same time to prevent low-frequency voltages being fed back to the grid circuit.

The table shows suitable values for  $R_1$  and relevant operating conditions for a number of popular 2-volt battery output valves.

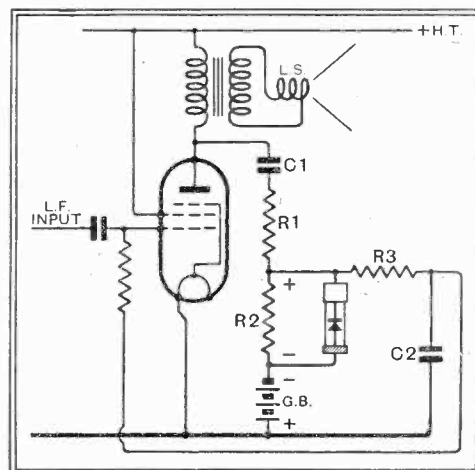

Fig. 1.—Battery economy output circuit using the "Westector" type W6. The value of  $R_1$  depends on the valve and is given in the table,  $R_2$ , 50,000 ohms;  $R_3$ , 250,000 ohms;  $C_1$ , 0.25 mfd.;  $C_2$ , 0.1 mfd.

### R.C.C. or Transformer Coupling

Where it is desired, however, to modify an existing battery receiver for economical working the "Westector" undoubtedly offers a better solution than the addition of a valve, for not only is the conversion cheap in first cost but it does not involve any further expenditure of filament current.

These figures are the result of a series of experiments in the Westinghouse laboratories in which use has been made of the cathode ray tube to detect the commencement of wave-form distortion, and hence the limits between which opposing factors may be varied without prejudicing the resultant performance.

Bearing in mind that no expenditure of H.T. or L.T. current is required by a driver valve, as would be the case in Class "B," and that only three fixed resistances and two by-pass condensers are required in addition to the "Westector," there can be little doubt that this method of applying the principle of battery economy should find wide acceptance among those wishing to modernise their obsolete battery receivers.

Valve.	Battery Volts.	$R_1$ Ohms.	G.B. Volts.	Quies. Current. mA.	Peak Current. mA.	Grid Swing. Volts.	Anode Load. Ohms.	Output mW.
Pen. 220A ..	150	100,000	16½	2.0	20	9	7,500	1,100
Pen. 220A ..	120	100,000	13½	1.3	16	7.5	9,000	700
220 P.T. ..	120	100,000	13½	1.3	16	7.5	9,000	640
Pen. 220 ..	150	150,000	9	1.6	10	4.5	17,000	500
220 H.P.T. ..								
P.T. 2 ..								
P. 220A ..	150	20,000	27.0	2.0	14	14	4,000	300
P. 2 ..								
P. 220 ..								
L.P. 2 ..	150	60,000	13½	0.75	5.5	7	10,000	150
220 P.A. ..								

Values of  $R_1$  and operating conditions for a number of 2-volt output valves.

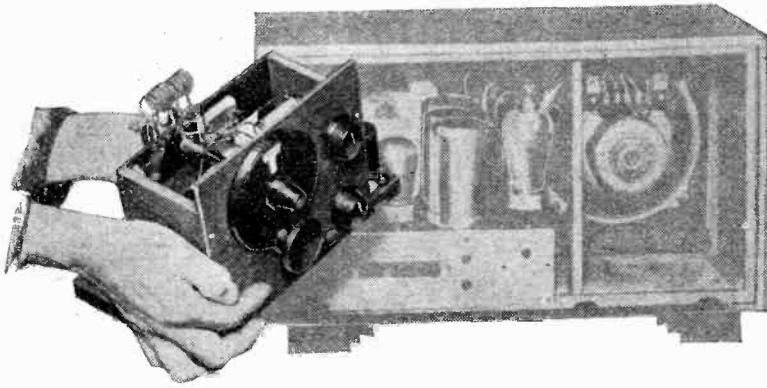

# Ultra Short-Wave Superheterodynes

By W. T. COCKING

## Receiving 5-7 Metre Television Transmissions with Simple Apparatus

RECENT articles in *The Wireless World* have shown that the only hope of high-quality television broadcasting lies in the ultra-short waveband around 5 metres. Comparatively little is yet known about the properties of these wavelengths and about the design of transmitters and receivers for specific purposes. Until recently it was believed that the range of an ultra-short wave transmitter was limited to the optical distance, that is to say, it could be received only at points within the boundary set by the horizon as viewed from the transmitting aerial. It has now been discovered, however, that this range can be greatly exceeded, and the practical limit is usually set at about twice the optical distance. In view of this, it does not seem improbable that with improvements in transmitters and receivers still greater distances may be covered in the future.

The difficulties attendant upon the design and operation of a 5-metre set will be realised when it is remembered that 5 metres represents a frequency of no less than 60,000 kc/s. At such high frequencies tuning coils and condensers assume very modest proportions, and

reception, it is evident that a highly sensitive receiver is called for.

### Advantages of the Superhet

Straight H.F. amplification is barely possible and the detector L.F. set is not sufficiently sensitive, so that the superheterodyne and the super-regenerative set vie for popularity. The latter is extremely useful, and a good example was described recently in the pages of this journal.<sup>1</sup> There are, however, limitations to the maximum sensitivity which can be ob-

*THE ultra-short waveband offers an ideal field for the further development in television, as adequate ether space is available for the higher picture frequencies necessary for good definition. The small superheterodyne adaptor described here provides the means to acquire some experience in the reception of these very short waves*

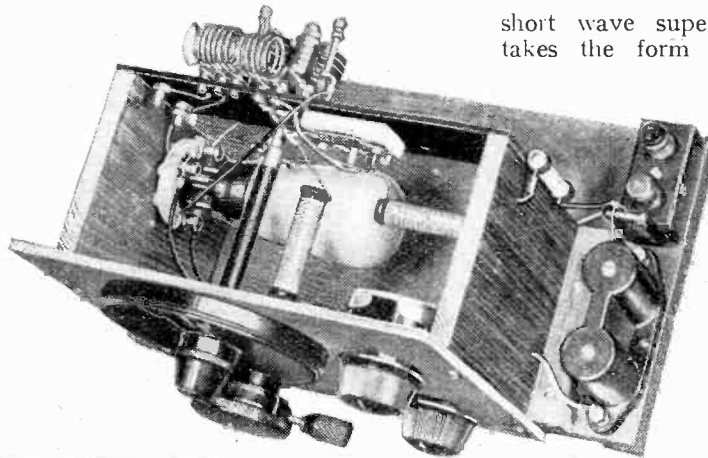

short wave superheterodyne, therefore, takes the form of a battery-operated single-valve autodyne frequency changer for use in conjunction with any standard battery or mains-operated receiver.

Experiment has indicated that the best general reception is obtained with the circuit arrangement shown in Fig. 1. A modified form of Hartley oscillator is used, and it will be

seen that the centre point of the coils is joined through a semi-variable condenser C2 of about 70 mmfd. maximum capacity. The actual tuning capacity, therefore, consists of C2 in series with the variable condenser C1 of 40 mmfd.; in addition, of course, there are the various stray capacities. With the coils employed, about which more later, a tuning range of 5.5 to 7.5 metres is obtained, but this can be varied appreciably by altering the value of C2.

Experience has shown that for satisfactory operation it is necessary for the valve to slide smoothly into oscillation without threshold howl. Even although no such howl may be apparent when the valve is strongly oscillating, the best results are not obtained if the circuit conditions are such that a reduction in the anode voltage leads to howling. With most modern valves a slight positive grid bias is necessary to avoid howling, and a potentiometer R1 is fitted, therefore, to enable the optimum operating point to be readily determined.

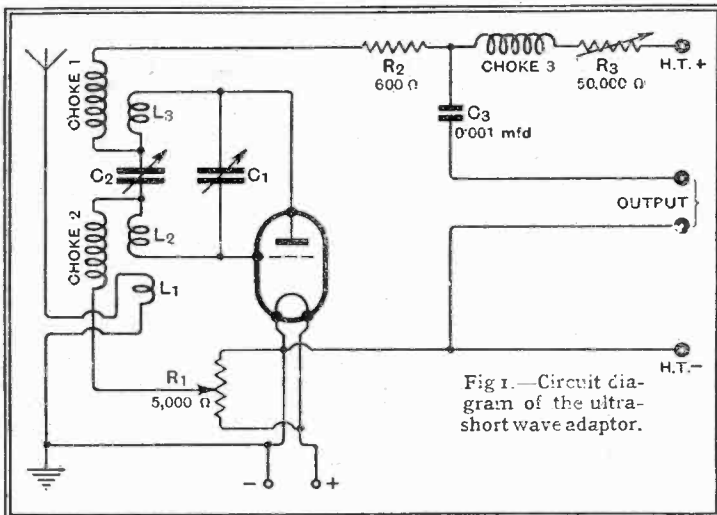

Fig 1.—Circuit diagram of the ultra-short wave adaptor.

stray capacities and even the inductances of connecting leads play an important part. Since transmissions on these high frequencies are rapidly attenuated, and, so far as is known at present, reliance must be placed entirely upon the direct ray for re-

reception, since any ordinary broadcast receiver of three valves or more can be used for the I.F. amplifier, second detector and L.F. circuits. The most practical ultra-

<sup>1</sup> The Ultra Short Wave Two, *The Wireless World*, June 16th, 1933.



**Ultra Short-wave Superheterodynes—**

A variable resistance  $R_3$  is included in the anode circuit to permit a close adjustment of the anode potential. This is not

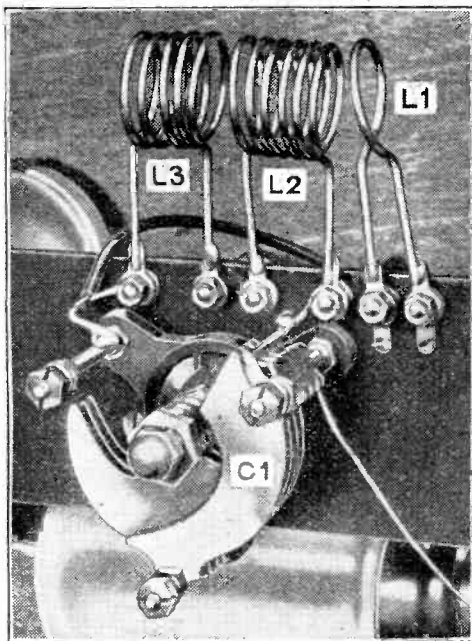

"Close-up" of small sub-panel from which the assembly of the coils and tuning condenser can be clearly seen. The variable resistance just visible to the left of the coils is  $R_3$  and the lettering corresponds with that of Fig. 1.

usually very critical, but the maximum sensitivity is obtained when the valve is only just oscillating. On the other hand, reception of a strong signal necessitates a greater amplitude of oscillation if distortion is to be avoided, and, apart from this, the adjustment of the anode voltage affects the oscillator frequency somewhat, so that the variable resistance can be used as a convenient fine-tuning adjustment. As might be expected, tuning is extremely critical, and a reduction ratio of over 500-1 is necessary. This is readily obtainable with the Igranic Indigraph Micrometer dial, but the closer adjustment obtainable by  $R_3$  is very helpful.

**Constructional Details**

The H.F. chokes  $Ch_1$  and  $Ch_2$  can readily be made by winding about 50 turns of fine wire on a length of  $\frac{3}{8}$  in. tubing to a length of about one inch. Alternatively, the Eddystone type 947 may be used. In order to prevent the valve oscillating at a frequency determined by the chokes instead of the tuning coils, the 600 ohms resistance  $R_2$  is included. The choke  $Ch_3$  for the output feed circuit can be of any good quality type suited to the input of the receiver with which the converter is used.

The tuning coils are very simply made. The grid coil  $L_2$  consists of six turns of No. 16 tinned copper wire, while the anode coil  $L_3$  has five turns; a single turn suffices for the aerial coil  $L_1$ . The coils are close wound on a  $\frac{3}{8}$  in. diameter former. When the tension is slackened the diameter increases somewhat and the former can be removed. The turns of the coil can then be pulled apart so that the spac-

ing of the turns is rather less than the wire diameter. The method of mounting will be clear from the illustrations.

It is essential that the framework holding coils, condensers, and valve should be very rigid, for any vibration will make it impossible to hold a signal. In the layout adopted the valve holder is mounted on the left support, although this does not necessarily give the shortest wiring. It has, however, been found to be convenient where different types of valve are used. With a screen-grid valve, for instance, a very short anode lead can be obtained, and as the greatest sensitivity is obtained with this type, it is obviously the case when most advantage is obtained from short wiring.

In general, the receiver should be tuned to its most sensitive frequency, avoiding any setting upon which interference from broadcasting might occur, the lower end of the long waveband usually being best. The condenser  $C_2$  should be set at about one complete turn from full capacity. The slider of the potentiometer  $R_1$  should be placed at the negative end and  $R_3$  at maximum. Start with a tapping on the H.T. battery, usually about 60 volts, just insufficient to cause oscillation, and then reduce  $R_3$ . If howling occurs when oscillation starts, adjust  $R_1$  to such a point that the valve will just slide into oscillation when  $R_3$  is reduced without any tendency to howl.

**Operating Notes**

With the Mazda HL2 valve employed in the experiments this condition was easily reached with a standing anode current in the oscillating condition of less than 2 mA. A strong signal requires stronger oscillation if distortion is to be avoided, however, and  $R_3$  must then be reduced until the current reads 6 or 8 mA.

Initial testing may offer some difficulties on account of the small number of transmissions on ultra-short wavelengths. It is useful to remember, therefore, that the ignition systems of most cars radiate quite strongly at these high frequencies, and a passing car is usually distinctly audible, and provides a useful, if intermittent, signal for testing purposes.

In cases where the set is to be used in the London area, and is intended chiefly for reception of the experimental transmissions from Crystal Palace and those conducted by the B.B.C., and the E.M.I., a triode oscillator valve is the best. At greater distances, however, a screen-grid valve is to be preferred on account of the higher sensitivity. The circuit remains the same with this type of valve, except for the provision of a screen feed. This should be decoupled by a 5,000 ohms resistance, and a 0.0001  $\mu$ F. by-pass condenser connected between screen and -L.T. A screen potential of 60-80 volts with an anode supply of 100-120 volts is sufficient.

Experiments with this unit have been conducted in the heart of London, and with a three-valve receiver operating a loud speaker. Using a screen-grid frequency changer valve and no aerial the Baird transmissions on 6.25 metres from the Crystal Palace were received at such a strength as to cause an overloading effect in the first valve and serious distortion. It was found necessary, therefore, to change to a triode, for its greater input handling capacity reduced the risk of distortion due to overloading. Television transmissions on a wavelength of about 7.25 metres were also received at a similar strength. At such short ranges an aerial appears to be unnecessary, and this is doubtless accounted for by the large diameter of the coils in relation to the wavelength.

**Available Transmissions**

The unit has been tried with various receivers and with input circuits adjusted to various frequencies between 110 kc/s and 1,500 kc/s with equally good results. Transmissions on these wavelengths are not sufficiently numerous to make 5-metre reception of popular appeal, but it is undoubtedly of great experimental interest. At the present time Baird Television are conducting experimental transmissions from the Crystal Palace on a wavelength of 6.25 metres, and these consist alternately of gramophone records and television. On higher wavelengths both the B.B.C. and the Electrical and Musical Industries are transmitting, and there are numbers of amateurs throughout the country working at various times, so that in most districts

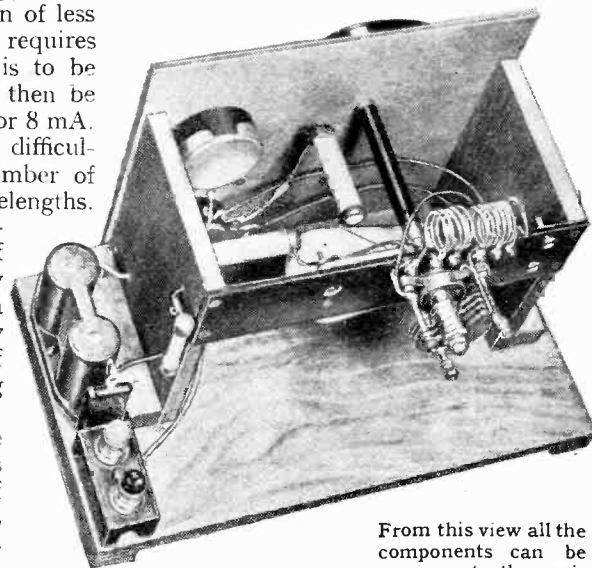

From this view all the components can be seen; note the position of the valve with the two special short-wave H.F. chokes suspended above it.

some station should be easily receivable.

A few remarks about the choice of components may be of interest. The valve-holder should be of the low-loss type and the skeleton model marketed by K.P. Instruments is quite suitable. The semi-variable condenser  $C_2$  should be of rigid construction, and a Cyldon model was used in the original converter with an Eddystone 40 mmfd. microdenser, type Picut, for  $C_1$ .



# NEWS of the WEEK

## Current Events in Brief Review

### For the Critics

FOLLOWING the practice of the B.B.C., the Belgian broadcasting authorities have installed a critics' listening room in Radio House, Brussels.

### More Trouble for Huizen

HUIZEN'S rival, the new 20-kW transmitter at Brasov, Rumania, scheduled to operate on the same wavelength, i.e., 1,875 metres, is, we learn, to start test transmissions on December 1st.

### The Anti-interference War

NEWCASTLE RADIO SOCIETY is seeking permission to send a deputation to the Electricity Board to ask for legislation to be passed prohibiting the supply of electric current to any premises where plant is installed that causes electrical interference to wireless reception.

### Nearing the Sixth Million

THE total number of licences in force at the end of October was 5,768,000, showing a net increase of 47,500 over the figures for the previous month.

### A Silent Show

SILENCE was the rule at the first wireless exhibition at Luxembourg, held from November 12th to the 20th. The Salon was sound-proof and visitors were requested not to converse too loudly so that patrons could judge the quality of the sets being demonstrated.

### "Liquor on the Air"

DESPITE the death of Prohibition, it seems unlikely that American distilleries will be successful in their demands for "time on the air," writes our Wash-

### Wireless on Tap in Holland

HOLLAND now has 613,997 registered listeners, or 74 per thousand of the population. Of this total only 316,956 possess wireless receivers; no fewer than 297,041 subscribe to the wired relay systems.

### A Lucky Listener

A VALUABLE gold watch and Albert chain is to be presented to the 500,000th subscriber to the Austrian broadcasting service. The last reported figure was 495,407, and it is expected that the lucky licensee will put in an appearance within the next few days. The licence figures have jumped considerably since the recent improvements to the Bisamberg station.

### Amateurs and U.S. Navy

IN view of the success achieved with the new Royal Naval Wireless Auxiliary Reserve in this country, it is interesting to note that its "opposite number" in the U.S. was recently addressed by radio from the Washington station by the Secretary of the Navy, the speech being copied by some five hundred radio amateurs all over America.

During the past year the Naval Communication Reservists of the Radio Relay League have taken a very prominent part in emergency working in connection with the California earthquake, the loss of the Akron, the Ohio river flood and recent storms and hurricanes.

### R.S.G.B. Standard Frequency Transmissions

ACCURACY to within 0.01 per cent. is claimed for the new standard frequency transmissions covering the 3.5 kc. band which begin on Sunday next, November 26th, from G6NF, West Norwood, London, S.E. 27, under the auspices of the R.S.G.B. These transmissions, which are to be made on the last Sunday of each calendar month, will adhere to the following schedule:—

09.30 . . . . 3525 kcs (85 metres)  
09.40 . . . . 3625 kcs (82.75 metres)  
09.50 . . . . 3725 kcs (80.6 metres)

The call will consist of R.S.G.B. interspersed with ten-second dashes and statement of frequency. An input of 100 watts to the final amplifier should be adequate to cover the British Isles. Reports of reception will be welcomed by the R.S.G.B.

### International Amateur Broadcasts

THE International DX'ers Alliance announces the following transmissions during the coming week. All times shown are G.M.T.:—

Nov. 26.—8.30-9.30 a.m.	CX26.	Montevideo. 585 kc/s. 512 m.
Nov. 27.—6-7 a.m.	XEPN.	Piedras Negros. 600 kc/s. 500 m.
Nov. 27.—8.30-9.30 a.m.	CP4.	La Paz. 6,080 kc/s. 49.3 m.
Nov. 30.—5.30 a.m.	HIX.	Santa Domingo 579 kc/s. 519 m.
Nov. 30.—5.30 a.m.	HIX.	Santa Domingo. 6,000 kc/s. 50 m.

Reports are welcomed by the I.D.A., 1018, North Prairie Street, Bloomington, Illinois, U.S.A.

### Why Witzleben Broke Down

THE mystery of the breakdown of the Berlin-Witzleben transmitter during the great Hitler speech on November 10th is cleared up by the explanation that the engineers were being too careful. It seems that the engineers feared that the switching off of so many factory lights at the beginning of the speech would mean a disturbance on the power line, so they decided to run the Witzleben transmitter off its reserve Diesel engine. Unhappily, the Diesel engine broke down, and it was necessary to switch over to the mains in the middle of the Chancellor's speech. The interruption to listeners was of less than a minute's duration.

### What Next?

A METZ journal is exhibiting in its windows a wireless receiver contained in a fountain pen. This should be an ideal contrivance for radio critics.

### "O.B." Misses Fire

DURING the recent State Lottery Draw before a huge crowd at the Trocadero, Paris, microphones were present for the broadcasting of the impressions of the lucky ones as their tickets were drawn. Unfortunately, no one present drew a prize.

### Disappointed Teachers

LATEST among those endeavouring to dodge the new French radio tax are the schoolmasters, many of whom have suddenly decided to install "school radio sets" in the hope that these would be exempted from tax. But the law states that receivers are only exempted if permanently installed in class-rooms; many teachers have been using their sets "after hours."

### "Ultra-shorts" in the Air

THE recent ultra-short wave plane tests in this country are recalled by the news that 5-metre transmissions are now being conducted daily from the weather research plane of the Massachusetts Institute of Technology, flying at heights of from 500 feet to nearly four miles above Boston.

The transmissions, which are telephony, give weather information recorded on automatic instruments fastened under the wings of the plane. The American Radio Relay League, which considers the investigation to be the most important of its kind ever attempted, has notified all listeners in the U.S. and Canada to listen and report on reception conditions. During the descents each day special broadcasts for the benefit of amateur operators are made at intervals of 500 feet.

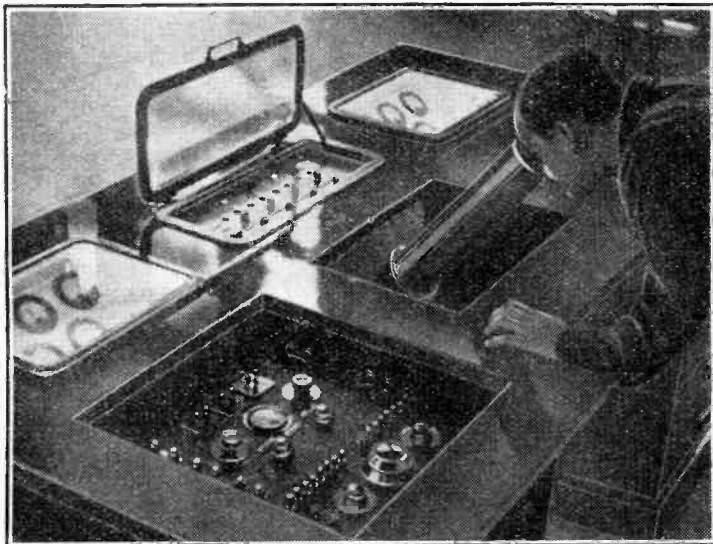

WATCHING THE MODULATION at Lakihegy, near Budapest, where Hungary's new 120-kilowatt is now testing. The engineer is studying the modulation curve in a cathode ray oscilloscope.

### The "No Capacity" Condenser

THE first entirely capacity-free variable condenser was the startling description of a new condenser in the window of a Copenhagen radio dealer, writes our Danish correspondent, and Copenhagen fans agreed that this must be "the real thing" in silent tuning. Actually, the condenser is specially shielded from hand capacity effects.

### Novel Running Commentary

A NOVEL experiment was tried at the recent Copenhagen Traffic Exhibition where visitors gathered before a model of the modern Diesel-engined ferry *Sjælland*, were able to listen to a description by wireless given by an engineer aboard the actual ferry sailing between Korsor and Nyborg. Spectators were able to put questions to the engineer via the short-wave transmitter at Skamlebaek, the answers being reproduced by a loud speaker.

ington correspondent. Already William S. Paley, president of the Columbia broadcasting system, has announced that his network will not carry any advertising of whisky, gin or other "hard liquors," though no reason is seen for refusing to carry programmes sponsored by beer and wine firms.

It is expected that the National Broadcasting Company will either follow suit or await the "shake-down" of the post-prohibition era before deciding what to do.

### Broadcasting from Egypt

ALL private wireless stations in Egypt are to be suppressed with the opening of the new broadcasting station at Abou Zaabal. The Government representatives on the programme committee will include the sub-director of the Police Department, besides Dr. Aly Pacha, Dean of the Faculty of Medicine, and Mohamed Hassanein, Inspector of Educational Establishments. The station is to be worked by the Marconi Company.



# BROADCAST BRIEVITIES

By Our Special Correspondent

## Better Than Loch Ness Monster

NO better breeding ground for rumour can be found than the North of Scotland at the present time, and I believe that even the Loch Ness monster is yielding pride of place to the B.B.C. mobile transmitter, which is said to be making wraith-like appearances on the misty moors, and even in the Firth of Cromarty.

## Island Stronghold?

One old wives' tale has it that the Black Isle, some hundreds of yards from the Cromarty shore, is to be turned into a sort of B.B.C. Heligoland, which Press representatives and others will only be able to visit by boat.

## Nothing Doing?

How true this story may be can be gathered from the reply which I got from the B.B.C. engineering department when asking for confirmation. "Well," said the engineer, "it is an idea, isn't it?"

## Still Searching

No site has yet been chosen, but both Inverness and Culloden Moor seem to be in the running.

Down Newcastle way, too, the engineers are still testing with a mobile transmitter, but no site has yet been found for the North-Eastern Regional.

## 30-line Television to Stay

I AM able to state that a decision has been taken to continue indefinitely the 30-line television transmissions by the Baird Company from Broadcasting House. This disposes of the disturbing rumour that the simpler form of transmission would be entirely supplanted by the high definition tests at the end of March.

It is likely, however, that the time-table of 30-line transmissions will be modified. Possibly, they may be confined to one or two evenings a week.

## An Organ for Athlone?

THE admittedly beautiful tones of the B.B.C. organ seem to have struck a responsive chord in the breasts of other broadcasting organisations, and there is quite a big demand nowadays for new studio organs. Strong pleas are being made for an organ for the Dublin studio, which supplies the programmes broadcast from Athlone. It will be interesting to see whether Ireland can produce an instrument which is a worthy rival of the organ in Portland Place.

## Night Cashier

A NEW little office has been opened in one of those side corridors on the ground floor of Broadcasting House, bearing on the door the romantic sign, "Night Cashier." It is here that the artistes call immediately after completing their performance to receive their cheques.

It is the invariable rule in the B.B.C. that an artiste shall be paid immediately after the broadcast. This rule, as I understand, has never been broken save in the case of a certain famous Scots comedian who believed in C.O.D.

## Prince at Broadcast Cabaret Performance

THE Radio Manufacturers' Association is to be honoured by the presence of His Royal Highness the Prince of Wales on the occasion of the annual banquet at the Savoy Hotel on Monday next, November 27th. A cabaret performance following the banquet is to be heard by London Regional listeners.

## Jack Hylton Again

JACK HYLTON, I am glad to hear, expects to be sufficiently recovered from his illness by December 2nd to be able to appear in the studio with his Boys and give an hour's broadcast for National listeners.

## The People Who Count

FOR a moment I suspected a huge practical joke when running a swift eye over Mr. S. A. Moseley's new "Who's Who in Broadcasting." For the biography of Mr. Rees was followed by that of Dr. J. M. Rendall. There was no REITH!

Then I turned the page and found that the great name was merely in its wrong order. However, Mr. Moseley's own name was in its right order.

## Absentees

Of course, it is easy to criticise a work of this type. Looking for omissions makes a good game for a wet day. I was surprised that no room could be found for such a big figure as G. K. Chesterton, the B.B.C. book critic, and it was disturbing to find no mention of that indefatigable intermediary between the B.B.C. and the Press, Mr. Gladstone Murray.

## Useful Information

However, this "Who's Who" abounds in piquant information. Big Ben is in-

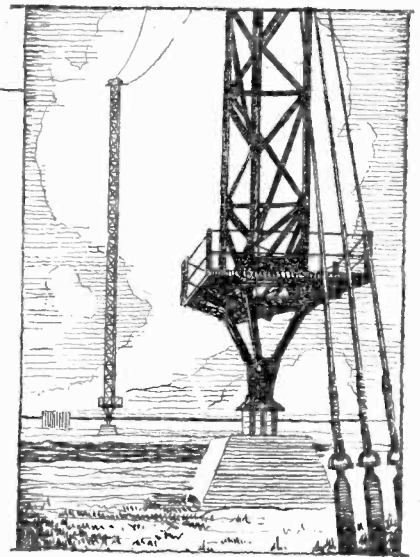

cluded as one of the "personalities," and we are told that Mr. Val Gielgud "believes in Napoleon."

## Where the Money Goes

JUST one farthing of what you and I pay for our wireless licences goes in fees to the B.B.C. Governors. This is one of the exciting facts disclosed in an unusual table printed in the B.B.C. Year Book out today (Friday). For the first time, I believe, the B.B.C. tells the world just how the net amount of 5s. 10d. available to it per licence is distributed among the various activities.

Programmes, including artists' fees, orchestras' news service and programme staff salaries account for 2s. 6½d.

## Engineers Get Elevenpence-Halfpenny

Only 11½d. is consumed by the engineering side, and this covers maintenance of plant, power, research staff salaries, and expenses.

Nasty items like rent, rates, bank interest, etc., use up another 7½d. Replacements of furniture and wireless plant take 4½d., administrative staff salaries 3½d., and the pension fund 1d.

The remaining 11½d. goes as provision for capital expenditure.

## Gramophones and Microphones

Taken as a whole, the Year Book maintains the bright and informative standard of its predecessors. Of special interest, in view of recent controversies, is the article on the application of sound recording to broadcasting.

Wireless World readers would also be interested in the notes on recent microphone developments, particularly in the direction of eliminating resonances.

## Pre-War Vintage

"SCRAPBOOK of 1913," a microphone *mélange* dealing with twenty years ago, has been arranged by Leslie Baily, and will be presented by D. H. Munro in the National programme on December 11th. The pages will be turned by Bransby Williams; but this is no history book, no portentous cavalcade—just a scrapbook of cherished fragments.

## Sun Blinds

IN *The Wireless World* of July 7th last I said that the suggested sun-blinds on the west façade of Broadcasting House would probably be fixed just as the November fogs were beginning. They were putting them up last week.



MID-OCEAN CONTROL ROOM. The microphone and short-wave receiver in the Radio cabin of the s.s. "Jacob Ruppert," which will pick up the weekly broadcasts from the Byrd Antarctic Expedition for relaying over the American Columbia network this winter.



# NEW APPARATUS REVIEWED

## Latest Products of the Manufacturers

### R. & A. "ALPHA" LOUD SPEAKER

THE method which has been adopted in this unit for mounting and centring the diaphragm and speech coil is probably the best that has so far made its appearance in commercial moving coil loud speakers. Instead of being attached to the outer chassis, the periphery of the cone is supported on a separate frame which is accurately located in the centre-pole of the permanent magnet. Thus, the alignment of the speech coil is unaffected by any damage which may be sustained by the outer chassis in its primary capacity of affording protection to the diaphragm. Further, the diaphragm assembly can be removed for the purpose of cleaning the air gap and replaced without any fear of disturbing the alignment.

On test, the unit showed itself to possess an electro-acoustic efficiency which compared very favourably with the mains-energised standard with which it was compared. The overall response has been designed to give a good balance of tone at inputs of the order of 300 to 500 milliwatts, though the unit is well able to handle powers of the order of 5 watts. The range of maximum response is from 70 to 4,500 cycles with a bass resonance at 90 cycles and a region of increased output between 2,500 and 3,500 cycles. Below 70 cycles the output, although considerably less than the general level, is free from frequency doubling, and above 4,500 cycles the response tails off gradually to a cut-off at about 11,000 cycles.

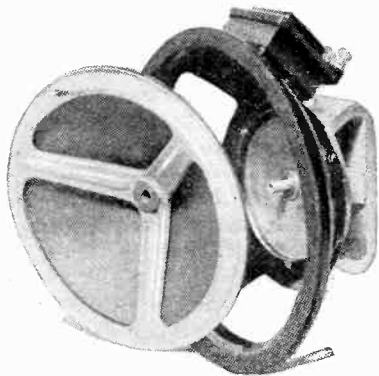

R. & A. "Alpha" loud speaker with diaphragm assembly removed for cleaning the air gap.

Output transformers are supplied for single or push-pull output stages, the former giving six ratios with effective loads from 1,500 to 15,000 ohms. The price is 52s. 6d., and the makers are Reproducers and Amplifiers, Ltd., Frederick Street, Wolverhampton.

### MILLGATE SAFETY FUSE H.T. BATTERY

WHILE an H.T. fuse is often recommended for battery sets it is most unusual to find a safeguard of this nature actually embodied in the battery. Such, however, is the case in the Millgate Safety Fuse H.T. batteries, a 60-volt unit of which we tested recently. The fuse is of the screw-in type rated at 150 mA. and fitted with a standard flash lamp base so that in

an emergency a small lamp could be employed in its place.

The battery measures 9½ in. × 3½ in. × 3 in. overall and is tapped at 12, 18 and thence in six-volt steps up to 60 volts. The fuse is at the negative end.

As it is a standard-capacity model the discharge was commenced at just below 7 mA. through a resistance of fixed value and for intermittent periods, with like intervals for recuperation. On this basis a useful life of 500 working hours was obtained by continuing the discharge until the voltage fell to the equivalent of 0.75 volt per cell or about half the nominal voltage.



Millgate 60-volt battery embodying a safety fuse.

It is of some interest to record that this arbitrary end-point coincided with the natural cut-off of the battery, for, as will be seen from the curve, it did not survive for long after. The voltage is maintained at a most satisfactory level during this period, and in this respect it compares very favourably indeed with the best in its class.

Our tests gave a watt-hour capacity of 95.5 for the battery or 2.3 watt-hour per cell, the battery comprising 41 cells. In view of the long discharge it was not surprising to find the zincs partially disintegrated, yet there was no creeping beyond the limits of the waxed cardboard partitions. It would seem that the battery has given its full measure, and at the price of 5s. 6d. is undoubtedly very good value for money. A 120-volt model of the same capacity is available at 11s.

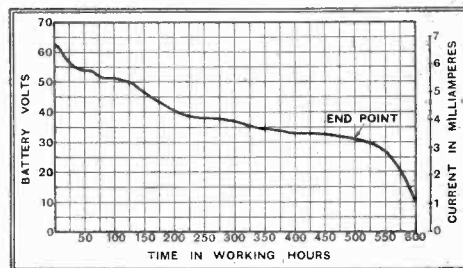

Discharge curve of Millgate Safety Fuse 60-volt H.T. battery.

The makers are Chorlton Metal Co., Ltd., Millgate House, Blossom Street, Manchester, 4.

### CLIMAX S.4 RECEIVER.

IN connection with the review of this receiver in our issue dated November 10th, the makers point out that the price given does not include the pedestal, for which an extra 2 guineas is charged.

### COLUMBIA NO. 22 PICK-UP

IN the latest pick-up designed by the Columbia Graphophone Co., Ltd., 98-108, Clerkenwell Road, London, E.C.1, an interesting innovation has been introduced

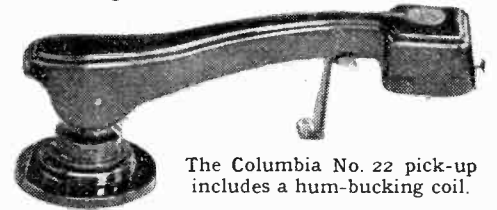

The Columbia No. 22 pick-up includes a hum-bucking coil.

in the form of a hum-bucking coil which is connected in opposition to the pick-up coil and neutralises all hum due to stray fields from the turntable motor.

The pick-up itself has an excellent frequency characteristic, the output in the horizontal middle section being of the order of 0.3 volts R.M.S. The rise in the bass is of the order of 10 db., which is approximately the increase required to correct for recording. The armature resonance at 3,600 cycles is 6 db. on open circuit, but would be reduced when using the recommended volume control of 50,000 ohms.

The moulded tone arm is well designed and lifts vertically for needle changing, a spring-loaded catch being arranged to hold it in this position. The price of the unit is 32s. 6d.

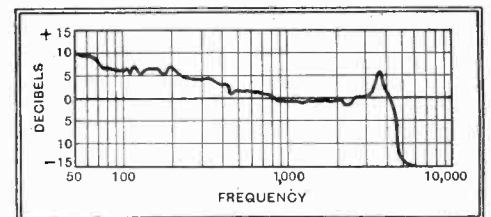

Frequency response of Columbia No. 22 pick-up with Columbia "Talkie" needle.

### CATALOGUES RECEIVED

Varley, 103, Kingsway, London, W.C.2.—Radio components.

General Electric Co., Ltd., Magnet House, Kingsway, London, W.C.2.—Radio receivers.

Baird Television, Ltd., 133, Long Acre, London, W.C.2.—Baird grill cell unit.

Harris and Stern, Ltd., 26, Helmet Row, Old Street, London, E.C.1.—The "Teedback" hacksaw frame.

Lectro Linx, Ltd., 79a, Rochester Row, London, S.W.1.—"Clix" connectors, plugs, sockets, terminals, valve holders, etc.

Pye Radio, Ltd., Africa House, Kingsway, London, W.C.2.—Leaflet describing super-heterodyne receivers.

The Peto-Scott Co., Ltd., 77, City Road, London, E.C.1.—Illustrated catalogue of radio cabinets, including containers for loud speakers and radio-gramophones, and also the new Metalex metal-sprayed baseboards.

Wurlitzer Lyric Radio, Ltd., 33, King Street, Covent Garden, London, W.C.2.—Leaflets describing the Lyric Minor universal midget superheterodyne and the Lyric Cruiser car set.

British Blue Spot Co., Ltd., 94-96, Rosoman Street, Rosebery Avenue, London, E.C.1.—Leaflet describing the Blue Spot Class "B" output stage, complete with loud speaker, for addition to existing receivers.

The Marconiphone Company, Ltd., 210, Tottenham Court Road, London, W.1.—New descriptive folder dealing with Marconiphone receivers and radio-gramophones.



# Television Explained

## V—Mechanical Scanning Systems

**T**HE action of the simplest form of mechanical scanning, the Nipkow disc, has already been dealt with; there are, however, many alternatives which find considerable use in modern television equipment. Undoubtedly, the chief of these is the mirror-drum. The Nipkow disc is replaced at transmitter or receiver, or both, by a

were made the same, the result would be the appearance of a single vertical line of light upon the viewing screen. Each mirror, however, is mounted at a slightly different angle, so that the light reflected from the first causes the light spot to traverse a line at the extreme edge of the screen, the light from the second mirror a line immediately adjacent to this, and so on, until the last mirror gives rise to a line at the other edge of the screen. The whole process is then repeated.

***M**ECCHANICAL scanning methods are not confined to the Nipkow disc, and alternatives such as the mirror drum are often employed successfully. In this article a description is given of the chief systems which are now used or which are interesting from a technical standpoint.*

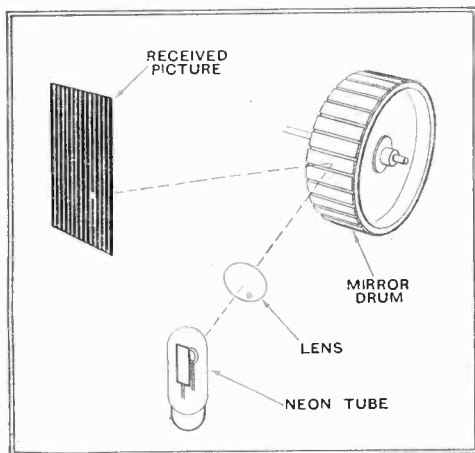

Fig. 1.—Mirror drum apparatus is here depicted diagrammatically. The drum rotates at high speed and each mirror is set at a slightly different angle.

drum the periphery of which carries a series of small mirrors; there is one mirror for every scanning line required, and the mirrors are all identical save for their angle of attachment to the drum.

The arrangement of the receiver is depicted in Fig. 1. The light from the neon tube passes through an optical system for focusing purposes and falls upon one of the mirrors on the drum. It is then reflected on to the viewing screen, and it will be readily appreciated that the precise point on the screen upon which it falls will depend upon the precise angle of the mirror in two planes. The position of the spot on the screen in a horizontal direction depends upon the angle of the mirror relative to the axis of the drum, assuming the neon tube and screen to be correctly placed. The vertical position, however, depends upon the angular displacement of the mirror around the circumference of the drum.

The drum is rotating, so that the spot of light moves across the screen in a vertical direction. If the angle of each mirror

### Vibrating Mirror System

The process achieves the same result as the Nipkow disc, and it has the merit of greater optical efficiency, provided that suitable mirrors are used. There are many variations in practice, and the drum does not necessarily take the form shown in Fig. 1. This is the usual form, certainly, but a modification has been derived in Germany which has the merit of occupying far less space. It is usually known as the mirror screw, and its operation will be seen from the photograph on this page, which is self-explanatory when it is remembered that the screw is rotating about its axis, and that the scanning is carried out horizontally in accordance with the usual practice outside the British Isles.

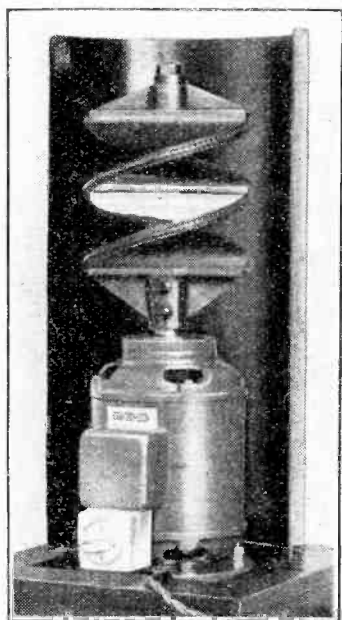

The Tekade mirror-screw employed in Germany.

Other arrangements of mirrors have been tried out, of which the most important is perhaps that employing oscillating mirrors instead of rotating arrangements. This is shown in Fig. 2, and it will be seen that the mirror E oscillates rapidly about its axis AB, while the mirror F oscillates slowly about an axis CD at right angles to that of the former. The beam of light GH from the neon tube falls upon the mirror E, and is reflected from it along the line HI. Now, the angle between GH and HI depends upon the angle between GH and the surface of the mirror, and is just double the latter angle. Since the mirror is oscillating, the angle between GH and HI is continually altering, and the result is to cause the point I where the beam HI impinges upon the surface of the mirror F to move in a vertical direction.

This mirror F, however, is also oscillating about the axis CD, so that the angle between HI and IJ is changing. The

result of the oscillations of both mirrors is to cause the spot of light on the viewing screen to move both vertically and horizontally. The oscillation of mirror E makes the spot move vertically, and that of mirror F gives a horizontal deflection. The oscillation of the former, therefore, is rapid, and gives the scanning lines, while the slowed oscillation of mirror F results in successive lines being correctly displaced sideways.

So far, this system has not proved of great service, for synchronisation of the oscillation frequencies of the mirrors proves far more difficult than in the case of a simple rotating disc or drum. From a theoretical standpoint, however, it is undoubtedly attractive.

### Mechanical Difficulties

With the present 30-lines transmissions mechanical methods of reception can be entirely satisfactory, but it is doubtful whether they can provide the necessary accuracy for the domestic reception of higher grade pictures. Assuming that some form of rotating mirror drum be used, an increase in the number of scanning lines means an increase in the size of the drum. This, in turn, means increased weight, which carries with it the necessity for a more powerful driving motor and greater difficulty of synchronisation. An increase in the number of pictures a second, which is also desirable, means an increase in the

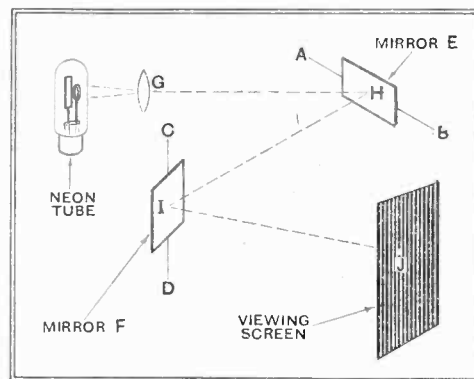
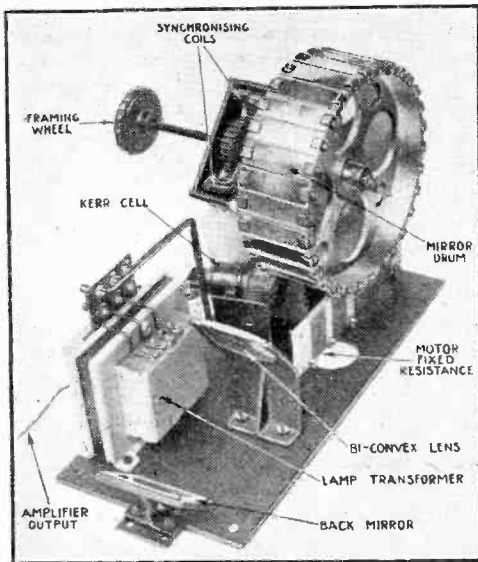

Fig. 2.—A system of scanning involving vibrating mirrors. The action is explained in the text.

**Television Explained—**

speed of rotation of the drum, which introduces further difficulties. It is, of course, quite possible to use a mirror-drum for 120-line transmissions with twenty-five pictures a second, and good quality pictures have been transmitted in this way. Although these pictures could doubtless be received with the aid of a similar drum, its dimensions and the type of motor required to drive it are unlikely to commend themselves for domestic reception, and it is the usual practice, therefore, to abandon mechanical methods for high-quality picture reception, although they may still be employed in transmission. The cathode-ray tube is becoming more and more applied to television reception, and it appears likely to displace mechanical methods entirely.



The arrangement of parts in mirror drum equipment. In this particular case a Kerr cell is used, to modulate a source of light, instead of a neon tube.

Apart from the space required to accommodate the mirror drum and its driving motor, it is a matter of considerable difficulty to obtain completely silent operation, and the whine of the motor can become troublesome. Moreover, cabinet work has to be extremely rigid if the vibration is not to affect the operation. None of these difficulties is apparent with the cathode-ray system, for the arrangement is entirely electrical. The questions involved, therefore, will be considered in some detail in the next article.

**Radio Amateur Call Book**

TRANSMITTERS and short-wave listeners will welcome the autumn edition of this semi-official list of all known amateur transmitting stations of the world. Each succeeding issue is bulkier than the last, and in itself provides good evidence that interest in short-wave working among amateurs is not waning.

It is perhaps a matter for regret that some of the supplementary information has had to be slightly curtailed, but the useful list of Commercial High Frequency Stations is considerably enlarged so that for all practical purposes the book in its growth retains all the particulars likely to be required by its users.

Copies may be obtained in Great Britain from Mr. F. T. Carter, Flat A, Gleneagle Mansions, Streatham, London, S.W.16. Price 6s. 6d. for a single copy, or 21s. for the year.

**DISTANT RECEPTION NOTES****Is Fading on the Decline ?**

A WEEK or two ago I mentioned that owing to the strength at which both Stuttgart and Munich were being received it was difficult to believe that the old low-power transmitter was in use in either case. Both stations still continue to provide first-rate reception. Munich has come in at full loud speaker strength whenever I have tried for it recently, whilst Stuttgart is readily separable—sideband splash excepted—from the London Regional. Were Stuttgart working with an output of only 1.5 kilowatts the selectivity of the set would have to be such that the London Regional was thousands of times "down" only 11 kilocycles off resonance.

Though I have not heard announcements to the effect, I think that the new Tegel station of Berlin Witzleben must be conducting test transmissions on comparatively small power. I have heard Berlin on 419 metres several times during the past week, but not yet at enormous strength.

There is extraordinarily little fading at the moment on the medium waveband, and what there is is of very mild type. With A.V.C. it is completely eliminated, and even without A.V.C. it is seldom bad enough to be at all troublesome.

**Ten-fold Power Increase**

Transatlantic reception is extraordinarily good when conditions are at all favourable. As I predicted some time ago, American stations on wavelengths above 350 metres are now beginning to come in very well. Amongst stations frequently logged during the past few weeks are WGY (379.5 metres), WJZ (394.5 metres), and WLW (428.3 metres).

WLW, by the way, is still transmitting with 50 kilowatts in the aerial, but it will not be long before ten times this power is used in experimental transmissions from the new plant.

On the long waveband Luxembourg is again badly heterodyned and Kalundborg is occasionally affected. Oslo on one recent evening was almost blotted out by continuous-wave morse signals. Huizen is sometimes completely free of the interference that has been troublesome for so long, and when this is the case first-rate reception is assured. Radio-Paris, Zeesen, and Warsaw are all reliable stations, and Motala is generally to be heard.

Some very fine transmissions are to be heard at the top of the medium waveband. Budapest is now in splendid form, whilst Munich, Vienna, Brussels No. 1 and Florence seldom fail to provide full loud speaker volume. Prague is usually very good, but has been varying a little. Langenberg and Lyons Doua are reliable. Beromünster is again heterodyned in the evening, though generally well received in the afternoon. Rome lives up to its reputation as one of the best of European stations and Stockholm is often almost as good.

For some reason Katowice is not so well heard now as it was some weeks ago. Toulouse is invariably a good signal, and Madrid Union Radio is to be heard once more.

Leipzig is strong and reliable. Hamburg varies greatly from night to night, being sometimes excellent and sometimes quite faint. Strasbourg, Brussels No. 2, Milan, Poste Parisien and Breslau are generally

reliable, though Milan and the Poste Parisien are occasionally heterodyned. Brno makes only rare appearances in the log, but when it is received it is always at good strength. Bratislava is badly interfered with, but Hilversum and Heilsberg come through excellently. Turin is generally a good signal and Frankfurt is always worth attention. Trieste, Nürnberg and Fécamp are well heard in the lower part of the medium waveband, whilst both Toulouse PTT and Hörby provide occasional good reception. D. EXER.

**An Interesting Exhibit**

VISITORS to the various Radio Exhibitions which have been held during recent months have been afforded a unique opportunity of examining modern methods of loud speaker construction and assembly in the sectionalised models exhibited by Reproducers and Amplifiers, Ltd., of Wolverhampton. The skill with

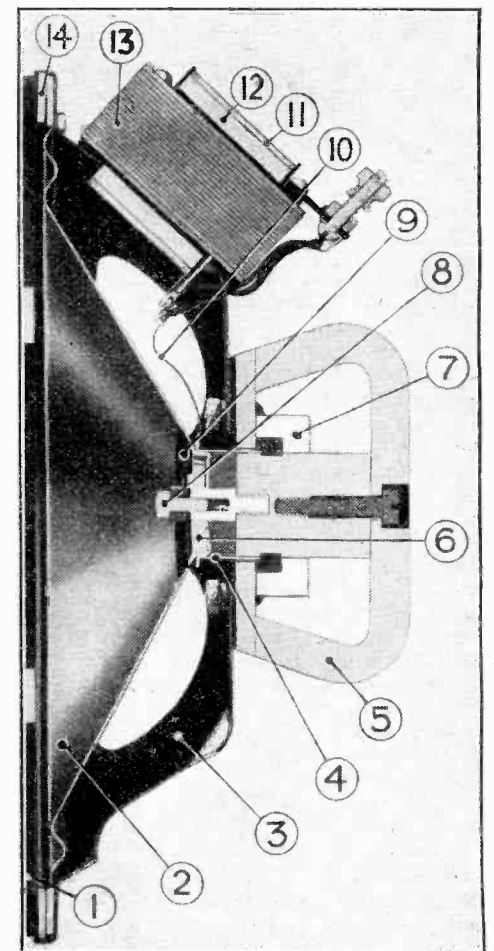

Sectional model of the R. & A. "Challenger" moving-coil loud speaker. The component parts are as follow:—1, baffle felt; 2, diaphragm; 3, chassis; 4, speech coil; 5, magnet; 6, speech coil pressure ring; 7, speech coil dust excluding washer; 8, spider locking screw; 9, centring spider; 10, speech coil lead; 11, transformer secondary winding; 12, transformer primary winding; 13, transformer core; 14, diaphragm clamping section.

which the smallest screws, and even the transformer windings, have been sectioned is a wonderful example of the instrument makers' art, and the function of every component part can be clearly seen.



## Letters to the Editor:—

# Speaker Response Curves

## High Quality: Valves or Stages: Output Control: Disc Records

The Editor does not hold himself responsible for the opinions of his correspondents

### Speaker Response Curves

WHILE no doubt the majority of the readers of *The Wireless World* are familiar with an ordinary curve, I think it should be clearly emphasised that the interpretation of a loud speaker response curve is very different from that of a curve correlating two specific electrical functions.

Whereas the general level and shape of a transformer response curve, for example, gives a visual indication of the true performance of the transformer, the general shape of a speaker response curve is not necessarily an indication of its actual performance, and the curve requires careful interpretation.

Investigation of the response of any loud speaker reveals that the relative difference in output at two very near frequencies is quite appreciable. Actually, if one requires a very accurate indication of the speaker performance it is necessary to plot an exceptionally large number of points, and these points should preferably be plotted at random frequencies where it is noticed that marked deviations in the output arise. If, say, 80 to 100 points are taken, these can then be joined by a substantially curved line, and one obtains a very good approximation of the general nature of the response of a speaker.

When investigating speaker responses in a general manner it is customary to plot only quite a small number of points, perhaps some thirty to forty, and it is then general to join these by a straight line. The resulting "curve" indicates at its various peaks the relative output at the frequencies at which the points were taken. This curve indicates the general nature of the relative response, but obviously it gives no indication of the response on the various straight portions, that is, between the points at which the output has been measured.

Both types of curve are in general use, and they each serve their specific purpose, and accordingly it seems to me very desirable that the lay reader should appreciate the significance of each type so that he may draw his own conclusions when studying a response curve.

It should also be realised that response curves are taken by measuring the output of a capacity microphone when the speaker is energised by a sine wave. Should, however, the speaker introduce frequency doubling or other wave form distortion no indication of this is given by the curve, which is obtained by plotting the amplified microphone voltage, which in many cases is of unknown wave form. The actual performance of a speaker can, therefore, only be obtained by simultaneous oscillograph examination, or, alternatively, some electrical system of wave form distortion or harmonic analysis.

Finally, it must be remembered that these measurements are made under static conditions and the curve given by a microphone output is no criterion of the ability of a speaker to deal with transients which have such a marked bearing upon the all-import-

ant question of attack. Accordingly, the speaker response curve to my mind should be regarded only as a "pointer" rather than a graphic delineation of electrical and acoustic constants.

Watford.

PAUL D. TYERS.

### "Mystery" Station

WITH reference to the controversy with regard to the "Mystery" station causing so much trouble with Huizen transmissions, may I respectfully state that this is most definitely not a Rumanian station?

After Huizen has closed down, I have, on many occasions, picked up the interfering station, which, at all times, has been radiating a sort of inter-station discussion in Russian, in common with other Soviet transmitters. There is no Rumanian station using Russian, and this is definitely a Soviet station.

LEOPOLD FRIEDMAN.

Edgware, Middlesex.

### High Quality

A HIGH quality receiver should respond similarly to the modulation of signals of all wavelengths in a given waveband.

The *Wireless World* Autotone (which was described in theory and in practical form in issues published at the end of 1931 and beginning of 1932) is the only receiver that theoretically fulfils this condition.

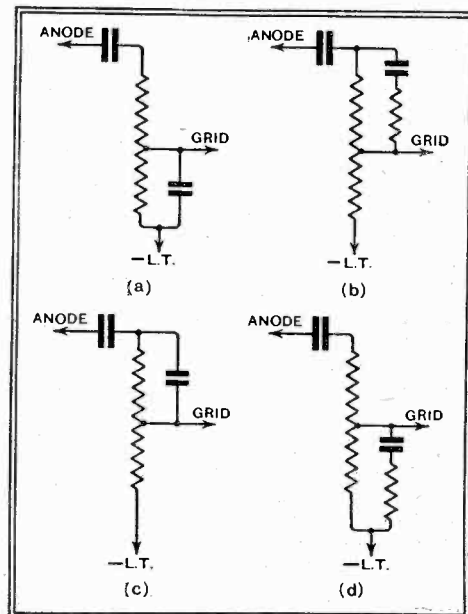

(a) To reduce treble; (b) to reduce bass; (c) to increase treble; (d) to increase bass.

To preserve transients, transformers and any inductive L.F. coupling must be avoided. This means that a sharp cut-off in the L.F. circuits to remove heterodynes

Correspondence, which should be as brief as possible, should be addressed to the Editor, "The Wireless World," Dorset House, Stamford Street, S.E.1, and must be accompanied by the writer's name and address

is not possible. However, a large degree of tone correction can be obtained with R.C. couplings in suitable combinations as shown in the figure.

To obtain a sharp cut-off at the top of the spectrum, I suggest arranging for a peak separation in two I.F. transformers of 10 kc/s or more according to conditions and requirements. Further, I suggest using a valve to provide reaction on the single H.F. circuit to provide the necessary selectivity.

By means of mechanical arrangements similar to those used in the Autotone, the H.F. resistance of this signal tuned circuit can be kept constant at a low value throughout the waveband, though, of course, not so low as in the Autotone. By this means a straight line L.F. response can be obtained throughout the waveband.

F. L. INGRAM.

Kingston-on-Thames.

### Output

I HAVE just read with interest the letter by "Lead-in" on output. On reading the last sentence, stating that the example is a strong argument for the use of a double output stage when separate high- and low-note speakers are used, I am led to believe that the writer himself does not see where the "obvious" fallacy lies.

When 25 volts peak of f1 and 25 volts peak of f2 are together applied to the grids loading them with 50 volts peak the output will be 8 watts, and not 4 watts, as stated. For this reason "Lead-in" has not made me decide to fit a double output stage to feed my speakers, which are of the type mentioned.

H. GRAYSON.

Manchester.

### Valves or Stages?

WHILE the system of describing a wireless receiver by its number of stages is perhaps better than the number of valves system, it is by no means ideal, for as pointed out in the letter from Mr. G. A. Taylor in your issue of September 30th, an A.V.C. diode can be counted as a stage without improving the receiver from the point of view of range.

The layman buying a receiver wants an indication of the volume of sound a receiver will produce when operating on a given station, or, alternatively, an indication of the number of stations that can be received at a given volume. Hitherto with a straight battery-driven set the number of valves could be taken as a rough guide, but with modern developments such a procedure is liable to be misleading.

The ideal method would be to describe a receiver by its overall amplification. Since the actual amplification obtained will depend on the efficiency of the circuits in addition to the valves the actual amplification could not be readily checked, and misrepresentation would be possible. To avoid this the figure obtained by multiplying together the amplification factors of all the valves which contribute to the over-



all magnification of the set could be used. This figure could be easily checked from the valve makers' catalogues. Since this figure would run into millions a unit consisting of a million magnifications could be devised.

This system would be similar to the horsepower method of rating cars.

Plumstead. W. HARMER.

THE letter from R. J. Cotterswood in your issue for October 27th seems to deal very thoroughly with the question of how receivers shall be designated, and, whilst his suggestions would probably be ideal and indicate pretty clearly the performance of receivers, it is unfortunate that, speaking from the general commercial point of view, the ladies are mainly responsible for choice of wireless sets, and their choice is very largely in the direction of pretty-pretty cabinets, to the exclusion of what may be inside, and, until such time, if ever, that they develop a real interest and intelligence as to what is inside, the question of a precise specification is not of much importance, although, as I explained in my original letter, I consider this should always be included in the technical details of the set, which should be as full as possible, but which are really understood by a very tiny minority.

of the electron stream, a thing which, in these days of bigger and better electrons, should be unheard of. J. BAGGS  
Manchester.

### Output Control

THE complaint regarding the annoying activities of the B.B.C. output control engineers during organ broadcasts appears in your Correspondence columns at an opportune moment. Whatever reasons might be advanced in favour of exercising this control in the case of "outside" broadcasts, it is difficult to understand how it can be justified in connection with the B.B.C.'s own organ. This instrument exists solely for broadcasting purposes, and was designed in every detail with this end in view.

On September 10th, during a broadcast intended to demonstrate the various features of this organ, the softest stop and the full power of the instrument were shown in contrast—at least, this is what was intended. The desired effect was, however, frustrated by the control engineer, who, having increased the power of the softest stop so that the listener had no idea of its relative softness, had to "cut down" the volume of the full organ to a much lower level—a fraction of a second too late, however.

This kind of thing naturally is most an-

must be negligible compared with the cost of pressing records.

(3) Is it not a fact that the day of the cheap acoustic gramophone has now passed for ever, especially having regard to the comparatively cheap and efficient electrical reproducer?

(4) Why should Flight-Lieut. King, or, indeed, anyone else, go to the expense of purchasing a two turntable unit when a better reproducer could be made commercially by the use of "film"?

(5) I agree that the Gramophone Company have done very much indeed in furthering the cause of good music, but will the Company give unequivocal answers to Flight-Lieut. King's questions, viz.:—

(a) Why have not the gramophone companies produced an instrument on the lines suggested?

And

(b) Are the gramophone companies afraid that they are going to lose money on scrapping the existing equipment?

I think the answers would be interesting  
London, S.E.23. J. L. CARDEN.

## CLUB NEWS

### D.F. at Sea

Actual experiences of direction finding at sea were related by Mr. Rapsey in his lecture on direction and position finding by the Bellini-Tosi system, at a meeting of the Southall Radio Society. Hon. Secretary: Mr. A. J. Stephens, 98, Pole Hill Road, Hillingdon.

### Straight Set Wins

Two to one in favour of the straight set was the outcome of the voting after a hard-hitting debate on "Superhet v. Straight Set" at a recent meeting of Slade Radio (Birmingham). The annual general meeting is to be held on November 30th, 8 p.m., at the Parochial Hall, Broomfield Road, Erdington. Hon. Secretary: 110, Hillaries Road, Gravelly Hill, Birmingham.

### Improving Quality

A demonstration of "Correcting Bass Response in Gramophone Reproduction" will be given by Mr. A. H. Pratt at the meeting of the Exeter and District Wireless Society, at 8 p.m., on Monday next, November 27th. Hon. Secretary: Mr. W. J. Ching, 9, Sivell Place, Heavitree.

### The Acid Test

Fourteen loud speakers were put on trial at this season's first joint meeting of the Croydon and Thornton Heath Radio Societies. A home-made valve oscillator giving frequencies between approximately 75 to 6,000 cycles was used to discover bad resonances. On Tuesday next, November 28th, the Croydon Society will hold its short-wave night. Hon. Secretary: Mr. E. L. Cumbers, 14, Campden Road, South Croydon.

### Demonstrating Exponential Horns

"Exponential Horn Loud Speakers and Quality" is the title of a lecture to be given by Mr. E. Mewse, M.Sc., at the meeting on Monday next, November 27th, of the Newcastle-upon-Tyne Radio Society, in the Church Hall, Armstrong Bridge, Jesmond. Hon. Secretary: Mr. W. W. Pope, 9, Kimberley Gardens, Jesmond.

### Bargains!

The Edinburgh and District Radio Society will hold an auction sale on Thursday next, November 30th. Full particulars are obtainable from the Hon. Secretary, Mr. W. Winkler, 13, Lockharton Crescent, Edinburgh.

### Ratepayers' Radio

The theory of the detector valve and of transformers will be dealt with by the New Eltham Ratepayers' Association, Radio Section, on November 30th. Meetings are held on alternate Thursdays at 8 p.m., at the Bungalow in the grounds of The Beehive Hotel, Footscray Road, Eltham. Hon. Secretary: Mr. A. E. Gillborn, 87, Montbelle Road, New Eltham, S.E.9.

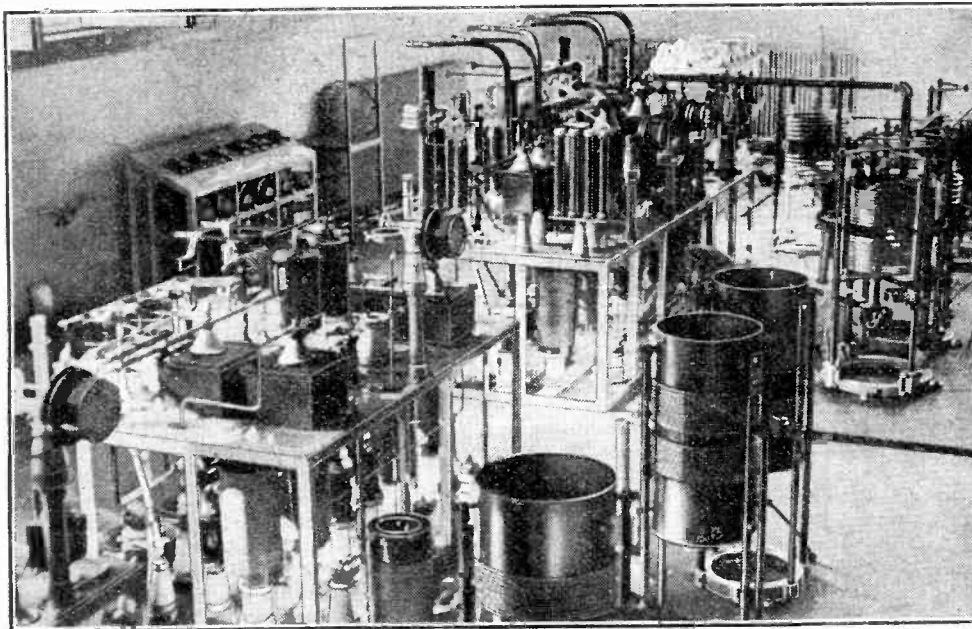

GERMANY'S LATEST. The new 100 kW. station or "Grossrundfunksender" at Tegel near Berlin, is already testing. Above is a view of the output stages of the transmitter.

My main objection to the specification of stages was the difficulty in being quite clear as to the definition of a stage, since, for example, in a superheterodyne receiver if the oscillator portion consists of a stage it is just as logical for the A.C. rectifier to be included as a stage as well, or possibly the oscillator and first detector might be combined as one stage, in which case, of course, they line up with the valve position in those sets which employ a combined oscillator-modulator, such as the Heptode.

On the other hand, the number of valves in a set is a thing that can readily be seen, whereas the specification of stages leaves the matter open to endless wangling, which is, perhaps, more common to the radio industry than any other.

In conclusion, I should like to apologise most humbly to "Free Grid," and also to your aforementioned correspondent, for having inadvertently reversed the direction

noying to listeners, and it is time something was done to check such unwarrantable interference with the effects aimed at by broadcast performers.

VERNON C. COOMBS.

Bromley, Kent.

### Alternatives to the Disc Record

I HAVE followed this correspondence with great interest, and I am surprised at the very unsatisfactory reply of the Gramophone Company, Ltd., to Flight-Lieut. Patrick King's letter.

To take the points in the order:—

(1) I fear that the Gramophone Company has not read *The Wireless World* very carefully, otherwise such an article as "Synthetic Sound"—issue of February 3rd, 1933—would undoubtedly have given a very broad hint. Upon what scientific grounds is a paper "film" impracticable?

(2) The cost of printing paper "films"



# The Faraday All-wave Superheterodyne <sup>S.</sup> 620L

## Incorporating A.V.C.

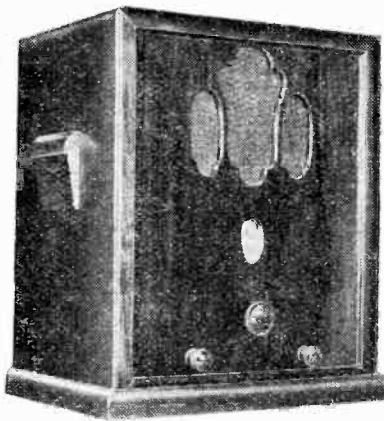

**FEATURES.** *Type.*—Table model superheterodyne receiver for A.C. mains, covering wavelengths from 15-2,000 metres. *Includes automatic volume control and a moving-coil loud speaker.* **Circuit.**—Var.-mu H.F. pentode signal frequency amplifier—H.F. pentode frequency changer—var.-mu H.F. pentode I.F. stage—duo-diode pentode second detector—pentode output valve. **Controls.**—(1) Tuning calibration on all four wave-ranges. (2) Wave-range switch. (3) Volume and on-off switch. (4) Tone control switch. **Price.**—In walnut cabinet, £28 10s. **Makers.**—Faraday All-wave Wireless, 1, Salvott Road, London, S.W.11.

from Bound Brook was sufficient to actuate the automatic volume control, so that the background noise was reduced to a negligible level except during one or two intervals of severe fading. The manual volume control could not be increased to beyond the mid-position without overloading.

Although tuning is of necessity sharp on the short-wave stations, the stability of the circuit, even on an indifferent earth system, is above criticism, while accurate calibration on the short wavelengths is a feature which is all too rare in sets of this type.

Having successfully solved the problems presented by the short wavelengths, it is only to be expected that the designers would provide a good medium and long wave performance. Twenty-three stations

**E**XTERNALLY the chassis is very little different in appearance from last year's model, which was reviewed in our issue dated October 28th, 1932, but several alterations have been made in the circuit which have resulted in improved performance.

Full advantage has been taken of the latest types of valves, and a duo-diode pentode has been employed in the second detector stage to give automatic volume control, which is of the greatest possible value when receiving short-wave stations which are subject to fading. Variable-mu H.F. pentodes are used in the H.F. and I.F. stages, which are both controlled on the medium- and long-wave bands. On short waves the signal frequency H.F. stage is running at full magnification, and the control is confined to the I.F. amplifier.

The frequency changer circuit is interesting. The valve used is an ordinary H.F. pentode, and the cathode, working grid and screen grid are used as the three electrodes of a modified Hartley oscillator. The anode is given a slightly higher potential than the screen grid, and the coupling to the I.F. circuit is made *via* the electron stream from screen grid to anode. This gives a very stable and efficient circuit, which is admirably suited to short-wave conditions.

On medium and long waves the anode circuit of the signal frequency amplifier stage is tuned to the incoming signal, the coupling to the oscillator circuit being effected by resistances common to both circuits. On short waves, however, the anode is connected directly to the oscillator circuit. An aerial trimmer is provided, and the necessary adjustment is facilitated by connecting a voltmeter across the resistance providing the minimum bias for the variable-mu H.F. and I.F. valves. The second detector and A.V.C. circuits follow accepted practice,

and a measure of tone control is introduced at this point by switching a small fixed condenser across the load resistance.

The performance on short waves naturally received first attention, and it is safe to say that the sensitivity and overall mag-

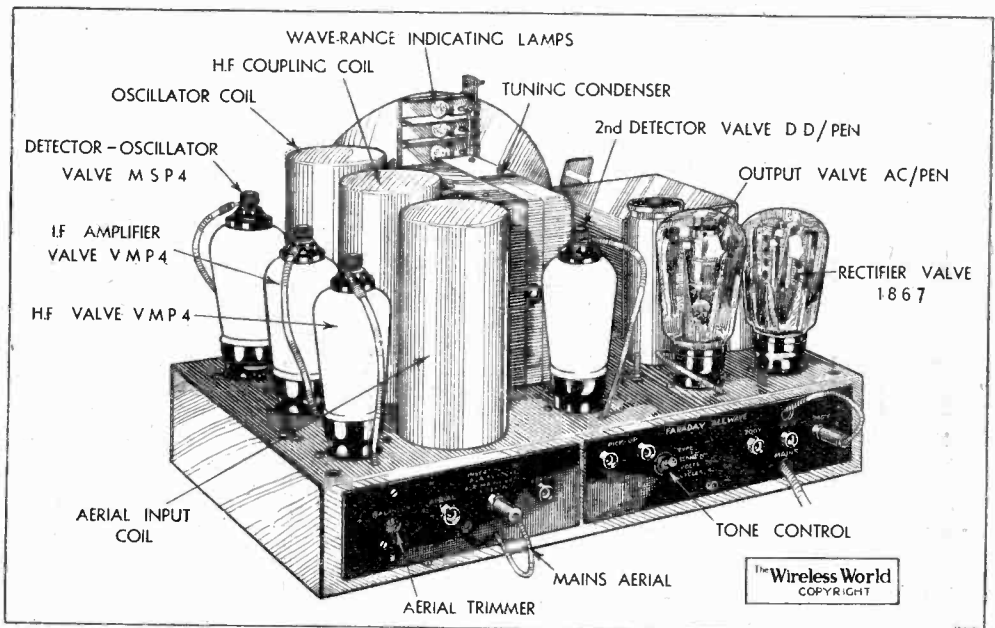

Although radical changes have been made in the design of the circuit, the appearance of the chassis differs little from last year's model.

nification would impress the most experienced short-wave enthusiast. At the time of our tests the 15-30 metre band gave best results, and Pittsburgh, W8XXK, and Bound Brook, W3XAL, were well received in daylight during the afternoon. Although the receiver was installed in Central London near a busy thoroughfare and a certain amount of interference from car ignition systems was experienced, the signal strength

were, in fact, logged on the medium wave-band in daylight, and the selectivity was sufficient to give adjacent channel separation on all stations with the exception of the local transmitters, where one channel on either side was lost.

A very full instruction booklet, containing useful information on short-wave conditions in general, and a wiring blue print is issued with each set.

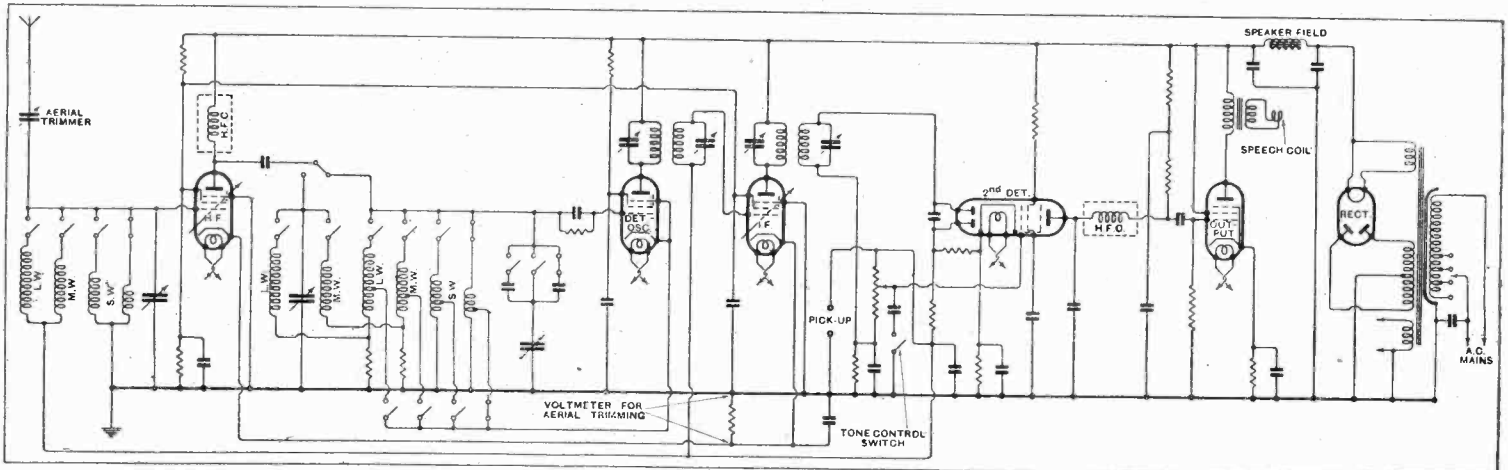

Complete circuit diagram. An H.F. pentode frequency changer and a duo-diode pentode second detector are features of the circuit in its latest form.

# READERS' PROBLEMS

## Grid Return Leads

THE fitting of A.V.C. to existing receivers (especially to those of the super-heterodyne type) becomes easier and easier, but it would seem that many constructors are still uncertain as to the precise nature of the slight alteration that must be made in the grid circuit of the controlled valve (or valves).

These difficulties will generally disappear if it is realised clearly what we have to do. Put as simply and briefly as possible, the grid return leads of the controlled valves must be disconnected from the original source of fixed or manually-regulated bias, and then reconnected to the source of A.V.C. voltage in order that the operating bias may be varied automatically in sympathy with the strength of incoming carrier waves. In addition, decoupling will generally be needed.

With regard to the simplest type of mains-

THESE columns are reserved for the publication of matter of general interest arising out of problems submitted by our readers. Readers requiring an individual reply to their technical questions by post are referred to "The Wireless World" Information Bureau, of which brief particulars, with the fee charged, are to be found at the foot of this page.

factory, it seems very likely that it is responsible for poor quality. It should be emphasised that the design of such transformers is by no means a simple matter, and that satisfactory specimens are only produced by firms who have devoted a good deal of thought to the subject.

## Keep it Carefully

A CORRESPONDENT is using an eliminator rated to give 30 milliamps. at 150 volts. The H.F. and detector valves of his receiver consume between them 10 milliamps., leaving 20 milliamps. for the output valve.

What we are asked to do is to suggest a suitable 3 - electrode battery-operated output valve which will absorb the available 20 milliamps.

We sincerely hope that our correspondent has not already mislaid the Valve Data Booklet included in our issue of November 3rd! A glance at that invaluable little publication will show that almost every manufacturer produces a 2-volt valve requiring between 18 and 20 milliamps.; there are so many excellent specimens that we can hardly draw invidious comparisons.

## Where Losses are Unimportant

A QUERIST, who is not completely satisfied with the sensitivity of his newly built receiver, asks whether it is possible that efficiency could be improved by replacing the present reaction condenser, which has bakelite dielectric between the vanes, by one of the air-dielectric type.

As compared with air, it is certain that

.....

## The Wireless World INFORMATION BUREAU

THE service is intended primarily for readers meeting with difficulties in the construction, adjustment, operation, or maintenance of wireless receivers described in *The Wireless World*, or those of commercial design which from time to time are reviewed in the pages of *The Wireless World*. Every endeavour will be made to deal with queries on all wireless matters, provided that they are of such a nature that they can be dealt with satisfactorily in a letter.

Communications should be addressed to *The Wireless World* Information Bureau, Dorset House, Stamford Street, London, S.E.1, and must be accompanied by a remittance of 5s. to cover the cost of the service. The enquirer's name and address should be written in block letters at the top of all communications.

any solid dielectric material in common use is bound to introduce considerably higher losses. But in a reaction circuit it is most unlikely that these losses will have any prejudicial effect on sensitivity or selectivity. It is therefore suggested that, if self-oscillation can be brought about at all wavelengths, it is hardly worth while to make a change. Probably some other part of the receiver is susceptible to improvement.

## Diode Potentiometer

IT is worth while pointing out that, with diode detection, there is no better method of obtaining post-detection volume control than by using a potentiometer (in place of a plain resistance) as the diode output load. Any desired proportion of the rectified voltage developed across this load may then be applied to the succeeding L.F. amplifier in the simplest possible manner, and without risk of introducing distortion.

These remarks are prompted by letters from two or three readers who have proposed unnecessarily complicated—and sometimes rather ineffective—methods of L.F. volume control in sets where diode rectification is employed. The same applies to receivers employing a Westector, which is in many ways comparable with a diode valve.

## High-output Battery Amplifier

ALTHOUGH the undistorted output obtainable from the Class "B" system is enormous when judged by previous standards set for battery valves, it still falls short of that required in many instances for public address work. But by the use of two of the new valves in parallel it should be possible to obtain sufficient volume for many purposes without overtaxing the capabilities of a good high-capacity dry battery.

This subject is raised by a reader who asks for information on the "paralleling" of Class "B" valves. It seems probable that, even with a specially designed driver transformer, it would be extremely risky to connect merely the output valves in parallel in the obvious manner; apart from other difficulties, parasitic oscillation would probably occur. It is therefore recommended that both the driver and output valves

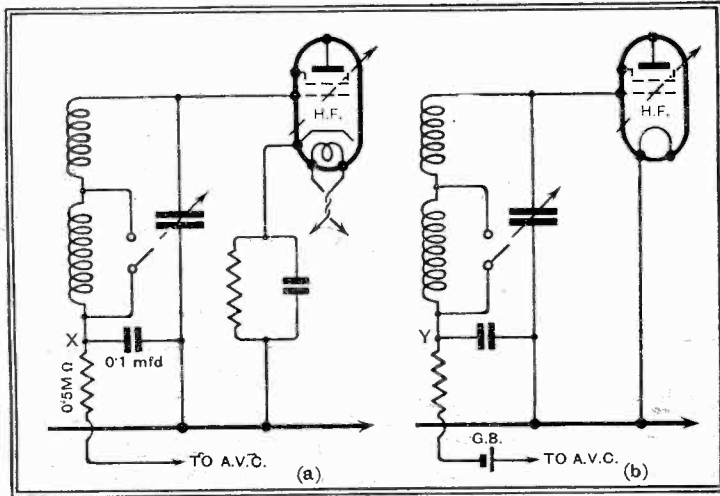

Fig. 1. When A.V.C. is added, slight alterations in the grid return circuits of "controlled" valves are usually needed.

operated set, all that will have to be done in the way of disconnection is to take off the lead joining the low-potential end of the grid coil from the earth line or metal chassis. This point, which is marked X in Fig. 1 (a), is now joined to the source of A.V.C. voltage through a decoupling resistance, the associated by-pass condenser being added to "tie down" the circuit so far as H.F. impulses are concerned.

In battery sets (Fig. 1 (b)) the procedure is basically the same. The low-potential end of the grid coil (marked Y in this diagram) was probably joined originally to earth through a bias cell, which should now be disconnected and then replaced on the other side of the decoupling resistance as shown.

## Class "B" Pitfalls

IT has been proved that a properly designed Class "B" amplifier is capable of giving very pleasing quality; a good deal of space has lately been devoted in these pages to the eradication of the minor difficulties that are likely to prevent the attainment of good results.

A querist who has tried all the usual cures for distortion, but without success, now solicits our help: his circuit arrangement is correct, but he is using a driver transformer of unknown make.

Although this component may be satis-

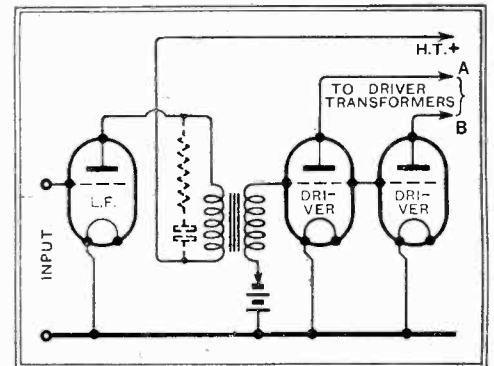

Fig. 2.—Duplicated Class "B" amplifier with exceptional power output. From points A and B onwards the separate output valve circuits are independent.

should be duplicated; thus, two driver valves, two driver transformers, and two output valves, each feeding separate speakers, will be needed. The drivers will be connected as in Fig. 2, with their grids joined together. As the driver valve is a purely voltage-operated device and consumes no power, several may be "paralleled."